

VOLVO SEDANS



Character. Grounded in substance not rhetoric, character is earned not claimed. As with people, so too with automobiles, character reveals itself, slowly, over time through a demonstrated commitment to a defining set of ideals.

Gustaf Larson and Assar Gabrielsson founded Volvo on the core values of quality, durability and reliability. The harsh Scandinavian environment demanded it. Our Volvos delivered it.

Our 544 sedan introduced Volvo's core values and concern for safety to America in 1956. By 1959, the 122 sedan was challenging America to -"Drive it like you hate it."

The 140, new for 1968, advanced automobile safety as a core value promoting occupant protection as a science and design objective. Our innovative 140 and 240 would serve as templates for automotive safety design in years to come. Today, the core values that inspired the first Volvo and the proud Volvo heritage of meaningful innovation are in evidence throughout the Volvo line of 240, 940 and 960 family sedans.







Substance defines value. An abundance of substance defines true luxury. To experience true luxury, take the wheel of the Volvo 960. As the flagship of the Volvo family, it defines luxury through the thoughtful execution of sophisticated technology and a meticulous attention to detail.

On the road, our 960 delivers a combination of comfort and spirited performance that defines a unique class of luxury car - the grand touring sedan.

State-of-the-art engineering affords the 960 driver total command of a formidable European road car. The 24-valve, 201 hp, all alloy, in-line six eagerly responds to the demands of the road, and the mood of the driver, through the four-speed electronic automatic transmission featuring sport, economy and winter driving mode selection.

We believe the best time to assess a vehicle's level of luxury is not when you get in, but when you get out. After hours on the road, Volvo 960 occupants emerge from the 960's interior cabin undiminished by the journey.

960



Rich leather surfaces and the legendary comfort of Volvo seat design await as you enter the Volvo 960.

Painstakingly engineered with thoughtful attention to ergonomic detail and creature comforts, the 960 interior distinguishes this Volvo as both a luxury sedan and a true driver's car.

All gauges, instruments and controls are positioned to be natural extensions of your body. The adjustable steering column, power seats, automatic climate control, premium sound system with large format controls, sunroof and myriad amenities all contribute to a driving environment of extraordinary comfort, quiet and well being.

Air bags and automatic seatbelt pretensioners for both driver and front passenger supplement the advanced safety engineering designed to help protect occupants. All five seating positions enjoy the security of a three-point seat belt and padded head restraint.









Scrubbed clean of the grime accrued in meeting the many demands of family service, the 940 stands ready. Whether for confident transport of the kids to school, or an elegant evening out, the 940 is ideally suited. Engineered and built with care and precision, the Volvo 940 will reinforce the wisdom of the buying decision for years to come.

While the 940 conveys the reassuring confidence inherent in a large vehicle, it is none-the-less remarkably maneuverable and fuel efficient.

Whether taking a quick trip to the store or embarking on a long vacation trek, your 940 is a most accommodating companion eager to make your journey a pleasant one.

Creature comforts that make the miles seem shorter abound. Heated orthopedically designed seats, air conditioning, cruise control, power driver's seat with three memory positions and a six-speaker sound system enhance the overall level of driving pleasure.

For those wishing to enjoy even more in their 940, the 940 luxury option package offers alloy wheels, power sunroof, leather upholstery and a premium full logic, AM/FM stereo cassette.

940

Light stanchions flick by as the sweeping curve of the entrance ramp straightens to feed into the blurred traffic of the interstate. This is when you want power to spare. The Volvo 940 Turbo delivers.

Distinguished by the signature Turbo "egg crate" grille, the 940 Turbo responds with dramatic and immediate acceleration on demand. Steady and strong, like the heartbeat of an Olympian, Volvo's turbocharged, intercooled engine powers the Turbo effortlessly through its broad power range.

Integral fog lights and high speed rated

195/65R15 tires on alloy wheels enhance the Turbo option package.

Athletic, yes, but without sacrificing any of the large car ambiance and comfort of the Volvo 940 series. The Turbo option package features orthopedically designed seating with leather upholstery, ergonomically refined instrumentation, air conditioning, power sunroof and 6-speaker premium audio system with full-logic cassette to create an environment of exceptional luxury in the Turbo's roomy interior.





940

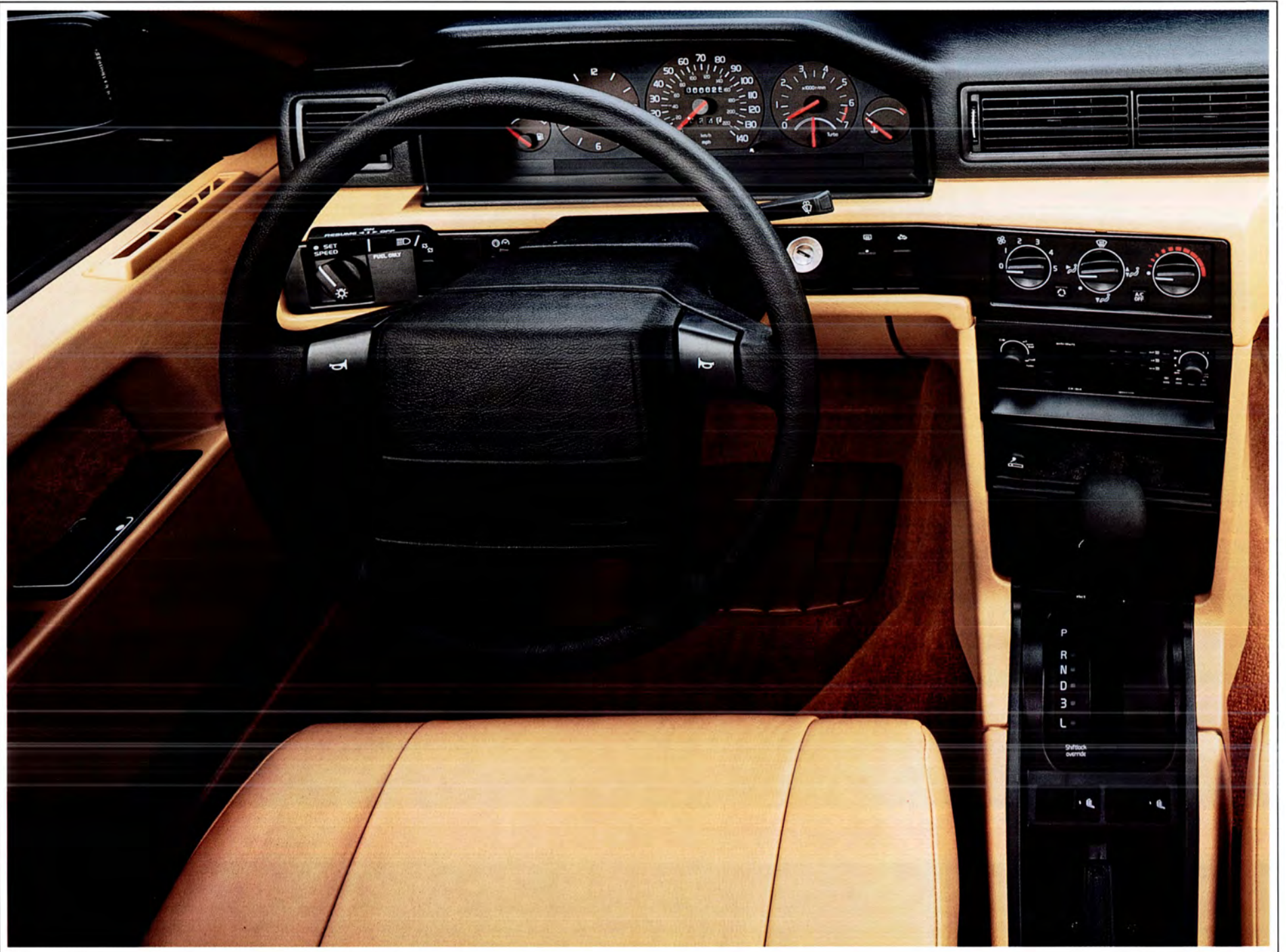

Welcome to the Volvo 940 interior.

Seats are contoured to accommodate and support the body. The power driver's seat provides memory positions for three drivers. All seating positions for a family of five benefit from the protection of the Volvo 3-point seat belt and padded head restraint. The center rear position provides an integrated child's booster cushion.

Doors swing wide to provide easy access to the spacious interior. Ease of access carries over to the low lift trunk design. Volvo's trunk, with stow away spare, and flat floor provides 16.6 cu. ft. of cargo space. For especially long items, Volvo provides the ingenious cargo pass through.

The Volvo 940 offers power/heated mirrors for superior visibility, power windows for convenience, central locking for added security, cruise control for comfort and ozone friendly CFC-free air conditioning for a more comfortable environment inside and outside your Volvo.

All 940s come standard with an AM/FM cassette stereo with anti-theft coding, CD changer compatibility, power antenna and 80 watts of power driving a six speaker layout.

Available in standard trim, or with the optional luxury or Turbo packages, the 940 is the complete family sedan tailored to your specific needs.



A child's booster cushion is built into the rear seat. Head restraints and 3-point seat belts in all three seating positions are also standard.



The 16.6 cubic-foot capacity (0.47 cubic meters) and low liftover height make the trunk easy to use.

240

Rain sweeps across the highway in punishing waves. Every gust of wind assaults the windshield with a torrent of drops that strike heavy on the glass. Road reflections dance as trucks churn rooster tails of spray.

At the wheel of the Volvo 240 you feel comfortable, confident and at ease. Years of refinement have made our 240 the classic family sedan. Flawlessly meeting the needs of thoughtful families, the 240 endures because nothing does it better.

For 5 years in a row *The Complete Car Cost Guide** has judged the Volvo 240 as a "best overall value" in its class. Enhancing the 240's acknowledged high value are industry safety reports that have consistently substantiated the

240's reputation for outstanding occupant protection.**

With tens of thousands of repeat buyers the Volvo 240 has a loyal following that believes it is the best family sedan. Scores of individuals have written to us describing how they feel their 240 helped save their lives. They offer the ultimate testimony to the value of Volvo's steel safety cage construction, energy absorbing body structures and driver's-side air bag.

With ABS four-wheel disc brakes, rack and pinion steering and a suspension benefiting from years of refinement the 240 handles responsively and predictably. Possibly that offers a clue to the great customer loyalty enjoyed by the 240. It delivers the value of proven engineering.

*© 1992 Intellichoice Inc., San Jose, Ca.

**April 1991 INSURANCE INSTITUTE for HIGHWAY SAFETY







Opening a full 70 degrees, the doors of the 240 offer easy access. Our orthopedically designed seats support the body comfortably. Heated front seats,* with adjustable lumbar support provide all-season driving pleasure that leaves you untaxed even after hours on the road.

For a superior driving experience, the 240 rewards the senses with a four-speaker AM/FM stereo cassette sound system. All controls, instruments and gauges display information clearly and function logically with firm and positive action.

Air conditioning, power windows, power locks and dual power/heated mirrors top an extensive list of features on the Volvo 240.

An exceptional level of occupant protection contributes to the 240's reputation as an outstanding value for the money. Our energy absorbing chassis design and driver's supplemental restraint system are silent guardians engineered to help occupants survive a collision.

** Optional*



Our commitment to quality engineering translates into spirited performance, sure-footed handling and excellent braking.

Rear Suspension

Multi-link Independent Rear Suspension featured in the 960 provides exceptional comfort and control while the 940's Constant Track Rear Suspension effectively isolates and dissipates road shock. More traditional in its execution, the 240's live rear axle and coil spring design offers excellent rear wheel tracking. Those who appreciate the classic European ride, handling and predictability will find the Volvo 240 does not disappoint.

Maneuverability

All Volvos boast an extraordinarily small turning diameter. The benefits become quickly evident in tight quarters. Here, Volvo's maneuverability allows you to easily negotiate a tight parking space or cramped U-turn where other cars leave their drivers wrestling with the wheel.

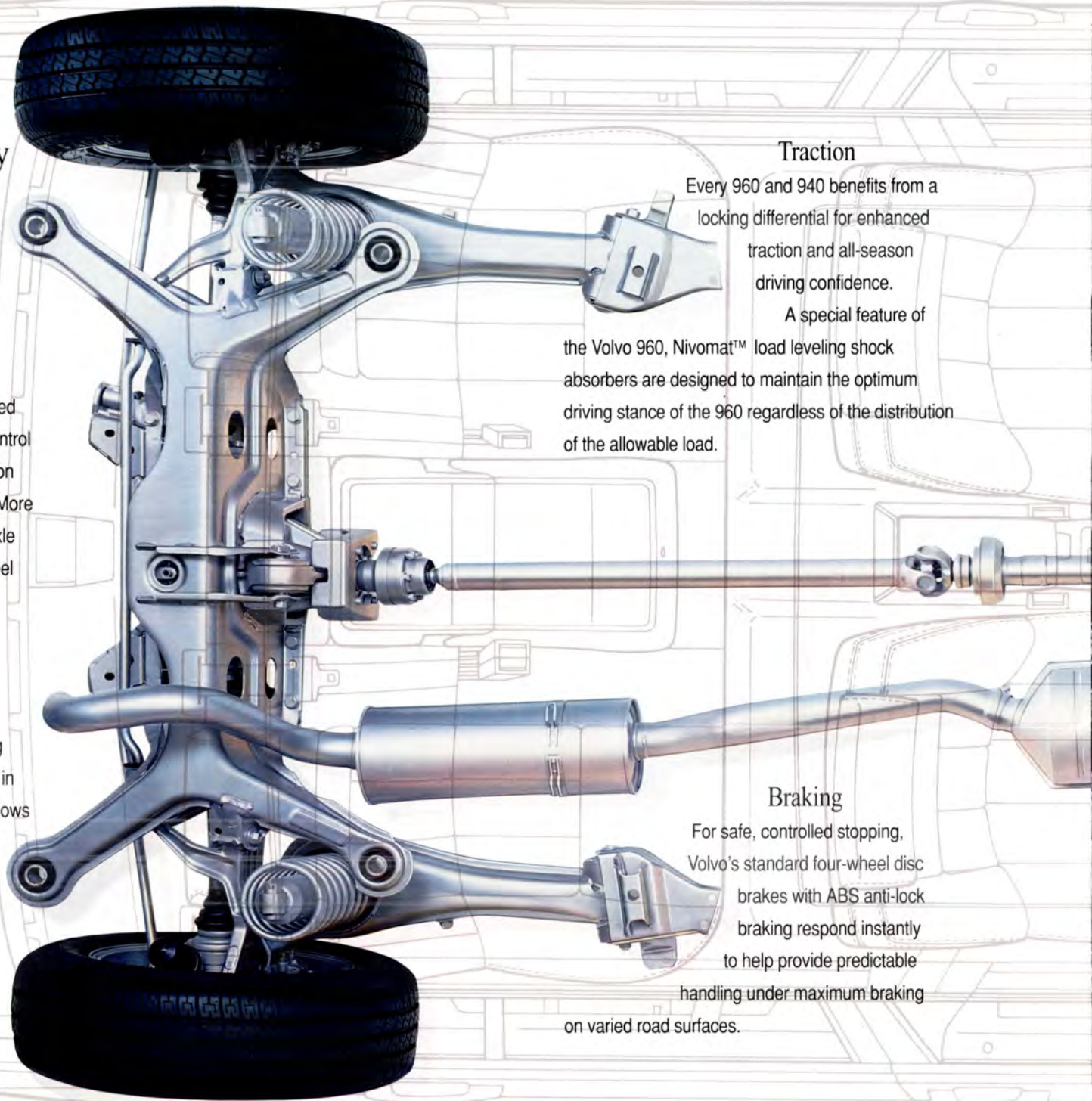

Traction

Every 960 and 940 benefits from a locking differential for enhanced traction and all-season driving confidence.

A special feature of the Volvo 960, Nivomat™ load leveling shock absorbers are designed to maintain the optimum driving stance of the 960 regardless of the distribution of the allowable load.

Braking

For safe, controlled stopping, Volvo's standard four-wheel disc brakes with ABS anti-lock braking respond instantly to help provide predictable handling under maximum braking on varied road surfaces.

Steering

Steering demands accurate road feel and responsiveness. Volvo's refined power-assisted rack and pinion steering provides an excellent feel for the road and sense of control.

Front Suspension

MacPherson strut front suspension ideally complements Volvo's rear suspension and steering designs with its nimble and predictable handling.

Engines

Our family of power plants provides a range of performance tuned engines designed to maximize driving pleasure. The 960's 24 valve, 201 horsepower in-line six delivers world class performance and extraordinary refinement. Its

smooth responsiveness and fuel efficiency over a wide torque band and power curve recall the broad shouldered pulling power big luxury sedans used to offer. And indeed, the 960 can tow 3300 lb. (1500 Kg.) effortlessly.

Turbocharged and intercooled, the 940 Turbo puts the driver in command with power to spare. Whether entering traffic, passing or simply enjoying the pleasure of performance on demand, the responsiveness of our "Generation 3" Turbo engine is both exhilarating and confidence inspiring.

Tested and refined to deliver the perfect balance for those seeking performance, reliability and economy, the overhead cam 2.3 liter engine in the 940 and 240 offers electronic fuel injection and Bosch electronic ignition with knock sensor.

Dynamic Safety Features

As a driver or passenger in a new Volvo, you can take comfort in knowing that Volvo continues to demonstrate an unwavering dedication to the advancement of automobile occupant safety.

Minimizing injury from a collision describes only part of our approach to occupant safety design. Equally important is a vehicle's ability to avoid a collision. Volvo defines these two cornerstones of occupant protection engineering as Dynamic Safety - the ability to avoid a collision, and Passive Safety - the ability to prevent injury resulting from a collision.

Certainly the best way to prevent accident related injury is to avoid the accident. Four-wheel power disc brakes with ABS, standard on all Volvos, equips the driver with exceptional stopping power and enhanced vehicle control during maximum braking. ABS helps assure controlled stopping, even when braking hard on a slippery road surface.



Predictability plays a crucial role in sound dynamic safety design. A vehicle that responds with sure-footed consistency gains the driver's confidence and sharpens the driver's ability to

react effectively when the unexpected occurs.

Volvo's power assisted rack & pinion steering faithfully communicates the feel of the road. MacPherson struts deliver precision tracking while complementing the reflexes of the rear suspension. The result is a nimble, responsive road car that confidently responds to driver input with reassuring consistency.



Passive Safety Features

For our suspension to deliver such predictability, a chassis of noteworthy integrity and structural rigidity is essential. Indeed, at Volvo, chassis engineering is viewed as the heart of passive safety design.

Each component is engineered to complement every other component to help maximize occupant protection.

Volvo's steel safety cage construction surrounds the occupants with a rigid protective enclosure designed to maintain its structural integrity in the event of a collision.

In a frontal collision energy absorbing structures are designed to deform to absorb a portion of the energy of impact.

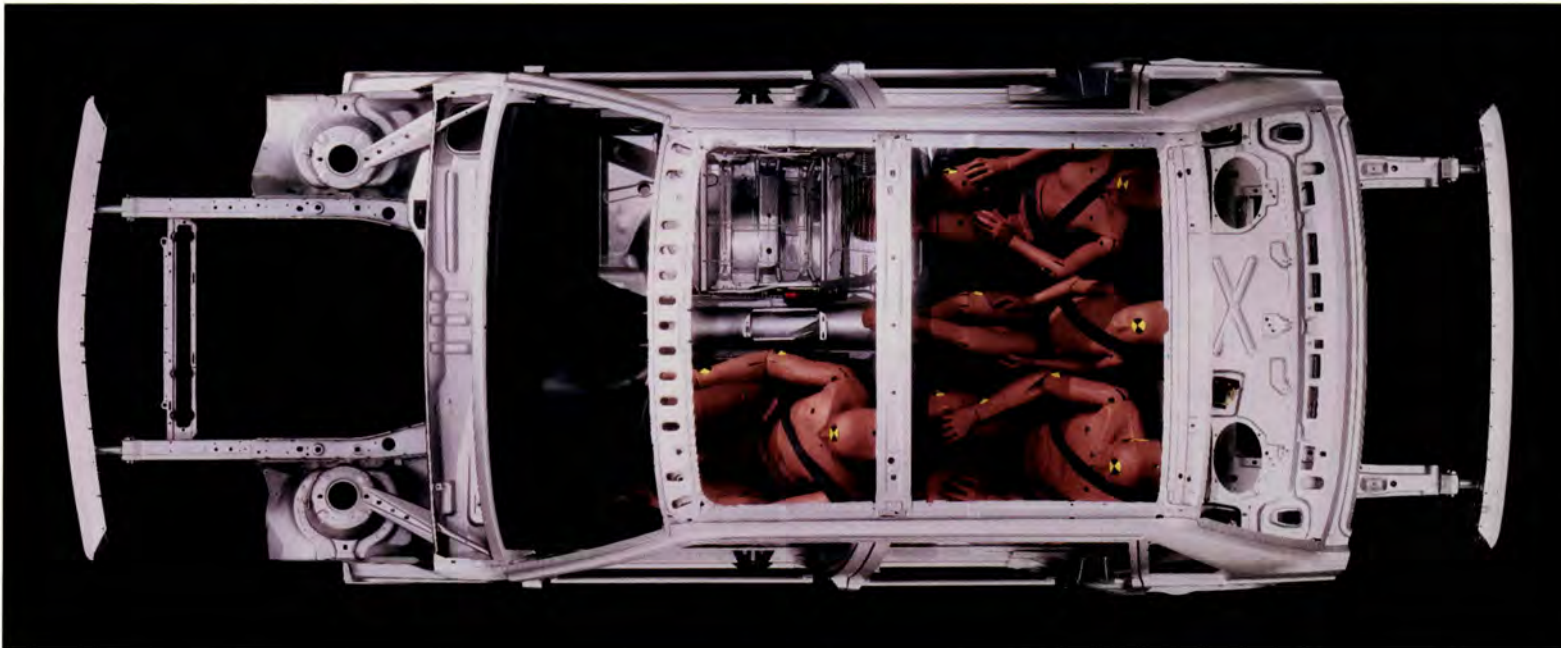

Passive Safety Features

Volvo developed the concept of the three-point seat belt which, today, is the accepted industry standard. All Volvo 900 series models protect with a three-point seat belt and padded head restraint for all five seating positions including the center rear. In addition, both front seat belts include a pretensioner that automatically takes up any slack in the belt during a frontal impact. The 240 provides three-point seat belts and head restraints in the four outboard seating positions, and a traditional lap belt for the center rear.

Seats are designed to work in conjunction with seat belts to maximize seat belt effectiveness. Volvo's anti-submarining seat design and seat belt placement help prevent occupants from sliding down and forward in the event of a frontal collision.

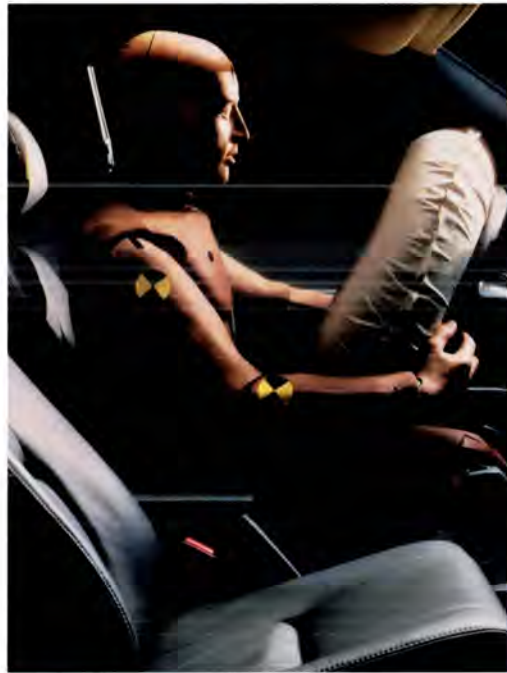
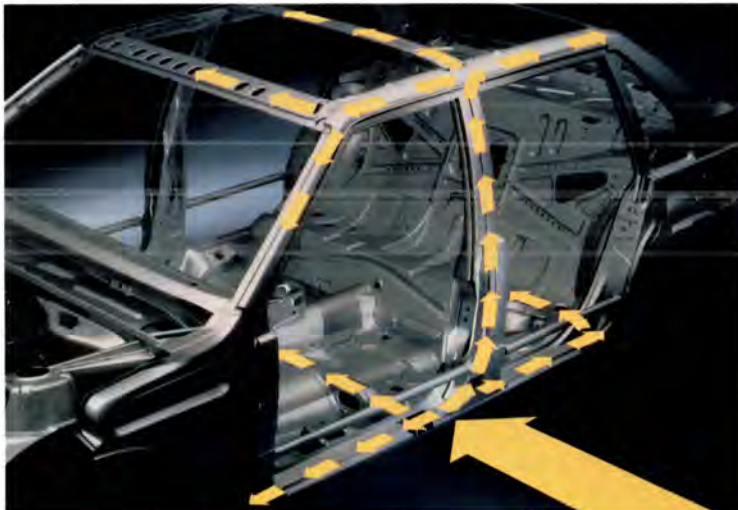

Volvo's Side Impact Protection System represents a major advancement in the protection of occupants involved in vehicle to vehicle side impacts. Standard equipment on all 960 and 940 models, this innovative system of reinforced body elements is designed to help absorb the energy of side impacts through structural members in

the sills, floor, pillars, roof and doors.

All Volvos are equipped with a driver's-side air bag. The 960 provides a passenger-side air bag, as well. The air bag is designed to deploy in the event of certain frontal or front angular impacts. Each is engineered to inflate in milliseconds to help dissipate the energy of the occupant's forward momentum.

An air bag system is often referred to as a Supplemental Restraint System. The word supplemental calls attention to the important fact that an air bag does not, by itself, make a car safe. An air bag should be considered one part of a total safety system, a system in which seatbelts play a fundamental role.

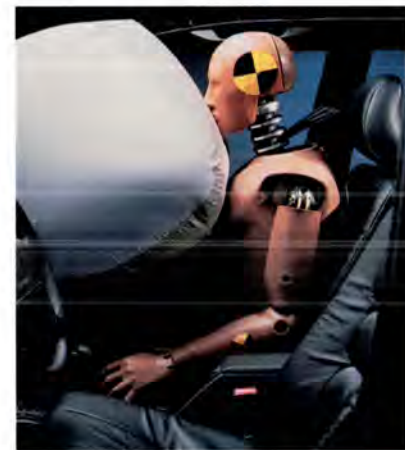

960 passenger side airbag.

Support Programs

1993 Volvo Warranty Coverage

Volvo's limited new-car warranty provides comprehensive coverage for 3 years/50,000 miles. Additional warranties provide coverage for corrosion protection, seat belts, air bags, supplemental restraint systems, emissions systems, spare parts replacement, and genuine Volvo accessories. Please consult the 1993 Warranty Information Booklet for complete details covering all the 1993 Volvo models.

Volvo On Call

Volvo's roadside assistance program can provide you with emergency starts and towing 365 days a year, anywhere in North America. It includes locksmith services, trip routing and travel services. It also provides reimbursement for accommodations, should repairs be required during travel away from home.

Volvo Service Support Network

Volvo's extensive North American dealer network ensures that you can expect the very best service support wherever you go. That is one of the important reasons behind our high level of customer satisfaction. Only trained technicians, using the latest Volvo technology, work at our dealerships. They know everything we can teach them about keeping your Volvo running beautifully, year after year.

Genuine Volvo Parts

You probably never think about the thousands of parts that make up your Volvo. That's good. That's the whole point of all the rigorous quality inspections every Genuine Volvo Part must pass. From radiator hoses to critically machined gears, they are all expected to provide performance equal or superior to the parts they replace. Genuine Volvo Parts. They are more good reasons to consider Volvo for your next automobile.

VIP: The Volvo Increased Protection Plan

This extended service contract provides exceptional protection against unexpected mechanical difficulties. It allows you the flexibility to pick the plan term that best suits your driving needs.

Long after the factory warranty expires, the Volvo Increased Protection plan can pay for towing and rental expenses while a covered breakdown is being repaired. The Volvo Increased Protection plan is the only service agreement program backed by Volvo Cars of North America.

Customer Assistance

Your Volvo dealer will be happy to answer any questions you may have on the 1993 Volvo models shown in this catalog. If you require additional information, you can contact Volvo Consumer Affairs at 1-800-458-1552, Monday through Friday, 8:AM to 7:PM, Eastern Standard Time.

Some of the information in this catalog may be incorrect due to product changes which may have occurred after this book was printed. Some of the equipment described or shown may now be available only at extra cost. Before ordering, please ask your Volvo dealer to bring you up to date. The manufacturer reserves the right to make changes at any time, without notice, to prices, color, materials, specifications and models.



Dealer Installed Options

Explore Volvo's extensive line of dealer installed options and personalize your new Volvo to fit your driving needs. From armrests to roof rack systems, dealer installed options extend the functional nature of your Volvo as they add to your driving pleasure.

Installed by your Volvo dealer, Volvo options offer factory quality features and have been designed and manufactured to the same exacting standards as your new Volvo.

Consult Volvo's dealer installed options brochure for a complete listing.

Trunk Liner - High edges hold spilled liquids and dirt. Easily removed for convenient cleaning.



Floor Protection Set - Protects carpets from soil and water. Easily removed for convenient cleaning.

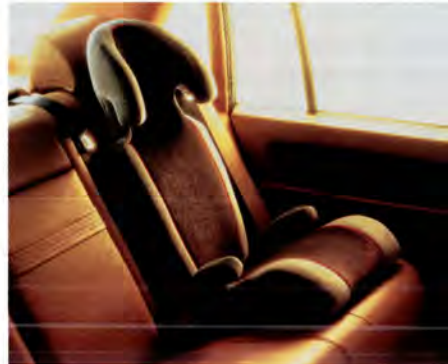

Child Cushion and Backrest - Provides extra seating height for children and allows for comfortable and proper use of seat belt.



Armrest with Beverage Holder - Convenient sliding tray design provides beverage holders for front and rear passengers. It holds up to four beverages or cups. The elevated armrest enhances driving comfort.

Roof Rack System - Adaptable, removable and ruggedly constructed. Optional holders for bicycles, skis, luggage and sailboards are available. It supports up to 220 lbs. (100 kg.).





Rear Deck Spoiler - Adds distinctive, performance oriented visual accent to any 900 series sedan.

Rear decor panel - Unifies the taillight area for a wraparound effect.

Compact Disc Changer - Holds six CDs.
Your Volvo radio is preadapted to accept changer.
The CD changer is trunk mounted to deter theft.



All Weather Lights - Improves visibility for added safety in inclement weather.



Winter Tires - For superior wet weather traction to help maintain your Volvo's driving and braking characteristics on ice and snow. Four winter tires are recommended.

Features

240

Driver's-side supplemental restraint system (air bag and knee bolster)
Anti-lock brake system (ABS)
Four, 3-point, inertia-reel seat belts; rear center lap belt
Rear fog light
Air conditioning (CFC-free system)
AM/FM stereo cassette with

4 x 20W amplifier, four coaxial speakers and anti-theft circuitry
Power antenna
Tinted windows with front windshield shade band
Power windows with rear window lock out
Central power door locking system, including trunk

Dual, heated, anti-glare power mirrors
Rear-window defroster with timer
Two-speed windshield wipers with intermittent cycle
Child-seat top-tether anchorages, rear seat (three)
Adjustable lumbar support
Heated front seats*

Four, front and rear head restraints
Front and rear floor mats
Carpeted luggage compartment
Long-load pass-through to trunk
Illuminated, lockable glove compartment
Front passenger visor vanity mirror
Front-door-panel storage pockets
Luggage compartment light

Interior cabin light delay
Halogen headlights**
Tool kit

* Optional in the United States; standard in Canada.
** Daytime running lamps are standard in Canada.

940

Driver's-side supplemental restraint system (air bag and knee bolster)
Automatic seatbelt pretensioners for driver and front-seat passenger
Seat belts: five 3-point, inertia-reel belts
Side Impact Protection System
Integrated child booster cushion in rear center armrest*
Five padded head restraints (center-rear is adjustable)
Eight-way power adjustable driver's seat with 3-position memory function
Adjustable lumbar support

Heated front seats
Illuminated, lockable glove box
Illuminated vanity mirror in front passenger's sun visor
Front door-panel storage pockets
Front seat back storage pockets
Two-speed windshield wipers with intermittent cycle
Rear-window defroster
Interior cabin light delay
Front-seat reading lights
Warning lamps in doors
Halogen headlights**

Rear fog light
Air conditioning (CFC-free system)
AM/FM cassette stereo with anti-theft coding, power antenna, 6 speakers
Power windows with rear-window lock-out feature
Cruise control
Locking differential (for improved traction on slippery surfaces)
Anti-lock brake system (ABS)
Tinted windows
Central power door locks, including trunk
Dual, heated, power mirrors

Long-load pass-through to trunk
Luggage compartment light
Tricot plush cloth upholstery
Tool kit
Front and rear plush floor mats
Prewiring for optional security system and outside ambient temperature gauge

940 Luxury Package (Opt #1) includes:

Twenty-spoke alloy wheels
Power sunroof with tilt and slide functions
Leather-faced upholstery
AM/FM "full-logic" cassette stereo with CD capability

940 Turbo Package (Opt #2) includes option #1 plus:

Turbocharged 2.3 liter engine with intercooler
Front fog lights
"H" speed rated 195/65 tires
Distinctive grey "eggcrate" style grille
Color-keyed bumpers on metallic colors

* For children age 3 and over weighing between 50 and 80 lbs. (23 - 36 kg) and between 46 and 54 in. (117 and 137 cm) in height.
** Daytime running lamps are standard in Canada.

960

Driver's-side supplemental restraint system (air bag and knee bolster)
Front passenger's supplemental restraint system (air bag and knee bolster)
Automatic seatbelt pretensioners for driver and front-seat passenger
Seat belts: five 3-point, inertia-reel belts
Side Impact Protection System
Integrated child booster cushion in rear center armrest*
Five padded head restraints (center-rear is adjustable)
Adjustable lumbar support

Eight-way power adjustable driver's and front passenger's seats with 3 position memory function on the driver's seat
Dual, heated, power mirrors
Two-speed windshield wipers with intermittent cycle
Rear-window defroster
Interior cabin light delay
Front and rear reading lamps
Warning lamps in doors
Halogen headlights**
Front fog lights

Rear fog light
Electronic climate control (CFC-free system)
Large format AM/FM cassette stereo with anti-theft coding, amplifier, power antenna, CD capability and 6 speakers
Power windows with rear-window lock-out feature
Power sunroof with tilt and slide functions
Cruise control
Locking differential
Anti-lock brake system (ABS)

Tinted windows
Central power door locks, including trunk
Heated front seats
Leather-wrapped steering wheel
Three-position tilt steering column
Illuminated, lockable glove box
Illuminated vanity mirrors in driver's and front passenger's sun visors
Front door-panel storage pockets
Front seat back storage pockets
Long-load pass-through to trunk
Luggage compartment light

Leather-faced upholstery
Plush front and rear floor mats
Tool kit
Prewiring for optional compact-disc changer, optional security system, and outside ambient temperature gauge

* For children age 3 and over weighing between 50 and 80 lbs. (23 - 36 kg) and between 46 and 54 in. (117 and 137 cm) in height.
** Daytime running lamps are standard in Canada.

Specifications

Engines

240

2.3 liter, single overhead cam, 4-cylinder,
Bosch electronic ignition system with knock sensor,
Bosch LH-lambda electronic fuel injection

Horsepower (SAE net): 114 @ 5400 rpm
Torque (ft./lbs., SAE net): 136 @ 2700 rpm
Fuel capacity: 15.8 US gallons (60 liters)

940

2.3 liter, single overhead cam, 4-cylinder,
electronic ignition system with knock sensor,
electronic fuel injection

Horsepower (SAE net): 114 @ 5400 rpm
Torque (ft./lbs., SAE net): 136 @ 2750 rpm
Fuel capacity: 19.8 US gallons (75 liters)

940 Turbo

2.3 liter, single overhead cam, turbocharged and
intercooled, 4-cylinder, electronic ignition system
with knock sensor, electronic fuel injection

Horsepower (SAE net): 162 @ 4800 rpm
Torque (ft./lbs., SAE net): 195 @ 3450 rpm
Fuel capacity: 19.8 US gallons (75 liters)

960

2.9 liter, double overhead cam, all alloy, 24-valve,
6-cylinder with Bosch Motronic 1.8 fuel injection,
Bosch Motronic 1.8 distributorless ignition with
knock sensor system

Horsepower (SAE net): 201 @ 6000 rpm
Torque (ft./lbs., SAE net): 197 @ 4300 rpm
Fuel capacity: 21.0 US gallons (80 liters)

Transmissions

240

5-speed manual with overdrive fifth gear*
Optional, 4-speed automatic with overdrive fourth gear

940

4-speed automatic with overdrive fourth gear

960

4-speed electronically-controlled automatic with
selectable shift modes (Economy/Sport/Winter)

Suspensions

240

Front: MacPherson strut with coil springs,
hydraulic shock absorbers, stabilizer bar

Rear: Live rear axle with trailing arms,
panhard rod, coil springs, hydraulic shock absorbers,
stabilizer bar, optional locking differential

940

Front: MacPherson strut with coil springs,
hydraulic shock absorbers, stabilizer bar

Rear: Constant track live rear axle, trailing arms,
panhard rod, coil springs, gas charged shock
absorbers, stabilizer bar, locking differential

960

Front: MacPherson strut with coil springs,
hydraulic shock absorbers, stabilizer bar

Rear: Multilink independent rear suspension
with lower trailing arms, upper wishbones,
lower link and track rod, coil springs,
Nivomat self-leveling shock absorbers,
stabilizer bar, and locking differential

* Not Available in California.

Tires

240

185R14T tires; 5.5" x 14" steel wheels

940

185/65R15T; all-season tires; 6" x 15" steel wheels

940 Option 1 (Luxury Package):

185/65R15T; all-season tires; 6" x 15" alloy wheels

940 Option 2 (Turbo Package):

195/65R15H; 6" x 15" alloy wheels

960

195/65R15V; 6" x 15" alloy wheels

Steering

Power-assisted rack and pinion
32.2 ft. turning circle (9.8 m)
3.5 turns, lock to lock

Brakes

240

Four-wheel, power-assisted disc brakes with
anti-lock braking system (ABS); separate
self-adjusting rear-wheel drum parking brakes

940

Four-wheel, power-assisted disc brakes; ventilated
front discs; front and rear pressure proportioning
valve, anti-lock braking system (ABS); separate
self-adjusting rear-wheel drum parking brakes

960

Four-wheel, power-assisted disc brakes; ventilated
front discs; front and rear pressure proportioning
valves, anti-lock braking system (ABS); separate
self-adjusting rear-wheel drum parking brakes

Dimensions and Weights

240

Wheelbase	104.3 in.	265 cm
Overall length	189.9 in.	482 cm
Overall height	56.3 in.	143 cm
Overall width	67.3 in.	171 cm
Front track	56.3 in.	143 cm
Rear track	53.5 in.	136 cm
Curb weight	2943-3018 lbs.	1335-1369 kg.
Towing capacity	3300 lbs.	1500 kg
Trunk capacity	14.0 cu. ft.	0.4 m ³

940

Wheelbase	109.1 in.	277 cm.
Overall length	191.7 in.	487 cm.
Overall height	55.5 in.	141 cm.
Overall width	68.9 in.	175 cm.
Front track	57.5 in.	146 cm.
Rear track	57.5 in.	146 cm.
Curb weight	3208-3230 lbs.	1455-1465 kg
Towing capacity	3300 lbs.	1500 kg
Trunk capacity	16.6 cu. ft.	0.47m ³

960

Wheelbase	109.1 in.	277 cm.
Overall length	191.7 in.	487 cm.
Overall height	55.5 in.	141 cm.
Overall width	69.3 in.	177 cm.
Front track	57.8 in.	147 cm.
Rear track	59.8 in.	152 cm.
Curb weight	3508 lbs.	1591 kg.
Towing capacity	3300 lbs.	1500 kg.
Trunk capacity	16.6 cu. ft.	0.47 m ³



© 1992 Volvo Cars North America Inc., Rockleigh, NJ 07647
Volvo Canada Ltd., North York, Ont., M2H 2N7

VOLVO
Drive Safely™

Printed in U.S.A. C202 8/92 N.A.
"Drive Safely" is a trademark belonging
to Volvo Cars North America Inc.