

VOLVO SURVIVAL STORIES.

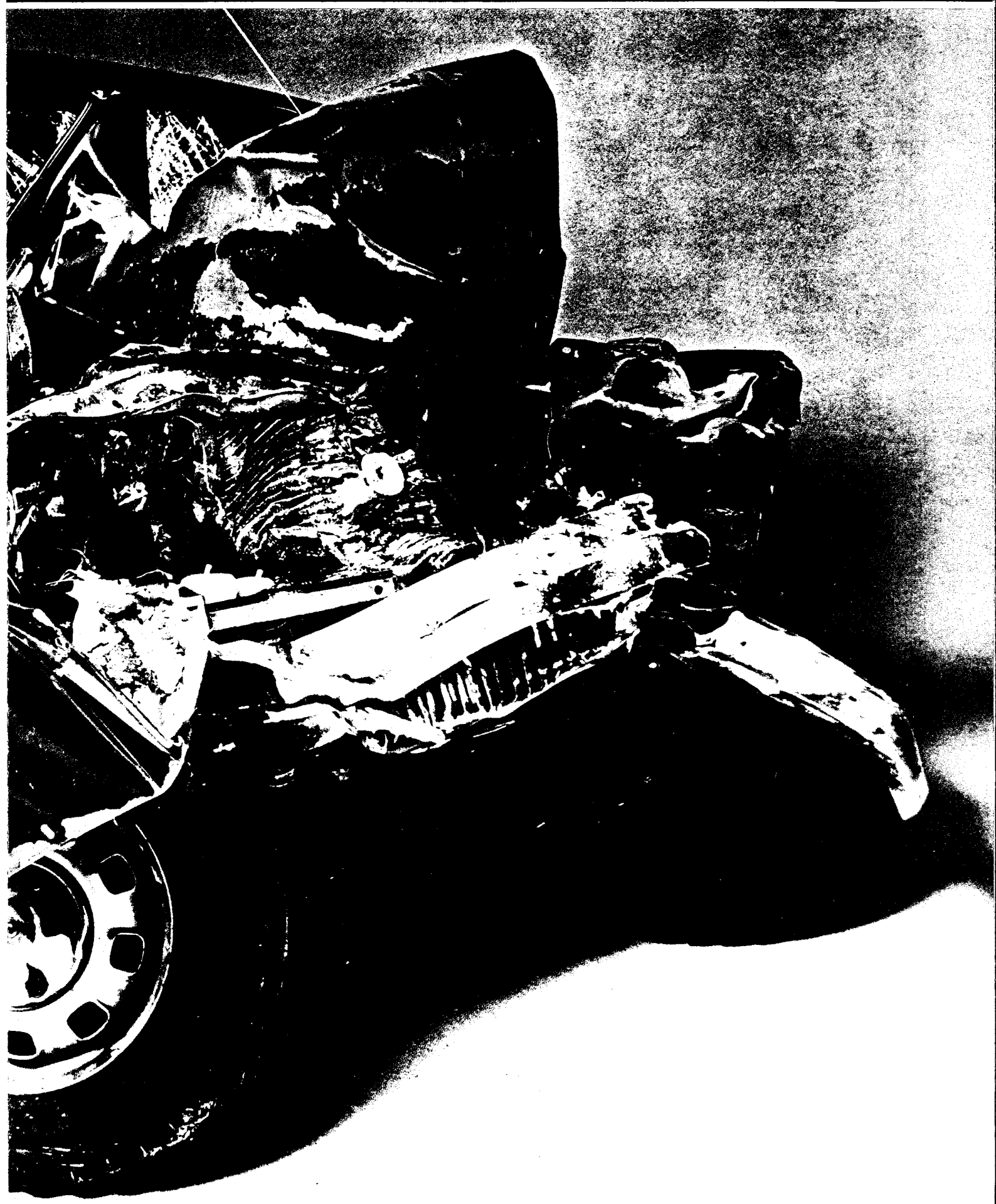

SURVIVAL STORY No.1

Mr. & Mrs. L.E. Hawkins, 15 Bulah Close, Berowra Waters, N.S.W.

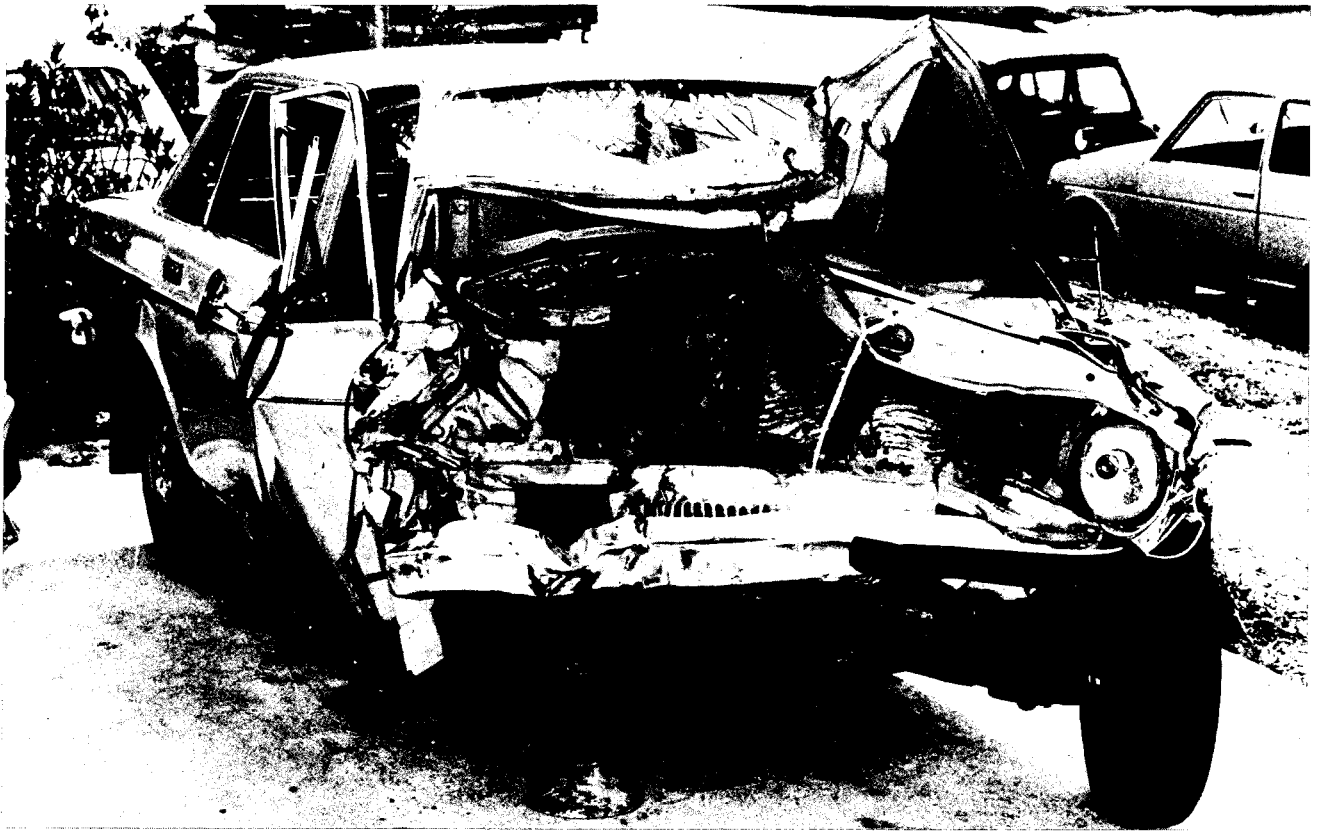

Volvo Australia Pty. Ltd.,
Box 122, P.O.,
Liverpool,
New South Wales, 2170.

Attention: Mr. J. Anger, Export Manager.

Dear Mr. Anger,

As you may recall, I, the undersigned, purchased a new Volvo 145E through Albion Motors, Brisbane, in September, 1974. Prior to that time, I owned a Volvo 144 deluxe, which I sold to my brother-in-law, Mr. Laurence Hawkins, of 15 Bulah Close, Berowra Heights, N.S.W.

Laurence and his wife were involved in a head-on collision with another car on 27th April last. Collision speed was probably in excess of 150 m.p.h., (the speedometer of the other vehicle had locked at 100 m.p.h.). Both vehicles were a write-off and at least one person died as a result.

Laurence and his wife were fortunate in the fact that they were driving a Volvo. Both "walked away" from the accident, although Laurence has sustained serious facial injuries and his wife other relatively minor injuries. It is quite obvious that the Volvo has saved their lives.

Human nature being what it is, it is all too often we are ever so ready to complain, but fail to give credit where it is due. This prompts me to write this letter, and ask that you accept our congratulations and thanks for producing such a safe, and reliably so, car. The Volvo performed exactly as your advertising claims it will; all your claims have been substantiated.

We are very satisfied customers and a very grateful family.

Yours faithfully,

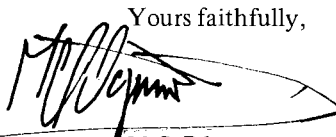

M.C. Pilgrim.

Actual letters on file at Volvo Australia head office.

VOLVO
SURVIVAL OF THE FITTEST.

SURVIVAL STORY No.2

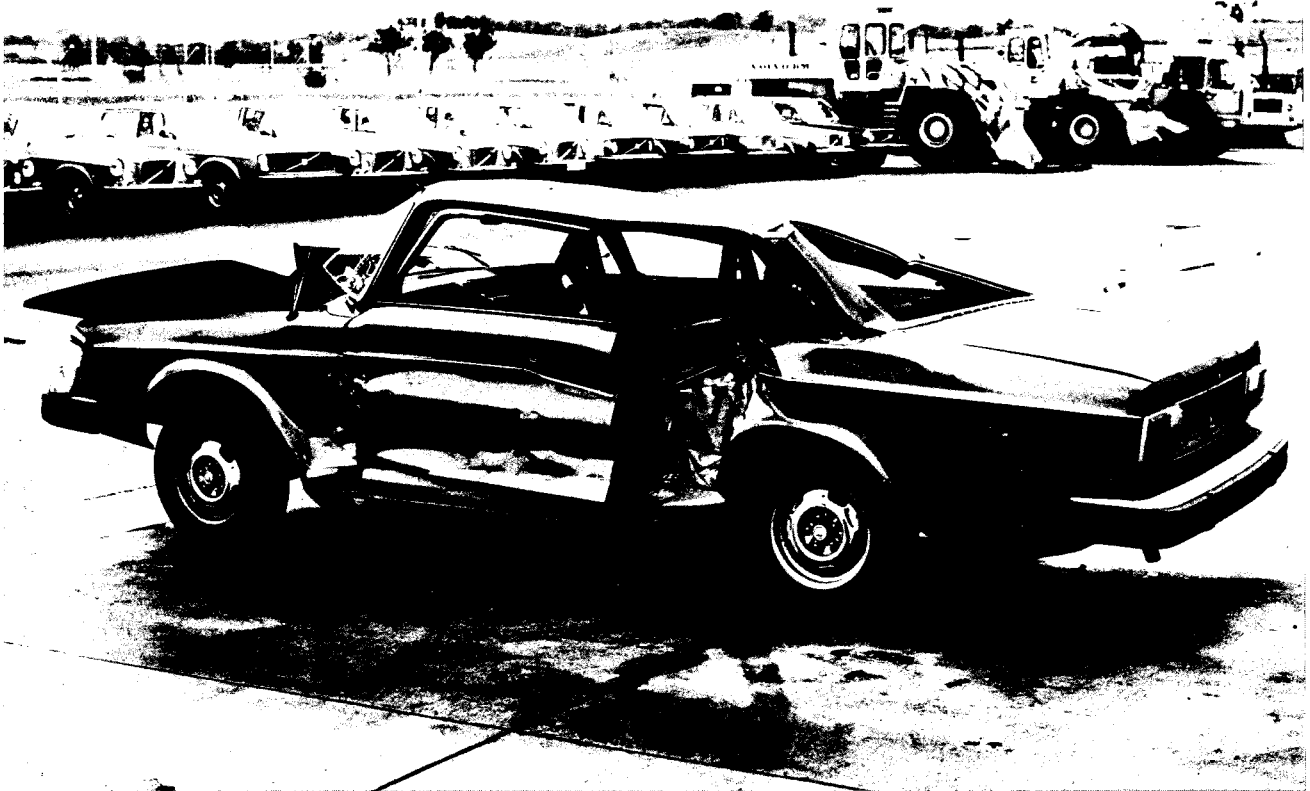
Mr. Rob Harrison, 3 Bloomsbury Road, Pymble, N.S.W. 2093.



3 Bloomsbury Road,
Pymble, N.S.W. 2093.

14th May, 1975.

Mr. D. Blair,
N.S.W. Regional Manager,
Volvo Australia,
Airds Road,
Minto. N.S.W. 2566.

Dear Don,

As a Volvo Sales representative, I've always been keenly aware that one of the most important reasons for buying it is the one thing I can't demonstrate on a test run. Comfort, yes. Performance, yes. Road holding and braking, yes. But Volvo secondary safety, the ability to save life when an accident can't be avoided, is something I've just had to talk about. Then, one Saturday night, I received my own personal, unplanned 'demo'.

Oddly enough, our accident was - almost - a carbon copy of one we had just passed. A two door coupe had been hit from the left, killing the front seat passenger. The driver appeared badly injured and was receiving treatment, and a passenger trapped in the back was being cut free by the police. Shocked by what we had seen, we proceeded somewhat cautiously until, with no time for evasion, a car rocketed out from the left and ploughed into the left-hand door of our Volvo 242.

His speed, estimated at over 120 k.p.h., was sufficient to roll us over three times. The first time, we landed on the roof. I saw the high impact laminated windscreen craze and change shape as its aperture deformed, but Volvo's pillars and built-in roll bar did their job. We bounced over a second time onto the roof; the third time pivoting on the bonnet, smashing the grille and headlights before coming to rest on all four wheels. Almost as if nothing had happened. Releasing the seat belt, I wondered for a moment if my buckled door would open. It did. Even more surprisingly, my brother was able to jump out of his door, the one that had been hit first. My mother, in the rear seat was less fortunate. She had received cuts from flying glass. But nothing was broken.

A lucky escape from an unforeseeable disaster? I thought so at the time. But on reflection, you could say it had been foreseen, and provided for, by the designers of the Volvo 'safety capsule'. Which is one reason I'm happy to be a Volvo salesman.

Yours faithfully,

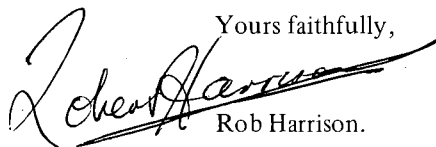
Rob Harrison.

VOLVO
SURVIVAL OF THE FITTEST.

SURVIVAL STORY No.3

Dr. Edward G. Bosch, 9 Drumalbyn Road, Bellevue Hill. N.S.W. 2023.



9 Drumalbyn Road,
Bellevue Hill. N.S.W. 2023.

Mr. W. Hagon,
Volvo Australia Pty. Ltd.,
P.O. Box 122,
LIVERPOOL. N.S.W. 2170.

Dear Mr. Hagon,

Re: Motor Vehicle Accident March 23, 1975.

I am a licensed driver with 24½ years driving experience. I am the owner of a Volvo sedan (Model 164E - 1972) and was driving the vehicle at the time of the accident. In my vehicle there was one passenger in the front near side seat; the passenger was my son, Edward Anthony Bosch, aged 14 years. My occupation is "medical practitioner".

At approximately 7.45 p.m. on Sunday, 23rd March, I was driving my vehicle above mentioned north along Menangle Road, Menangle. I would estimate my speed at 40 m.p.h. but it may have been slower than this. I approached the right hand bend (opposite the junction with Cummins Road) well on the left hand side of the road and several feet to the left of the centre line. Suddenly I saw a car coming towards me at what appeared to be a very fast speed. The car crossed over on to my side of the road and it appeared to be in a "skid" and "out of control". I immediately applied my brakes but our cars collided.

My son and I both walked away from the accident.

Yours faithfully,

Edward G. Bosch

(Edward Graham Bosch)
M.B.B.S., M.R.C.O.G., F.A.G.O.

VOLVO
SURVIVAL OF THE FITTEST.

NEW VOLVO. 20% SAFER. TAKE IT FROM SVEN.



1. Sven is an electronically monitored humanoid used to evaluate passenger protection in Volvo's Safety Research Programme...

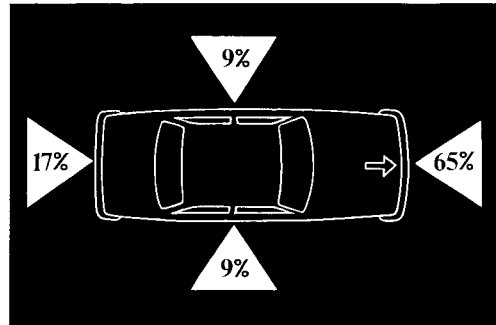

2. ...together with actual accident studies, which show front-end collisions to be the most frequent and potentially lethal.

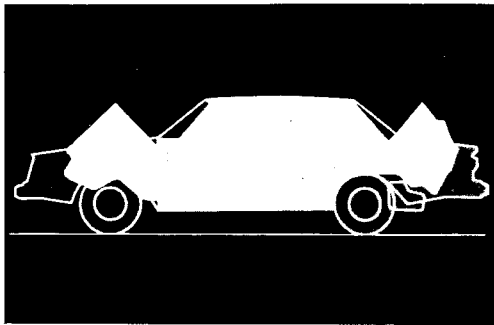

3. Result—Volvo's new safety capsule body with longer 'crumple zones' giving 20% more front-end energy absorption.

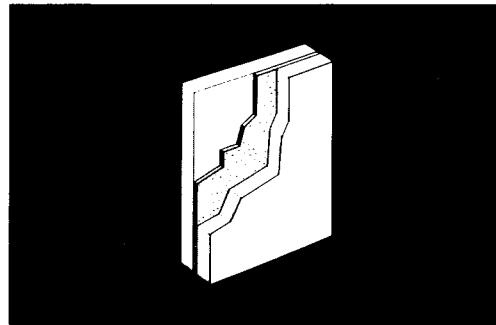

4. High impact windscreen lamination prevents passenger ejection and reduces risk of lacerating injuries.

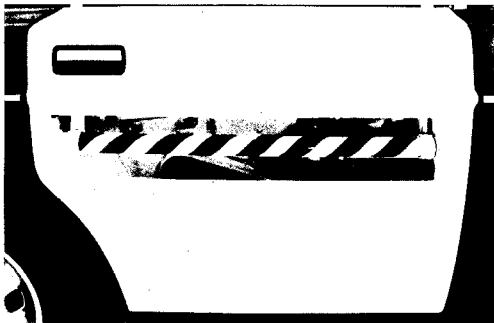

5. Tubular steel side impact barriers in all four door, plus a roll bar in the roof, complete Volvo's all-round protection.

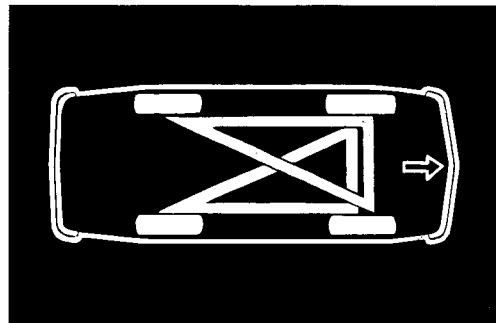

6. Volvo's triangle-split dual brake circuits with new stepped-bore master cylinder. No extra pedal pressure needed if one circuit fails.

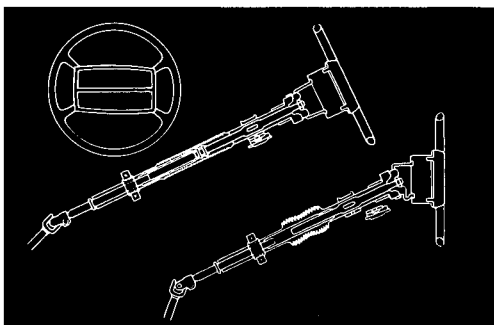

7. Safety steering features bolstered hub, impact spreading crumple zone, and three separate column collapse points.



8. Energy absorbing bumpers prevent structural damage to body in 'parking speed' impacts up to 5 k.p.h.

*Comparative collisions tests on 240 and 140 series carried out at Volvo Safety Laboratory, Gothenburg Sweden.

VOLVO
SURVIVAL OF THE FITTEST.

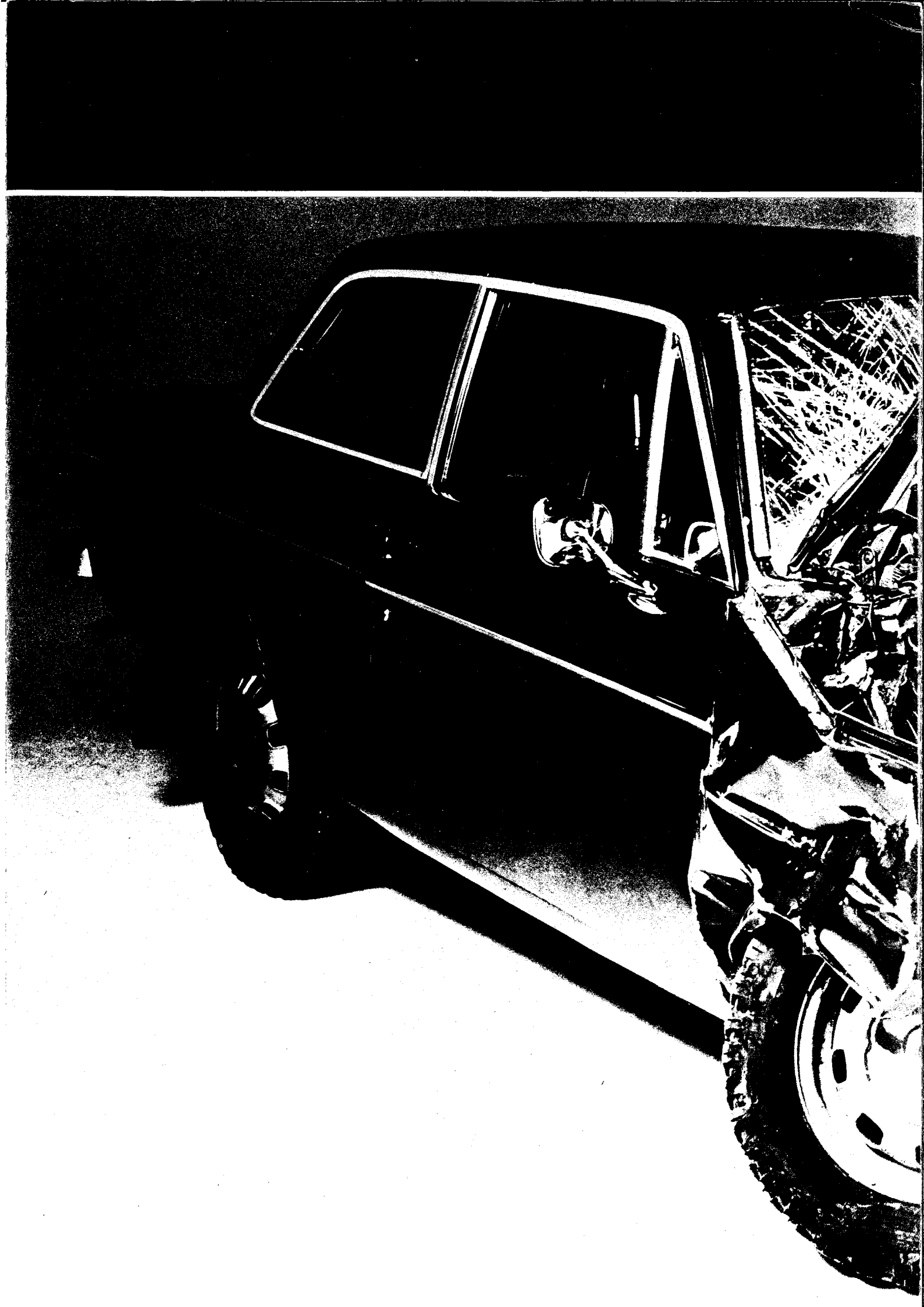

A Swedish investigation shows:

61% less risk of a fatal accident in a Volvo.

Throughout 1973, 569 motor vehicles in Sweden were involved in accidents which had fatal consequences for 644 persons – either drivers or passengers.

All kinds of cars were involved, for Sweden is one of the countries in the world in which the greatest number of car makes are sold.

The accident research department at Volvo, Gothenburg, has now investigated each of these serious accidents in order to evaluate car safety in actual traffic situations. And in order to obtain a realistic basis for future car engineering.

The research department worked closely with the Swedish authorities on accident statistics on this investigation – and used impartial statistical information.

Fewer fatal accidents in Volvos.

Based on their market share plus the fact that the Volvo 140-series and 164 are driven 15% more than the average car in Sweden, Volvos were expected to have been involved in 74 of the total number of fatal accidents.





But in reality, the investigation showed that they were only involved in 29 of them (39% of the expected number)!

Volvos proven to be at least 70% safer in actual head-on collisions.

The Volvo research group also investigated the various types of accidents and analysed the actual Volvo safety in each situation.

Generally, head-on collisions (with a motor vehicle, truck, bus, tree, street sign etc.) were the most common.

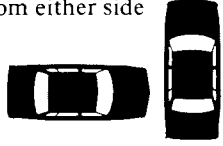
The conclusion from this part of the analysis revealed that the Volvo

Actual accident safety of the Volvo 140-series and 164 compared with the expected safety.	Actual number of fatal accidents	Expected number of fatal accidents
Collisions with vehicles moving in the same direction 	1	3
Collisions with vehicles moving in the opposite direction 	10	31
Collisions with vehicles from either side 	7	11
Single accident 	11	29
Total	29	74

140-series and 164 only had 29% of the total number of expected Volvo fatalities!

82% survival level in a Volvo.

It was also ascertained by the investigation that built-in Volvo safety really works when it comes to collisions with other passenger cars – collisions with fatal results.

Only 18% of the total number of Volvos that were involved in such

accidents had fatalities (a degree of survival therefore of 82%).

The second best car, of comparative size, had a survival degree of 69%. The average survival rating for all other car makes with a representation of more than 100,000 registered vehicles was only 34%.

Yet, the new Volvos have been proven even safer.

The Volvos involved in the Swedish investigation were the previous 140-series and the 164.

But Volvo have tested their new 240-series in the safety laboratory.

The new Volvos have been tried in head-on collisions into concrete barriers at 65 km p.h.

The results of all the tests show that occupant protection in the new Volvos is vastly superior even to that of the 140-series.

In equivalent comparison tests, the collision effects on the occupants are reduced by more than 20% in the new Volvos!

Now don't you think that's worth considering when you're choosing a new car for yourself and your family?

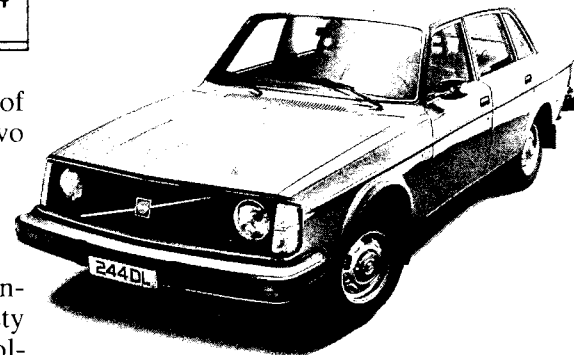

VOLVO

We can prove what we say.