

VOLVO 262 264 265



OWNER'S MANUAL 1976 USA/CANADA

Notice to Owner: Your Volvo has been built to comply with all North American safety and anti-pollution regulations and evidence of this can be verified from the certification labels attached to the door opening sheet metal and on the left wheel housing in the engine compartment. For further information regarding these regulations, please talk to your local dealer.

Personal Information

Name R. W. McARDLE

Address 819 MONROE

City, State ANOKA, MINN

Tel. No. 421-3515

Car Information

Vehicle Identification Number (VIN) 26565E2-006799

Ignition Key No. 8150

Door Key No. 5374

DESCRIPTION	Page	MAINTENANCE SERVICE	
Introduction	2	Maintenance Services	39
Keys	3	Gas station checks	40
Instruments and controls	4	Maintenance schedule	42
Instruments	6	Engine compartment	45
Warning lights	7	Emission control system	48
Ignition switch, parking brake	8	Transmission oils	56
Lighting	9	Rear axle, power steering, brake fluid	57
Turn signals	10	Lubrication	58
Wipers	11	Coolant	59
Clock, cigarette lighter, ash tray		Note: alternator	60
electrically operated window winder	12	Replacing bulbs	60
Tail gate window wiper,		Fuses	64
electrically heated rear window,		Wheels and tires	65
hazard warning flasher	13	Wheel changing	66
Heating and ventilation	14	Washing, cleaning	68
Air conditioning	16	Cleaning, anti-rust treatment	69
Front seats	18	Paint touch-up	70
Seat belts	20	Long distance trips	72
Doors and locks	22	Cold weather	73
Rear doors, trunk lid	23	Service diagnosis	75
Hood	24	Specifications	80
Vent windows, rear view mirrors	25	Consumer information	86
Interior light, sun roof, fuel tank cap	26		
Rear seat, model 265	27	INDEX	91
Tail gate, model 265	28		
 START AND DRIVING			
Breaking in	31		
Starting the engine	32		
Gear shift positions	33		
Automatic transmission	34		
Emergency towing	36		
Trailer hauling	37		
Note	38		

General Information

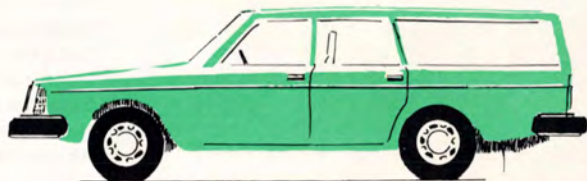
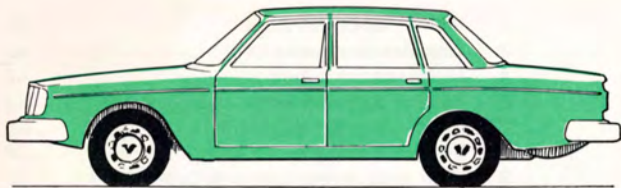

Model versions of the basic Volvo Models 262/264/265

- Volvo 262 Grand Luxe (2 doors)
- 264 Grand Luxe (4 doors)
- 264 de Luxe (4 doors)
- 265 de Luxe (Wagon)

Volvo reserves the right to change specifications or design, at any time without notice and without incurring obligation. Designs as shown in this Manuel may be altered.



Front doors
Trunk
Glove box

No. 5374.....



Ignition/Steering wheel lock

No. 8150.....

Record the number code of the keys. In the event the original keys are lost, duplicates can be ordered through your Volvo dealer.

Instruments and Controls

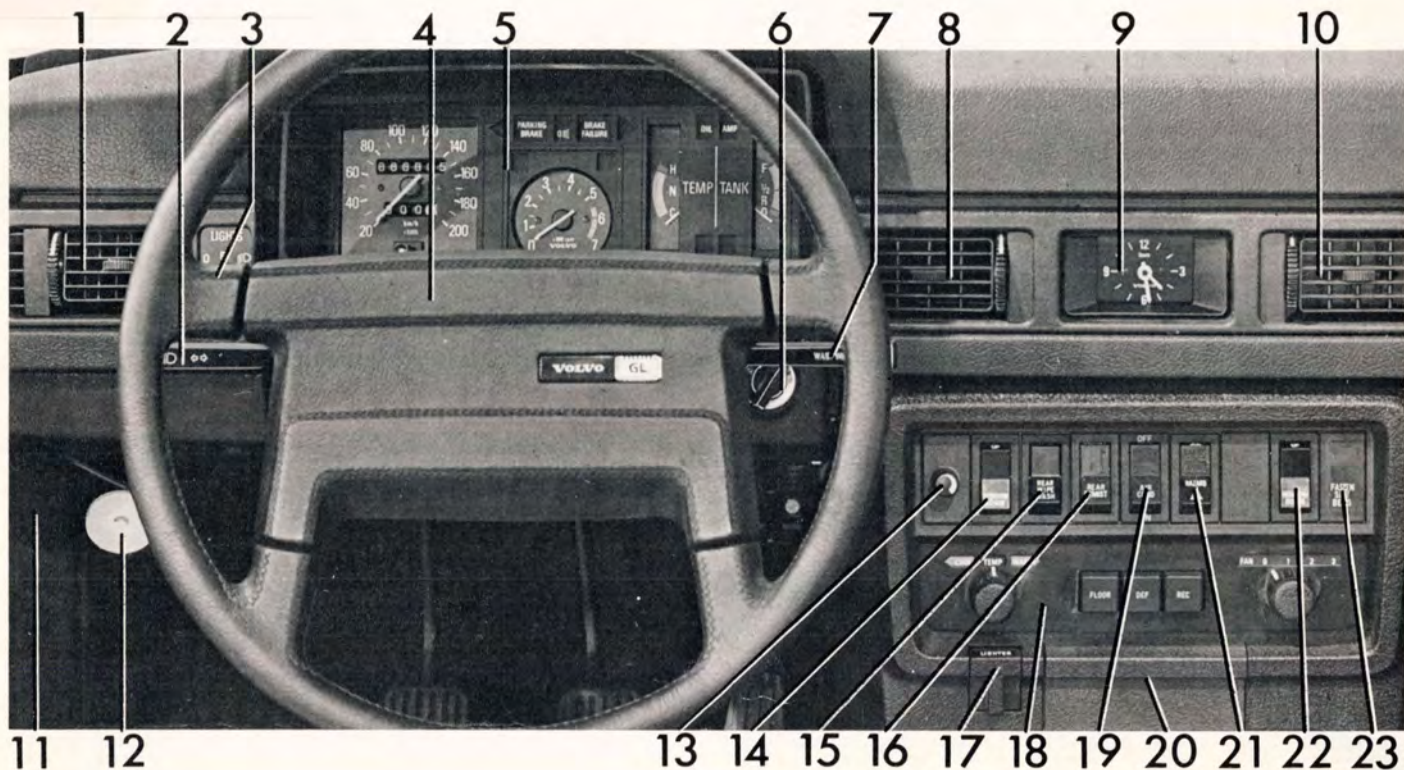

	See page
1 Fresh air outlet	15
2 Turn signals	10
3 Headlights, parking lights	9
4 Horn	—
5 Instruments	6
6 Ignition switch/steering wheel lock	8
7 Wiper washer	11
8 Fresh air outlet	15
9 Clock	12
10 Fresh air outlet	15
11 Fuse box	64
12 Hood release handle	24
13 Instrument lights	9
14 Electrically operated window winder, left front door	12
15 Tail gate window wiper (265)	13
16 Electrically heated rear window	13
17 Cigarette lighter	12
18 Heating and ventilation	14
19 Air conditioning	16
20 Ash tray	12
21 Hazard warning flasher	13
22 Electrically operated window winder, right front door	12
23 Seat belt reminder light	20

Pages 6–16 will give you a detailed description of the vehicle's instruments and controls.

Note that vehicles may be differently equipped, depending on special legal requirements, etc.

Instruments

- A Odometer**
Mile reading
- B Speedometer**
- C Left turn signal indicator (green)**

- D Parking brake reminder light (red)**
- E High beam indicator (blue)**
- F Brake failure warning light (red)**

- G Right turn signal indicator (green)**
- H Oil pressure warning light (red)**
- I Alternator warning light (red)**

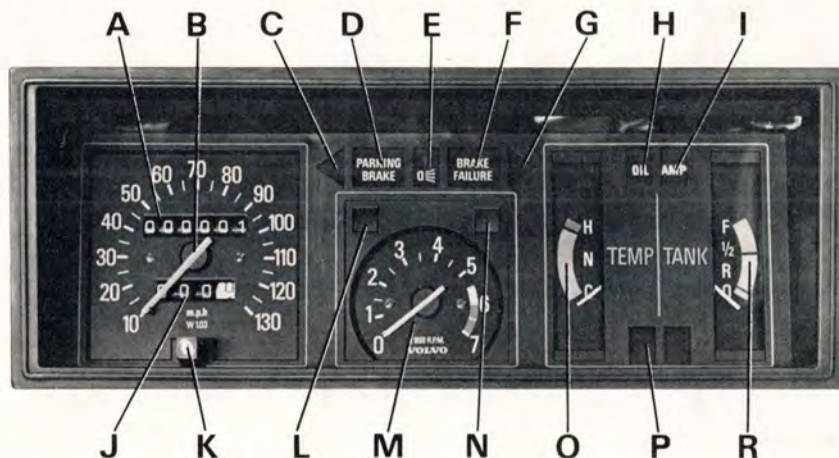

- J Trip odometer**
(last figure represents 1/10 mile)

- K Trip odometer reset knob**
Push in to reset

- L Reminder light, EGR Service**

- M Tachometer (certain models)**
Reads thousands of engine rpm.
Orange range for momentary use, during acceleration.
Red prohibited range.

- N Bulb failure warning light (yellow)**

- O Temperature gauge**
The gauge pointer should normally remain inside the green range.
If the pointer enters the red range repeatedly, check coolant level and fan belt tension, see page 47.

- P Overdrive indicator (green)**
Lights when overdrive is engaged.

- R Fuel gauge**

The fuel tank capacity is approx 60 liters = 15.8 US gals./13.2 Imp. gals.

F Full

1/2

R Reserve

O Empty

The red range from R to O represents approx. 8 liters = 2.5 US gals.12 Imp. gals.

The warning lights described on this page should never be on when driving

When the ignition is turned on, and before the engine starts, all of the warning lights should be on to test the function of the bulbs. Should a light not go off after the engine has started the system indicated should be inspected. (However, the parking brake reminder light will not go off until the parking brake is fully released.)

D Parking brake reminder light (red)



This light will be on when the parking brake (hand brake) is set. The parking brake lever is situated between the front seats.

F Brake failure Warning light (red)



If the light comes on while driving and the brake pedal can be depressed further than normal, it is an indication that one of the brake circuits is not functioning. Proceed cautiously to a Volvo dealer for a check.

H Oil pressure warning light (red)



If the light comes on during driving, the oil pressure is too low. Stop the engine immediately and check the engine oil level, see page 48.

After hard driving, the light will come on occasionally when the engine is idling. This is normal, provided it goes off when the engine speed is increased.

I Alternator warning light (red)



If the light comes on when engine is running, check the alternator drive belt tension as soon as possible. See page 49.

Note: This warning light is illuminated if the alternator drive belt is defective or damaged and the alternator not charging. **However, indicator lights D, F, L and N will be illuminated at the same time** due to the construction of the system.

L Reminder light EGR service (red)



If the vehicle is equipped with an EGR (Exhaust Gas Recirculation) 15000 mile service reminder light, as required by the U.S. Environmental Protection Agency, the light will come on at 15000 mile intervals. This is a reminder to take your Volvo to your Volvo dealer to get the EGR valve serviced. The light will stay on until it is reset by your Volvo dealer.

N Bulb failure warning light (yellow)



The light will come on if any of the following bulbs are defective:

- one of the lower beams
- one of the tail lights
- one of the license plate lights
- one of the brake lights (when the brake pedal is depressed).

Bulb replacement, see page 60–63.

Ignition switch, parking brake

Ignition switch/steering wheel lock



- 0 Locked position:**
remove the key to lock the steering wheel.



- I Intermediate position:**
certain circuits (heater blower, cigarette lighter etc.) on.



- II Driving position:**
key position when engine is running.



- III Starting position:**
release the key when engine starts. The key returns automatically to driving position.

The steering wheel lock might be under tension when the car is parked. Turn the steering wheel slightly to free the ignition key.

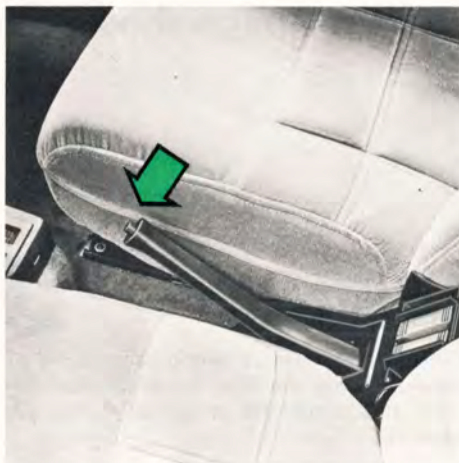

Parking brake (hand brake)

The lever is situated between the front seats. The brake is applied to the rear wheels. In order to obtain the best possible performance of the parking brake, the brake linings should be broken in, see page 39.



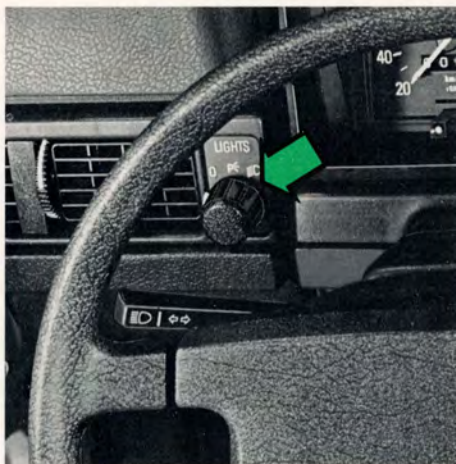

Parking brake reminder light

The reminder light PARKING BRAKE on the instrument panel comes on whenever the parking brake control is not fully released and the ignition is on.



Headlights and parking lights

-  All lights off
-  Parking lights on
-  Headlights and parking lights on

Switch from upper to lower beams, and vice versa, by moving the turn signal switch lever on the left side of the steering column towards the steering wheel. The lights can be used without switching on the ignition key.

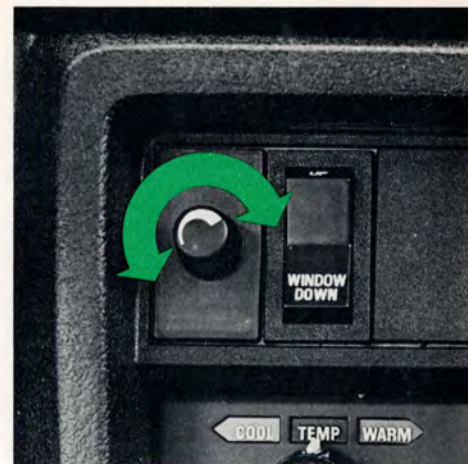

Instrument lights

- Clockwise – brighter.
- Counter-clockwise – dimmer.

Turn signals

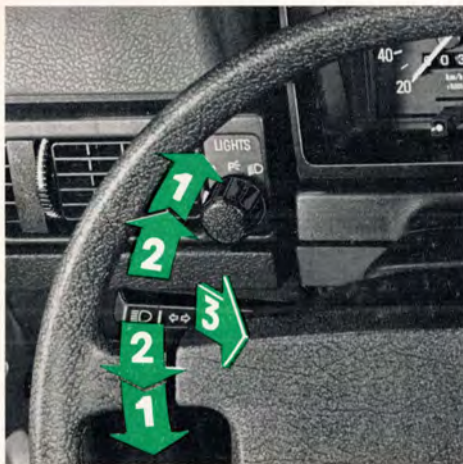

Turn signals

- 1 Signal lever engaged for normal turns.**
- 2 Lane change position.** In maneuvers such as lane changing, the driver can flash the turn signals by moving the turn signal lever to the first stop and holding it there. The lever will return to the neutral position when released.

- 3 High and low beam switching (headlights on)**
Move the lever towards the steering wheel and release it.
- 3 Headlight flasher (headlights off)**
Move the lever towards the steering wheel. The headlight high beam will be on until the lever is released.

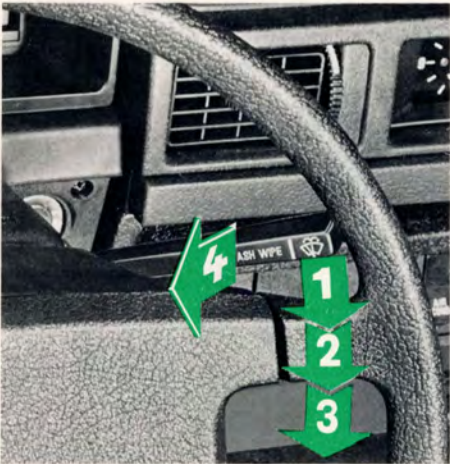

Wiper/washer

- 1 "Single stroke" position.
Switch returns automatically when released.
- 2 Wipers, low speed
- 3 Wipers, high speed
- 4 Washer

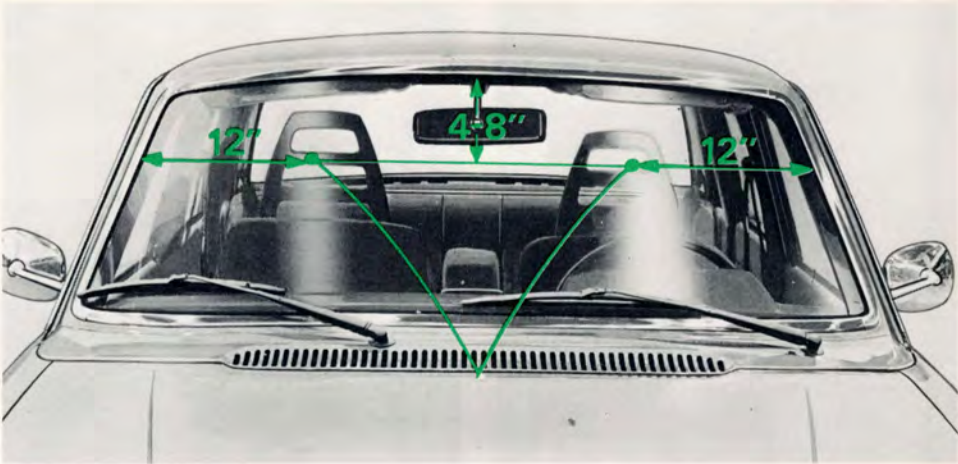

Adjusting washer nozzles

The nozzles may be adjusted by inserting a needle in the metal insert and rotating the nozzle.

The washer fluid reservoir is located in the engine compartment and holds approx. 6 liters = 1.6 US gals./1.3 Imp gals.

Clock, cigarette lighter, ash tray



Clock

To reset the hands, push in the reset knob and turn.

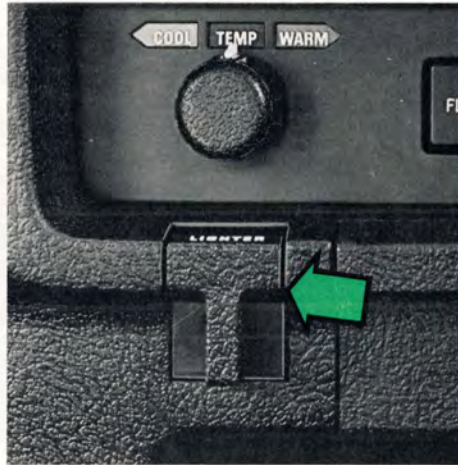

Cigarette lighter

To operate, depress the knob fully. When the knob automatically releases, the cigarette lighter is ready for use.

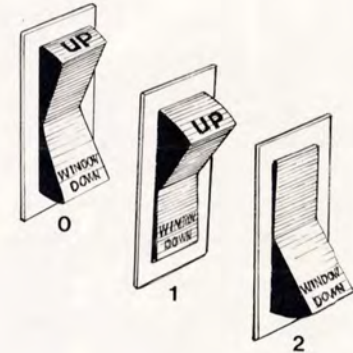

1 Electrically operated window winder (Grand Luxe)

- 0 Off
- 1 Window down
- 2 Window up

Ash trays

To remove the ash trays depress the center spring and remove.

Tailgate window wiper, el. heated rear window, hazard warning flasher



Electrically heated rear window
Hazard warning flashers

2 Tail gate window wiper/washer (model 265)

0 Off

1 Wiper and washer operating.

Move the lever to the first stop and hold it there.

2 Tail gate wiper only.

The fluid reservoir is located in the concealed storage area under the floor on the right side of the rear cargo area. Reservoir capacity is approx. 1.5 qts.

3 Electrically heated rear window

0 Off

1 On

Switch off the heated rear window when the glass is clear of mist or frost. Otherwise the battery will be unduly strained.

Do not place items against the inner surface of the rear window that may damage the printed circuit. Do not scrape the inner surface of the rear window glass with a hard object, otherwise damage to the printed circuit will occur.

4 Hazard warning flasher

0 Off

1 On

Four-way flashing indicates that the vehicle has become a traffic hazard either during daylight or at night.

NOTE: Regulations regarding the use of the hazard warning flasher may vary from state to state.

Heating and ventilation

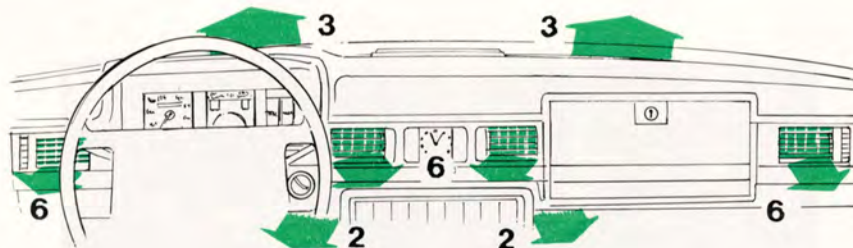

Heating system

1 TEMP

Left = cool
Right = warm

2 FLOOR

Out = no air to floor
In = full flow of air to floor

3 DEF (defrost)

Out = low volume air flow to defroster
In = full flow

4 REC (recirculation)

To be used only for cars equipped with air conditioning.
Do not use for heating

5 FAN (Blower motor)

0 = off
1 = low speed
2 = medium speed
3 = high speed

6 Ventilation outlets

The air flow through the ventilation outlets is not influenced by the position of the FLOOR (2) and DEF (3) controls.

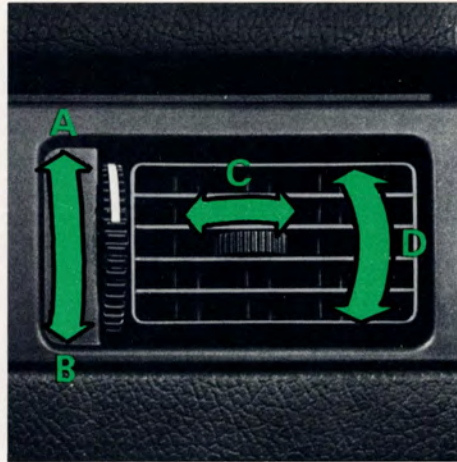

How to ...

... obtain max. heat

- 1 TEMP → WARM
- 2 FLOOR → depressed
- 5 FAN → 2 (or 3)
- 6 All outlets halfway open

... remove condensation

- 1 TEMP → WARM
- 3 DEF → depressed
- 5 FAN → 2 (or 3)

Always keep front external inlet grille (in front of the windshield) clear of obstructions (snow, ice etc.).

Fresh air outlets

- A Closed
- B Open
- C Directing air flow horizontally
- D Directing air flow vertically

Air conditioning



Air conditioning

How to use the air conditioner:

1 FAN

Position 3 for rapid cooling.

The AC does not operate unless FAN is on.

2 AIR COND

Push in the button to start the compressor.

3 REC (Recirculation)

Push in for rapid cooling.

4 TEMP

Rotate to COOL for rapid cooling, then set to desired temperature.

To obtain rapid cooling, all windows must be closed and buttons FLOOR and DEF out.

All the air will then be discharged through the four dash outlets which should be fully open.

NOTE: For rapid removal of condensation from inside glass surfaces, the air conditioner can be switched on even when not required for interior cooling. The air conditioner will dehumidify the air inside the vehicle. Have your Volvo dealer check the system for correct operation yearly.



Low-back support adjustment



Seat back angle adjustment



Horizontal seat adjustment

Front seats

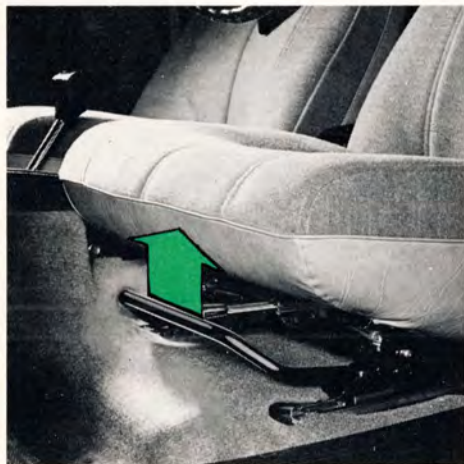

Horizontal seat adjustment



Seat inclination adjustment



Lumbar support adjustment



Seat back release, 2-door models

Press the button and fold forward.

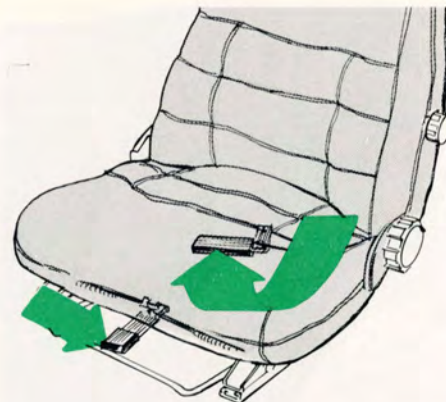

Driver seat height

There are two levers, each with three positions, for adjusting the height of the front or the back of the seat.

This means that the seat cushion angle can be adjusted for comfort.

When adjusting the seat in any position check that it is securely latched.

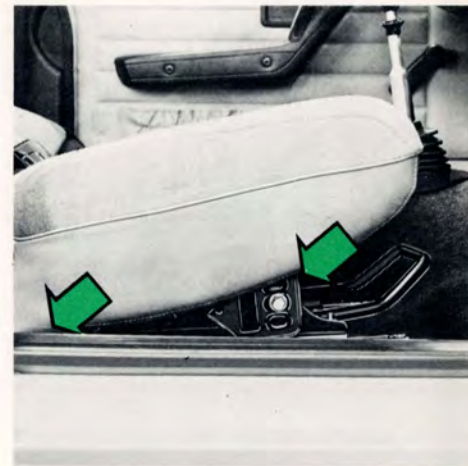

Passenger seat height

The front passenger seat is retained by four brackets, each with three positions. The positions are the same as the driver's seat. However this adjustment must be carried out manually using appropriate hand tools.

Seat belts

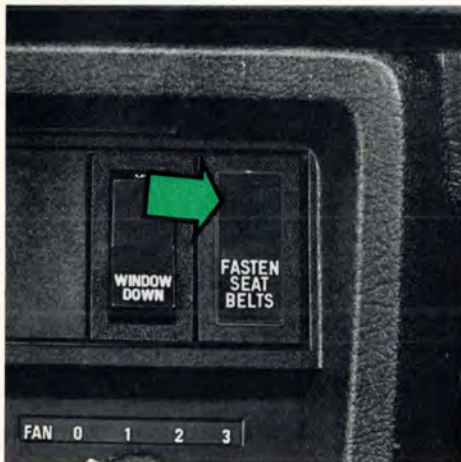

Front seats



Rear seats

Seat belts, retractable

Use the seat belts whenever you drive or ride.

A light on the dash is reminder to buckle the front seat belts.

NOTE: Small children (up to the age of 8–10 years) should not use adult type seat belt. The front seats and the rear outboard seats are provided with retracting inertia belts.

To buckle, pull the belt slowly across your body until the latch plate can be inserted into the buckle with a discernable snap. Take care that the belt does not twist.

To release, depress the red button on the

buckle and let the belt rewind to its rest position.

The seat belts are normally “unlocked” to allow movement while seated. However, the belt will lock and restrict movement:

- if it is pulled out rapidly
- during braking or acceleration
- if the vehicle is leaning excessively
- when driving in turns

Check seat belt mechanism function as follows:

- Attach the seat belt. Pull heavily on the strap.
- Brake hard from approx 30 mph (50 km/h) or drive in a tight circle (check other traffic first!). Pull the belt.

In these cases the belt should not be able to be pulled out.



Seat belts, manually adjustable

The center rear seat belt is a manually adjustable belt. It should always be adjusted to the correct length.

To lengthen: turn the buckle and pull it out, as shown in the picture.



To shorten: pull the upper part of the double webbing.

Maintenance

Check periodically that the bolts are secure and the belt in good condition.

Use water and a detergent for cleaning.

As the seat belts lose much of their strength when exposed to violent stretching, they should be replaced after collision, even though they may appear to be undamaged. Never modify or repair the belt on your own, but have this done by a Volvo workshop.

Doors and locks

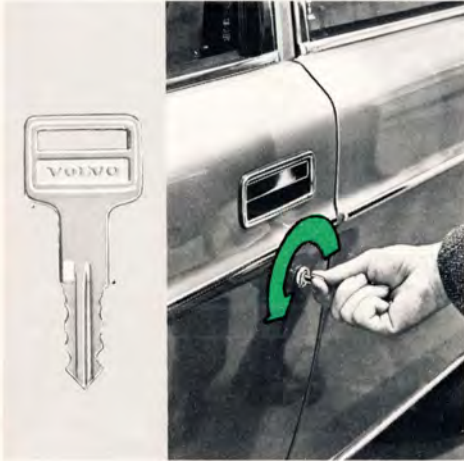

Unlocking front doors

Both front doors can be unlocked by using the key. Turning the key 1/4 turn counter-clockwise lifts the lock buttons on the window ledge and the door can be opened by pulling the handle.

Locking doors

All doors can be locked by depressing the lock buttons. To lock the front doors, press down the lock button and keep the door handle pulled out while shutting the door.

To lock the rear doors, press down the lock button and shut the door. It is not necessary to keep the door handle pulled out.

To open a rear door from inside, the lock button must first be pulled up.

The lock buttons should not be in the down position during driving. In case of an accident, it prevents aid from entering the vehicle.

In wintertime the door locks should be "lubricated" with a suitable agent to prevent freezing. If the lock is frozen, be careful not to break the key in the lock. Thaw the ice by heating the lock or the key.



Child safety locks, 264 and 265

The buttons are located on the rear door jams.

A Normal lock function.

B The door cannot be opened from the inside.



Trunk lid, 262 and 264

To open the lid, turn the knob clockwise.

NOTE: the key must be removed from the lock in order to permit turning of the knob.

The spare wheel, jack and tool kit are stowed on the left side of the trunk.

Hood

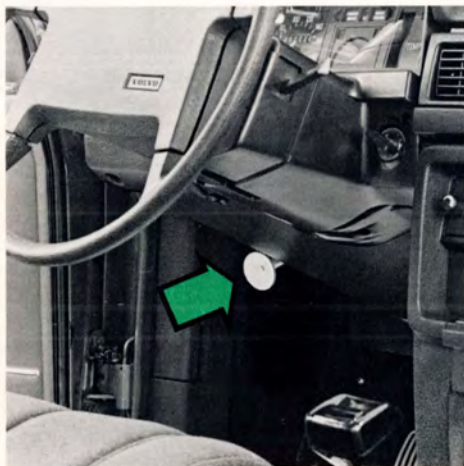

To open the hood

Pull the release handle (located on the left side under the dash).

Lift the hood slightly, insert a hand under the center line of the hood and depress the safety catch handle. Open the hood. Check that the hood locks properly when closing.

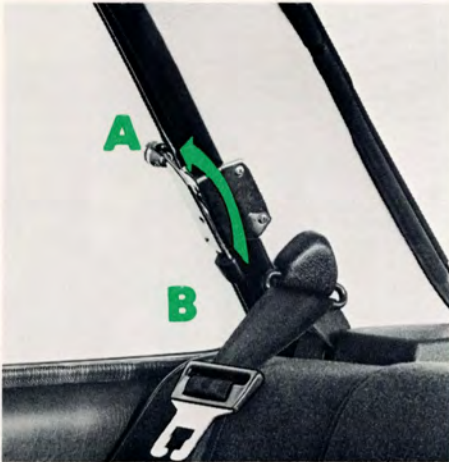

Rear vent windows. 2-door models

- A Open
- B Closed



Outside mirrors

- A Adjustment sideways
- B Adjustment up-down

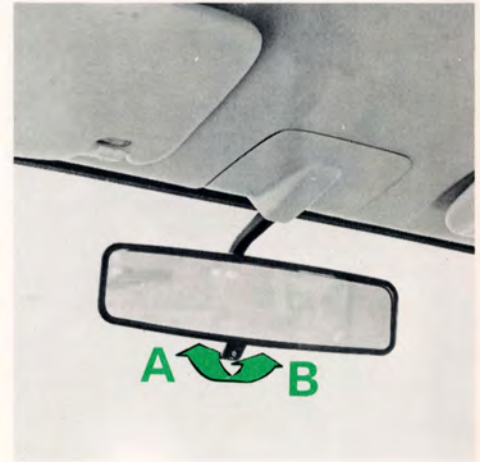

Inside mirror

- A Normal position
- B Night position, reduces glare from following headlights

The mirrors should always be adjusted before driving.

Interior lights, sun roof, fuel tank cap



Interior light

- 1 Light always on
- 2 Light always off.
- 3 Light is on when either of the front doors are opened.

Model 265 may be provided with a light that differs from that in the 262/264.

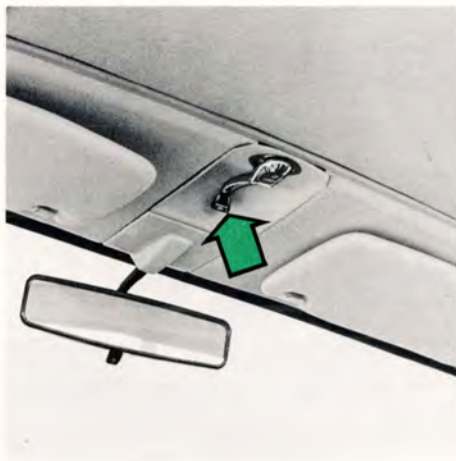

Sun roof (certain models)

The sun roof is operated by a handle located between the sun visors. Unfold the handle and turn it counter-clockwise to open, clockwise to close. For safety reasons, the handle should always be folded when driving.



Filling fuel

The gas cap is located behind the door on the right rear fender. When filling, position the cap in the special bracket on the door.

Note: Unleaded fuel is required for certain models. A label on the instrument panel and rear fender, near the filler inlet will remind owners and filling station attendant of this requirement.

Important! It is unlawful to dispense leaded fuel into any vehicle labeled "unleaded Gasoline only".



Folding rear seat

Depress either lever located at the front bottom edge of the rear seat cushion (right or left side). Tilt the seat towards the front seat.

Pull up on either of the parallel-connected handles on the rear side of the seat back and fold the seat back forward and down so that it lies flat. The rear seat back and cushion are fixed automatically in their respective positions.

When replacing the rear seat to its normal position, make sure the latches are securely locked and the seat belts lie on top of the seat back so they can easily be used.

Model 265, tail gate



To open from the outside

Use the front door key. Depress the release button located under the tail gate handle.



To open from the inside

Pull out the handle at the gate bottom.

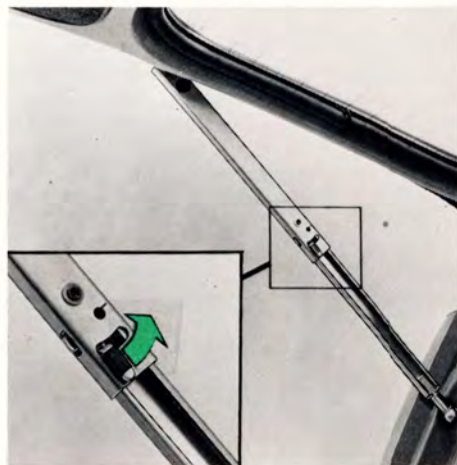

To close

Push the red catch upwards and at the same time lift the gate 1/4 inch. Close the gate slowly but firmly.



Safety catch

- A The lid cannot be opened from the inside.
- B The lock functions normally.



Spare wheel

Remove the two screws and lift off the cover. The spare wheel is now accessible.

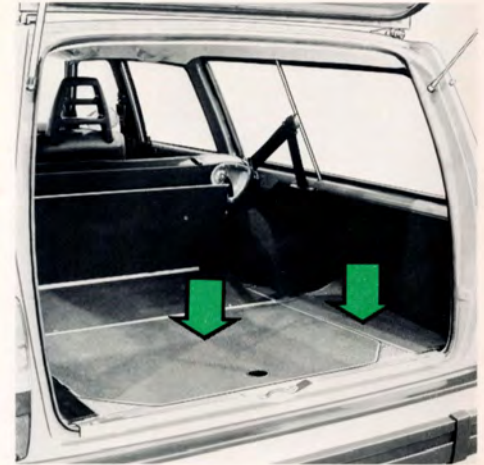

Concealed storage space

There are two concealed stowing places under the cargo compartment floor. The tail gate window washer fluid reservoir and the jack are located in the right one.

STARTING AND DRIVING

Service Inspection

To ensure proper operation the car should be taken to a Volvo dealer after the first 600 miles for a service inspection. The oil in the engine, transmission and rear axle will then be changed. This is very important since the oil rapidly collects impurities during the break-in period.

Every Volvo engine is test-driven prior to delivery. Volvo is therefore assured that all clearances are satisfactory and thus accepts no responsibility for damage caused by careless or harsh driving during the break-in period.

Starting and driving

A new car should be broken in!

During the break-in period do not exceed following speeds:

First 600 miles (1000 km)

1st gear	20 mph	(30 km/h)
2nd gear	30 mph	(50 km/h)
3rd gear	50 mph	(80 km/h)
4th gear	70 mph	(110 km/h) ¹⁾

¹⁾ 80 mile/h (130 km/h) with overdrive engaged.

²⁾ 90 mile/h (150 km/h) with overdrive engaged.

600–1200 miles (1000–2000 km)

1st gear	25 mph	(40 km/h)
2nd gear	45 mph	(70 km/h)
3rd gear	60 mph	(100 km/h)
4th gear	80 mph	(130 km/h) ²⁾

Avoid driving at low speed in high gear. Do not use "kick-down" when driving a car equipped with an automatic transmission during the first 1200 miles.

Starting the engine

To start the engine:

- 1 Enter the car and fasten the seat belt.
- 2 Apply the parking brake, if not already set.
- 3 Place the gear selector lever in neutral.
(Position N or P, automatic transmission).
- 4 Depress the clutch pedal.
- 5 Do not touch the throttle pedal.
- 6 Turn the ignition key to starting position.
Release the key as soon as the engine starts.

If the engine does not start at once, depress the throttle pedal half way and keep it there until the engine starts.

Avoid repeated short attempts to start (fuel is injected every time the starter is engaged). Allow the starter to operate for a longer time (but not more than 15–20 seconds).

Do not race the engine immediately after starting when cold.

Warning

Always open the garage doors fully before starting in a garage. The exhaust gases contain carbon monoxide, which is invisible and odorless but very poisonous.

Engine warm-up – initial driving procedure

Experience shows that engines in vehicles driven short distances are subject to abnormally rapid wear because the engine never reaches normal operating temperature. It is therefore beneficial to reach normal operating temperature as fast as possible. This is achieved by driving with a light load as soon as possible.

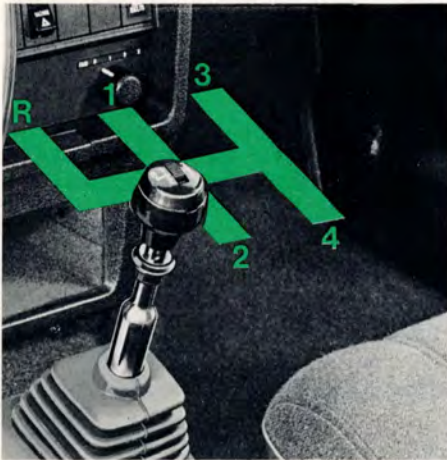

4-speed manual transmission

Depress the clutch fully when changing gears.



Overdrive

The overdrive can be engaged in 4th gear only.

IN engaged
OUT disengaged

No extra operation of clutch or throttle pedal is normally necessary. **Engagement** is facilitated if the accelerator pedal position is maintained steady.

When **disengaging**, depressing the clutch pedal slightly makes a smooth transfer.

Do **not** use the overdrive at speeds below 40 mph (60 km/h).

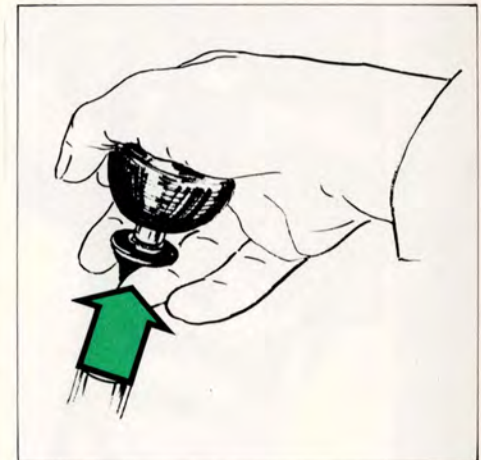

Reversing inhibitor

Lift the ring to enter reverse gear.
The ring locking mechanism prevents reverse gear from being engaged unintentionally.

Automatic transmission



Shift positions

- P park
- R reverse
- N neutral
- D drive
- 2 } low gear
- 1 }

The gear selector can be moved freely between D and 2. The other positions are separated by a lockout which is operated by depressing the selector knob.

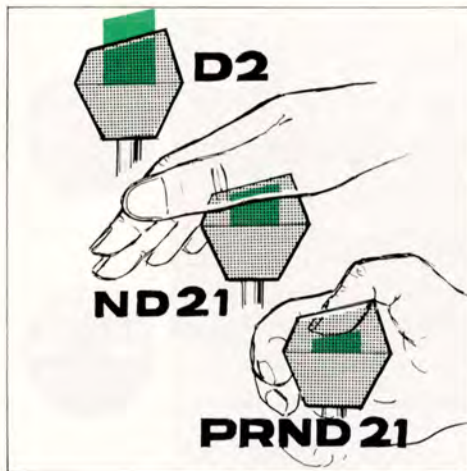

Shift gate

Depressing the selector knob slightly allows selection of positions **N** and **1**.

Depressing the selector knob fully allows selection of positions **R** and **P**. This is also necessary when initially bringing the selector out of position **P**.

Depressing the selector knob fully thus permits shifting freely between all positions.

P Parking

Use this position when parked with the engine running or stopped.

Never use P while car is in motion.

The transmission is mechanically locked in position P. Also use the parking brake when parking on grades.

R Reverse

Never use R while car is in motion.

N Neutral

Neutral position = no gear is engaged.

Driving gears

D Drive

D is the normal driving position. Up- and downshift between the three forward gears occurs automatically and is governed by throttle opening and speed.

2, intermediate position

Up- and downshift automatically between positions 1 and 2. (low and intermediate)

No shift to 3rd gear. (top gear)

Position 2 can be used to obtain immediate downshifting to 2nd gear (increased "engine braking effect").

Position 2 can be used

for relatively slow highway driving

for city driving

when driving on mountain roads where precise speed control is desirable

for passing

to increase the "engine braking effect".

Top speed when selecting 2: 75 mph (125 km/h).

1, low position

If position 1 is selected when driving at high speeds, 2 is engaged first and 1 when the speed has dropped to approx. 30 mph (50 km/h).

NOTE: No upshift once 1 is engaged.

Use position 1 when you want a low gear and no upshift, for instance, when entering and descending steep grades.

Top speed when selecting 1: 75 mph (125 km/h).

Kick-down

By depressing the throttle pedal briskly (passing the normal full throttle position) automatic shift to a lower gear is achieved.

When approaching the top speed for a particular gear or releasing the throttle pedal slightly an up-shift will be achieved.

Kick-down can be used for maximum acceleration, for instance, passing at highway speeds.

Starting and stopping a car equipped with automatic transmission

- 1 Enter the car and fasten the seat belts.
- 2 Apply the parking brake or the brake pedal to hold the car (or the car will start moving when the gear selector is moved).
- 3 Select position **P** or **N**. (Engine cannot be started in any other position).
- 4 Start the engine by turning the ignition key.
- 5 Select desired gear.
- 6 Release the brake and accelerate.

To stop the car, release the throttle pedal and apply the brakes.

It is not necessary to move the gear selector. The transmission will downshift automatically.

Rocking the car

If the car becomes stuck in snow, sand or mud, it can often be moved by a rocking motion. Move the gear selector rhythmically between **D** and **R** while applying slight pressure to the throttle pedal.

NOTE:

- **Never use P or R while the car is in motion.**
- **The engine should be idling when selecting positions D, 2, 1 or R with the car standing still.**
- **Never select positions 2 or 1 at speeds above 75 mph (125 km/h).**

Emergency towing (pulling)



Front eyelet

To the right under the car.



Rear eyelet

To the right, under the car.

Precautionary steps.

To observe when towing

Steering must be unlocked.

Observe legal speeds.

Remember that power brake and power steering assists will not be available when engine is inoperative. Pedal pressure is 3–4 times normal and steering effort increased.

Towing cars equipped with automatic transmission: Gear selector in position N, check transmission oil level (see page 56).

Maximum speed: 20 mph (30 km/h).

Maximum distance: 20 miles (30 km).

THE ENGINE CANNOT BE STARTED BY PUSHING OR PULLING THE CAR.

When jump-starting observe that the booster battery + must be connected to the car battery +. The booster battery– must be connected to the car battery–. Any other connection will damage alternator and electronic components.

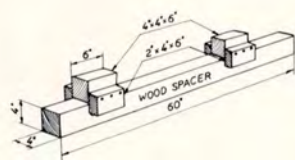

Wood spacer blocks adjustable to conditions

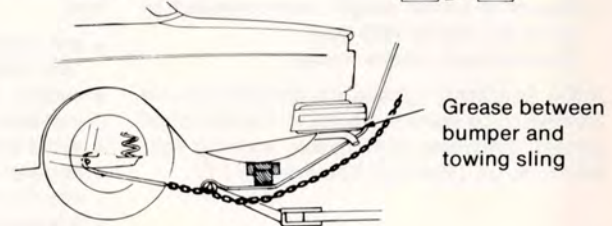
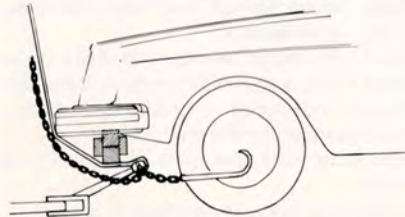
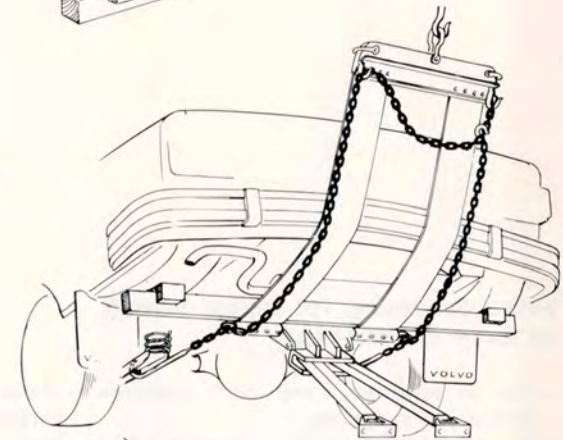
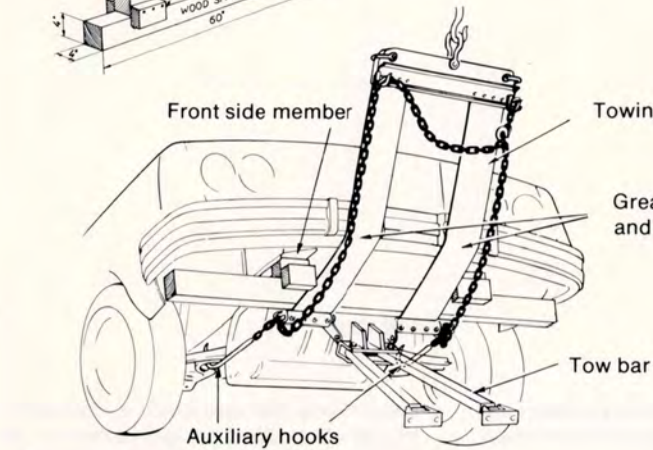
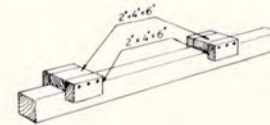

When preparing for trailer towing, observe the following:

- Use an approved trailer hitch (available through Volvo dealers).
- Maximum trailer weight recommended by Volvo is 2 000 lbs (908 kgs). Observe legal requirements.

Note: Additional lighting equipment must be connected to specific points in the electrical system. Otherwise bulb failure warning light will come on. (See your Volvo dealer.)

Trailer hauling does not normally present any particular problems, but take into consideration:

- the hitch tonque load should not exceed 160–200 lbs (75–90 kgs).
- engine and transmission are subject to increased loads
- avoid overload and other abusive operation
- hauling a trailer affects handling, durability and economy
- it is necessary to balance trailer brakes with the towing vehicle brakes to provide a safe stop
- more frequent vehicle maintenance is required.

Roof rack

- Use a strong roof rack which is intended for the vehicle and can be rigidly attached. The Volvo dealers furnish roof racks developed by the Volvo factory.
- Avoid point loads, distribute the load evenly.
- Place heavy cargo at the bottom of the load.
- Observe that center of gravity and handling are influenced by the load weight.
- Increasing load size increases wind resistance.
- Anchor the cargo correctly with a cord.
- Drive smoothly, avoid rapid starts, heavy cornering and heavy braking.
- Max. roof load is 220 lbs (100 kg).

Handling, roadholding

At normal operating load your Volvo has a tendency to understeer. This means that in a curve the steering wheel will have to be turned more to get the same response as the speed increases. This understeer will decrease the chances that the rear wheel will lose traction and slide.

Roadholding is greatly affected by tire pressure. Volvo advises not to experiment with the pressure and instead follow Volvo recommendations.

Volvo also warns against mixing tires of different types, such as bias ply with radial tires, as this will alter the cars handling.

Driving with trunk lid open

Normally this involves no hazard to the passengers. However, exhaust gases can be sucked into the car. As this is especially true for the 265 model always heed the following safety precautions:

- Close the windows.
- Set the heating systems FLOOR and DEF controls to max. and the blower to full speed (3). See page 14.

Moisture on brake discs and brake pads affects braking

Driving in rain and slush or passing through a normal car wash can cause water to collect on the brake discs and pads. This will cause a delay in braking effect when the pedal is depressed. To avoid such a delay, when the brakes are needed, depress the pedal occasionally when driving.

This will remove the water from the brakes. This should also be done after washing or starting in very damp weather.

If the brake power assist does not function

The power assist to the brakes functions only when the engine is running. When the car is moving without the engine running the brake pedal pressure required to stop the car is increased 3–4 times.

The pedal feels stiff and hard.

If one of the brake circuits should malfunction the red warning light comes on, F page 6.

The pedal stroke increases slightly and the pedal feels softer but the pedal pressure required does not increase noticeably.

Drive cautiously to a Volvo dealer or Service Station to have the brake system checked.

Breaking in parking brakes

To obtain best parking brake performance, the brake linings should be broken in.

Stop 5–7 times from 30 mph, transmission in neutral. Apply the parking brake lever, release button pressed in during the stop.

The force must not lock the rear wheels. If this happens, release the brake enough to let the wheels rotate. Drive a mile between each stop to cool the brakes.

NOTE:

The brake lights are not illuminated when applying the parking brake. To warn traffic from behind it is therefore advisable to depress the brake pedal slightly to illuminate the stop lights.

Severe strain on the brake system

The brakes will be subject to severe strain when driving in mountains or hilly areas.

The speed is usually low which means that the cooling of the brake is less efficient than when driving on level roads.

To reduce the strain on the brakes it is advisable not to use the brakes excessively. Instead, shift into a lower gear and let the engine help with the braking. A good rule is to use the same gear downhill as would be used uphill. For vehicles with automatic transmission use position 2 or in some cases 1.

Maintenance Services

Your Volvo has passed two major inspections before it was delivered to you. One was made at the Volvo factory and one was performed by the dealer, according to Volvo specifications. When driven 600 miles your car should be brought to the Volvo dealer who will perform a service inspection; engine, transmission and rear axle oils, for instance, will be changed.

Following this inspection, maintenance inspections as outlined in this book should be performed every 7 500 miles.

The extended maintenance inspection intervals make it even more advisable to follow this program.

Inspection and service should also be performed any time a malfunction is observed or suspected.

Retain receipts for all vehicle emission services to protect your emission warranty.

See your "Warranty and Maintenance Record book".

Maintenance inspection 7 500 miles intervals

Volvo advises you to follow the inspection program of 7500 mile intervals which is outlined in the "Warranty and Maintenance Record Book". This maintenance program contains inspections and services necessary for the proper function of your car over the next 7500 miles.

The maintenance inspections contain several checks which require special instruments and tools and therefore must be performed by a qualified technician.

THE FEDERAL CLEAN AIR ACT (USA)

The Clean Air Act requires vehicle manufacturers to furnish written instructions to the ultimate purchaser to assure the proper functioning of those components that control emissions.

The maintenance instructions listed on pages 44, 45 represent the minimum maintenance required. These services are not covered by the warranty. You will be required to pay for labor and material used. Refer to your "Warranty and Maintenance Record book" for further details.

Gas station checks

Fuel RON 91

Octane rating 91

For vehicles with catalytic converter **unleaded fuel must be used.**

Vehicles not equipped with catalytic converter can use leaded or unleaded fuel (see also page 26).

Engine oil

Maintain oil level between the dipstick marks; the distance between the marks represents 2 quarts (2 liters). Engine oil "For API Service SE" SAE 10 W-40.
See also page 48.

Coolant

Maintain fluid level between MAX and MIN marks on expansion tank.

Mixture of 50 % anti-freeze and 50 % water.

Washer fluid

Washer fluid reservoir.

Water and solvent (wintertime: windshield washer anti-freeze).

Brake fluid Hydraulic clutch

Clutch fluid (only car with manual transmission).

Check, without removing the cap, that the level is above the MIN mark.

Brake fluid DOT 3 or DOT 4 (SAE J 1703).

Battery

Acid level $\frac{1}{4}$ " - $\frac{3}{8}$ " above plates.

Use distilled water only, **never** add acid.

Warning: battery gases are explosive.

Engine B27 F

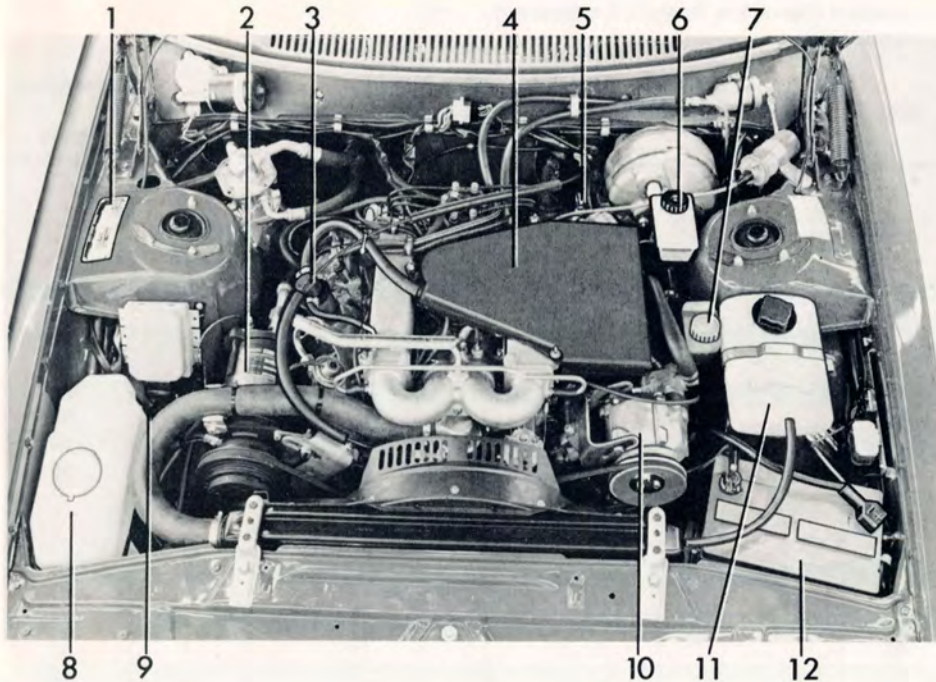

- 1 Data plate
- 2 Compressor (Air conditioner)
- 3 Oil filler cap, engine
- 4 Air cleaner
- 5 Oil dipstick, automatic transmission
- 6 Brake fluid reservoir
- 7 Oil reservoir, power steering
- 8 Washer fluid reservoir
- 9 Oil dipstick engine
- 10 Air Injection Reactor Pump
- 11 Expansion tank
- 12 Battery

Servicing

A = Adjust (Correct if necessary)
R = Replace

I = Inspect (Correct or Replace if necessary)
L = Lubricate

Maintenance Operation	Miles	600	7,500	15,000	22,500	30,000	37,500	45,000	Description on page
EMISSION CONTROL SYSTEM									
I ENGINE MECHANICAL COMPONENTS									
Engine Oil*		R	R	R	R	R	R	R	48
Engine Oil Filter*		R	R	R	R	R	R	R	48
Engine Coolant						R			49
Cooling System Hoses and Connections				I		I		I	49
Engine Drive Belts		A	I	I	I	I	I	I	49
Torque Manifold Bolts		A							50
Valve Clearance				I		I		I	50
Vacuum Fittings, Hoses and Connections		I		I		I		I	50
II ENGINE FUEL SYSTEM									
Fuel (Line) Filter						R			51
Fuel (Tank) Filter				I		I		I	51
Air Cleaner Filter						R			51
Idle RPM		A		I		I		I	52
Mixture Ratio and Manifold Balance		I		I		I		I	52
Fuel System Cap, Tank, Lines and Connections		I				I			52
Fuel Injection Electrical Connections				I		I		I	52

* Oil and oil filter cartridge are first changed at the 600 mile inspection. Subsequent oil and filter changes should be made at 7,500 mile intervals or **at least twice a year**.

However, adverse conditions (like hot ambient temperatures, trailer pulling, hill climbing, driving long distances at high speeds, extended periods of idling or low speed operation, short trip operation at freezing temperatures) require oil changes more frequently (every three months).

Maintenance Operation	Miles	600	7,500	15,000	22,500	30,000	37,500	45,000	Description on page
III ENGINE IGNITION COMPONENTS									
Spark Plugs (see also page 52)				R		R		R	52
Distributor Advance Mechanism						I			52
Ignition Timing				I		I		I	52
Distributor Cap and Rotor				I		I		I	52
Ignition Wiring				I		I		I	52
IV ENGINE CRANKCASE VENTILATION SYSTEM									
PCV Nipple (Orifice)				I		I		I	53
Ventilation Hoses				I		I		I	53
Oil Filter Breather Cap and Flame Arrester				I		I		I	53
V ENGINE EXTERNAL EMISSIONS									
Exhaust Gas Recirculation Components**				**I		**R		**I	53
Throttle Valve Switch				I		I		I	53
Air Injection Reactor System				I		I		I	54
Catalytic converter mounting bolts	A			A		A		A	55
VI ENGINE EVAPORATIVE EMISSIONS									
Evaporative Control Filter								R	55

** EGR valve is cleaned at 15,000 & 45,000-mile intervals and is replaced every 30,000 miles.

Servicing

MAINTENANCE SCHEDULE

A = Adjust (Correct if necessary)

R = Replace

I = Inspect (Correct or Replace if necessary)

L = Lubricate

Maintenance operation	Miles	500	7,500	15,000	22,500	30,000	37,500	45,000	on page
DRIVETRAIN									
Manual Transmission Oil		R	I	I	I	R	I	I	56
Automatic Transmission Oil		I	I	I	I	1*	I	I	56
Rear Axle Oil		R	I	I	I	I	I	I	57
BRAKES									
Inspect Brakes			I			I		I	
Change Brake Fluid								R	57
STEERING									
Tire War (align Front End if needed)		I	I	I	I	I	I	I	65
Check Power Steering Fluid Level		I	I	I	I	I	I	I	57
BODY									
Trunk Door and Hood Hinges and Latches		L	L	L	L	L	L	L	58

* For cars used for hard driving, or in hilly terrain, etc. preventive service including oil change should be carried out every 30,000 miles.

The following items should be checked weekly by the driver.
This only takes a few moments.

Description
on
page

The following should also be carried out at regular intervals.

Description
on
page

Engine oil level

48

Washing

68

Brake fluid

57

Polishing

68

Radiator coolant level

59

Cleaning

69

Battery water level

42

Rust protection

69

Tire pressure, all five tires

85

Operation of all lights

Horns

Windshield wipers

Level of windshield fluid

Engine oil

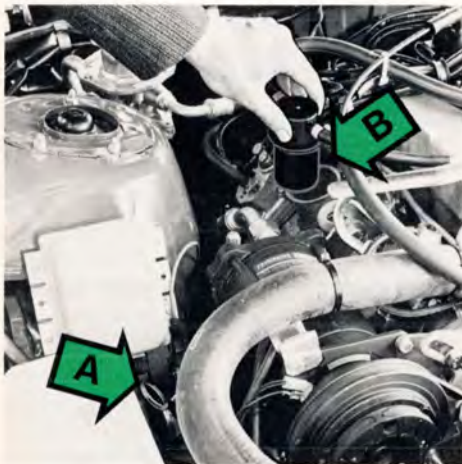

A oil dipstick B oil filler hole

Checking oil level

The oil level should be checked each time the fuel tank is refilled. Be sure the oil level is maintained between the upper and lower marks on the dipstick. Low oil level can cause internal damage to the engine and overfilling can result in high oil consumption. The distance between the dipstick marks represents 2 quarts of oil.

To add or change oil

Capacity: 6.8 US qts/5.7 Imp. qts incl. filter.

Oil type: API Service SE classification.

Viscosity:

All year round { SAE 10W-40
SAE 10W-30
SAE 10W-50

Above +14°F
(-10°C) SAE 20W-50

Replace: At 600 miles and every 7500 miles
(or at least **twice a year**).

At temperatures below 0°F multigrade oil SAE 5W-20 is recommended. However, this oil should not be used when the temperature is continuously above 32°F.

Driving under adverse conditions such as high ambient temperatures, trailer pulling, hill climbing, driving long distances at high speeds, extended periods of idling or low speed operation, short trip operation at freezing temperatures, may require oil and filter changes more frequently (every three months).

Drain the oil after driving while it is still hot.



Changing oil filter

Replace the oil filter at every oil change. If the oil filter is changed separately, 1/2 qt. of oil should be added.

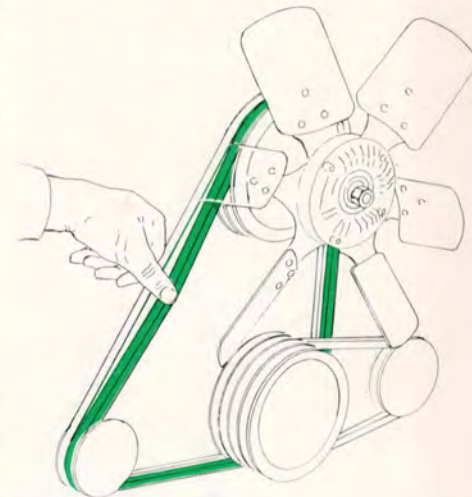
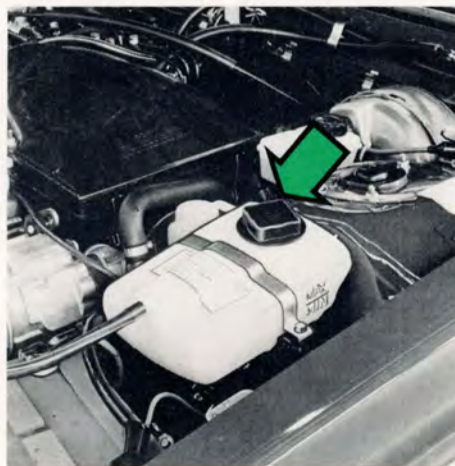
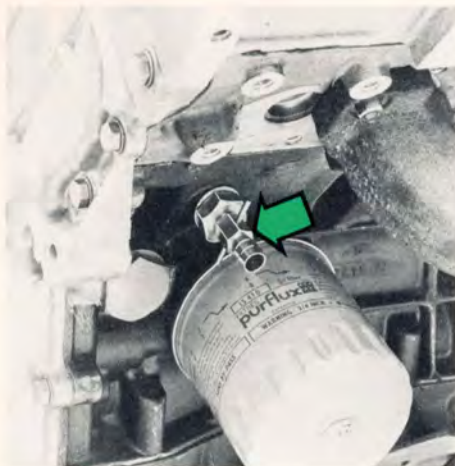

Changing coolant

Every two years or 30 000 miles the cooling system should be drained, flushed and re-filled.

Remove the expansion tank cap.

Open the drain cocks on both sides of the engine block and disconnect the lower radiator hose.

Fill coolant through the expansion tank.

The heater controls should be fully open when draining and filling.

Add coolant until the level is up to the MAX mark or slightly above.

Start engine and run until hot. Check the cooling system for tightness. Also re-check the coolant level.

Capacity: 11.5 qts/9.6 Imp. qts.

Cooling system, hoses and connections

Check all cooling system hoses and connections for defects or deterioration of hoses and loose clamps or fittings.

Drive belts

The belt tension can be checked by depressing the fan belt at a point midway between the alternator and fan. It should be possible to press down the belt about $\frac{1}{4}$ " – $\frac{3}{8}$ " (5 – 10 mm). This also applies to other drive belts on the engine.

I Engine mechanical components

Torque manifold bolts

The manifold bolts should be torqued at the 600 mile inspection. A loose manifold could alter air/fuel ratio and cause an increase in emissions and/or poor driveability.

Valves

The valve clearance should be checked every 15 000 miles.

Vacuum fittings, hoses and connections

Unstable idle, misfiring or poor emission control is often caused by leaking vacuum hoses or connections. Check hoses and connections on distributor vacuum unit, EGR valve and connections heater control servo systems and hydraulic brake servo.

II Engine fuel system

Ci— System

The B27F engine is provided with a fuel injection system called the CI-system (Continuous Injection), which means that the injectors are open and inject fuel as long as the engine is operating.

This system has few moving parts, is reliable and copes with the exhaust emission standards.

Air supplied to the engine is continuously measured and determines the amount of fuel injected.

The air flow is regulated by two throttles.

The air flow sensor and the fuel distributor are integrally built as a single unit. A lever is actuated by the air flow to produce continuous fuel distribution.

Fuel

91 octane RON (Research Octane Number). Unleaded fuel permitted for all models and **required** for certain models (with catalytic converter).

A label on the instrument panel and on the rear fender, near the filler inlet will remind of this requirement.

It is unlawful to dispense leaded fuel into a vehicle labeled "unleaded gasoline only".

Special instructions for work on the fuel injection system

Extreme cleanliness is essential when working on the injection system. Great care must be observed.

Injection system service should be handled by authorized Volvo dealers, using equipment intended for this service.

Fuel (line) filter

The fuel filter is located on the firewall. This filter is to be changed every 30 000 miles. The filter is replaced as one complete unit. Filter replacement should be made in a shop.

Fuel (tank) filter

A filter is installed in the suction line in the fuel tank. Its function is to prevent any dirt in the tank from being sucked up to the fuel pump. The filter should be cleaned every 15 000 miles.

Air cleaner

Replace the air cleaner cartridge with a new one every 30 000 miles. The cartridge should be replaced more often when driving under dirty and dusty conditions. No cleaning of any kind is to be made between the above mentioned intervals.

Emission Control Systems

Checking and adjusting idling speed and mixture ratio and manifold balance

These checks should be made every 15 000 miles. The idling speed should also be adjusted and the mixture ratio and manifold balance checked at the 600 miles inspection.

Fuel system cap, tank and lines, and connections

The effectiveness of the fuel system to contain hydrocarbons is largely dependent on a leak-free system. Check for proper sealing of gasoline filler cap which contains "O" ring type seals. Check all evaporative hoses in vehicle for tightness. Check fuel lines under vehicle and repair if necessary.

Inspection of fuel injection electrical connections

The electrical connections and fuel lines in the injection system should be checked for chafing and corrosion every 15 000 miles.

III Engine Ignition Components

Change spark plugs

The spark plugs should be changed every 15 000 miles.

However, city driving or fast highway cruising require changing after 7 500 miles of driving. Tightening should be done with a torque wrench. When fitting new plugs, be sure to fit the right type (Champion BN 9 Y or corresponding).

When changing the plugs, check that the suppressor connectors are in good condition. Cracked or damaged connectors should be replaced.

When changing spark plugs, clean the cables and cable terminals, also the rubber seals. If the car is driven on roads where salt has been placed to counteract skidding, spray the cables with silicone spray.

Ignition timing Distributor advance mechanism

The ignition timing should be adjusted every 15 000 miles. All adjusting work should be done with the proper equipment. The distributor is one of the most sensitive engine units. Careless handling can lead to decreased engine output and high fuel consumption or even serious damage to the engine.

The distributor advance mechanism should be checked every 30 000 miles.

Ignition wiring

Ignition wiring system is composed of primary and secondary systems. The secondary systems are the high tension leads connecting the distributor cap with the spark plugs and the coil.

These wires should be inspected at each engine tune-up, and should be replaced if cracked, frayed or damaged from abrasion. It is important to clean all parts of this secondary system thoroughly because dirt greatly reduces the available voltage to the spark plugs.

Distributor cap and rotor

Check the distributor cap and rotor for cracks, carbon formation, dirt and erosion.

IV Engine crankcase Ventilation System

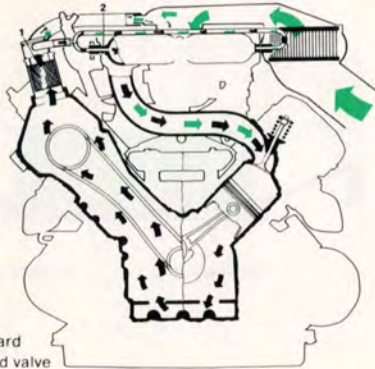

- 1 Flameguard
- 2 Calibrated valve

Crankcase ventilation

The engine is provided with positive crankcase ventilation which prevents crankcase gases from being released into the atmosphere. Instead the crankcase gases are admitted to the intake manifold and cylinders.

Cleaning PVC valve

The calibrated positive crankcase ventilation valve should be removed and cleaned every 15 000 miles. Rubber hoses and flame guard should be checked for damages at the same time. Replace if necessary.

V Engine External Exhaust Emissions

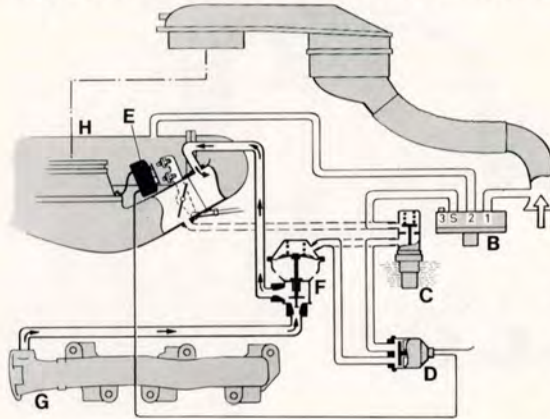

- B Vacuum amplifier (some models)
- C Thermostat
- D Solenoid valve (some models)
- E Micro switch (some models)
- F EGR valve
- G Exhaust manifold
- H Intake manifold

Exhaust Gas Recirculation Components

Clean EGR valve and manifold nipple every 15 000 miles.

Replace EGR valve every 30 000 miles.

To remind the driver about the EGR service, there is a special EGR service reminder light (see page 7) which comes on at 15 000 miles intervals.

This is a reminder to get the EGR valve serviced. The light will stay on until reset.

Emission Control Systems

- 1 Air pump
- 2 Diverter valve
- 3 Backfire valve
- 4 Air manifold

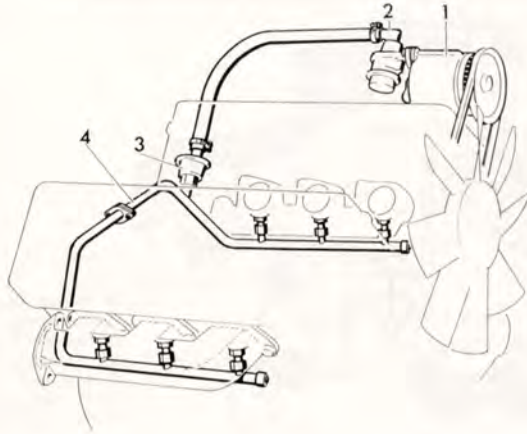

Air Injection Reactor System

This system admits fresh air to the hot exhaust gases in the exhaust manifold. The fresh air will burn the unburned portion of the exhaust gases to reduce hydrocarbon and carbon monoxide contents.

The air pump is located at the engine front and driven by a belt.

The air is drawn into the air pump via an air filter. The compressed air is fed out of the pump through the diverter valve. This valve has two functions. It regulates the air pump pressure. It also shuts off the air delivery when using the engine to brake. If the system was allowed to operate under this condition, fresh air mixed with the overly rich vapor would

cause a backfire.

The backfire valve admits air into the exhaust manifold but prevents return of exhaust gas to the air pump in case of a backfire or air pump malfunction, such as drive belt damage.

Air Injection Reactor check

This system should be checked every 15 000 miles. Hoses and connections should be checked for leaks and condition. Check the diverter valve and backfire valve operation. Check the operation of the air pump and that there is no excessive noise.

The exhaust emissions will be incorrect if the AIR System does not operate properly.

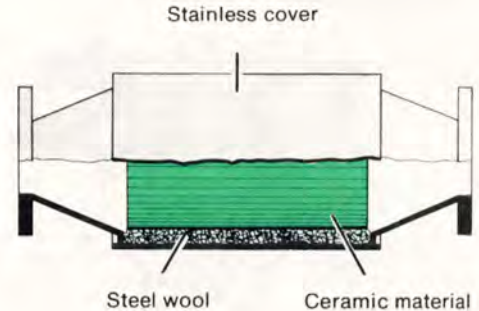

Catalytic Converter

This is a supplementary device in the exhaust system, designed to clean up the remaining dirty exhaust gases.

This device is mainly a container with a ceramic material insert, designed to let the exhaust gases pass through channels in the insert. The channel walls are covered by a thin layer of platina-palladium. These metals act as catalysts, permitting a chemical process without actually taking part of it.

The CO content will increase if the Catalytic Converter is damaged.

VI Engine Evaporative Emissions

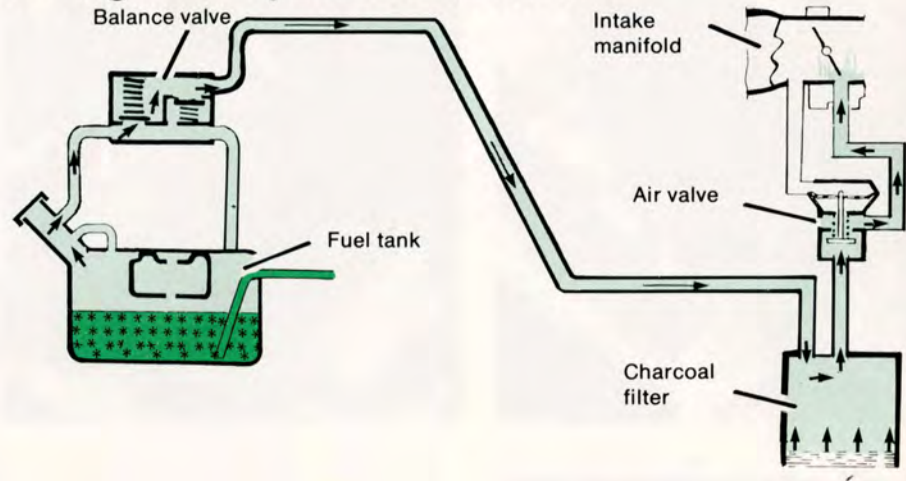

NOTE:

Vehicle with Catalytic Converter must use unleaded fuel only. Otherwise the Catalytic Converter will be destroyed.

Torque Catalytic Converter mounting bolts (certain models)

The Catalytic Converter mounting bolts should be torqued every 15 000 miles.

Evaporative Control Systems

Vehicles intended for the North American market are equipped with a gas evaporative control system, which prevents gas fumes from being released into the atmosphere.

The system comprises an expansion tank in the fuel tank, a check valve at the fuel tank and a charcoal filter in the engine compartment. The components are interconnected by hoses which convey fuel fumes from the gas tank to the charcoal filter where they are stored until the engine is started and then drawn into the engine.

Evaporative Control Filter

Replace the filter every 45000 miles.

Transmission oil

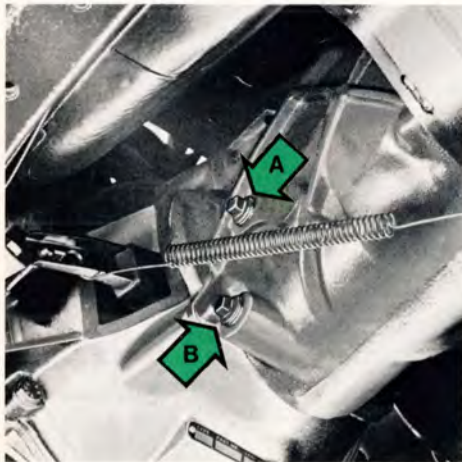

Manual 4-speed transmission with overdrive, M46

Capacity: 2.4 US qt = 2.3 liters

Oil type: API GL-1

Viscosity: SAE 80 W/90 or SAE 80/90

Replace: at 600 miles and every 30 000 miles.

The oil level should be up to the filler plug (A).

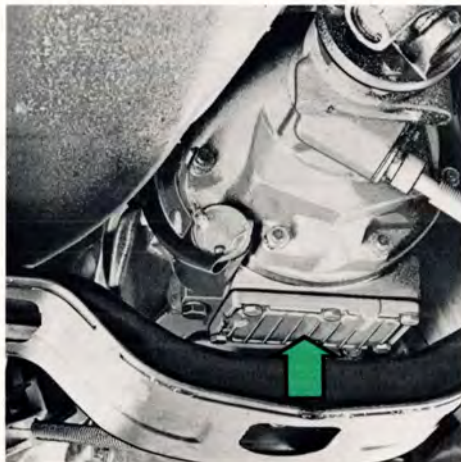

Transmission and overdrive are lubricated by the same oil. Therefore, when the oil is drained through plug B, also remove cover on the overdrive and clean strainer.

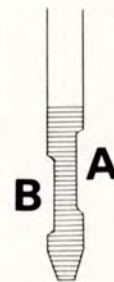

Automatic transmission, BW55

Capacity: 5.8 US qts = 5.5 liters

Fluid type: Automatic Transmission Fluid, type F (FLM)

Replace: no oil changes necessary under normal driving conditions.

When checking fluid level the car should be on level ground, in PARK position with the engine idling. If topping up is necessary, fill through the dipstick tube.

NOTE: the dipstick has graduations for hot (A) and cold (B) transmission fluid. When checking the fluid level use a clean rag that will not leave lint.

Rear axle, power steering, brake fluid



Rear axle

Capacity: 1.7 US qts = 1.6 liters
Oil type: API GL-5
Viscosity: SAE 90
Replace: at 600 miles only

The oil level should be up to the filler plug (A).
Drain rear axle oil through drain plug (B).
When the temperature is steadily below
15°F = -10°C, use API GL-5 SAE 80 W oil.
Cars equipped with limited slip differentials
should use oils with proper additives.



Power steering

Capacity: 1.25 US qts = 1.2 liters
Fluid type: ATF
Replace: no fluid change required.

The level should be between the MAX and
MIN marks on the container.

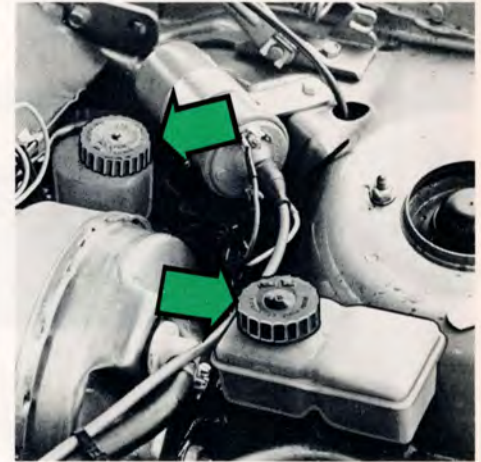

Brake fluid

Clutch fluid (only on cars with manual transmission)

Fluid type: DOT 3 or DOT 4 (SAE J 1703)
Replace: every third year or 45 000 miles.
The clutch fluid does not need to
be changed.

Check, without removing the cap, that the
level is above the "MIN" mark of the fluid
reservoirs.

Always entrust brake fluid changing to a
Volvo dealer.

Change brake fluid every year when driving
under extremely hard conditions: mountain
driving etc.

Lubrication

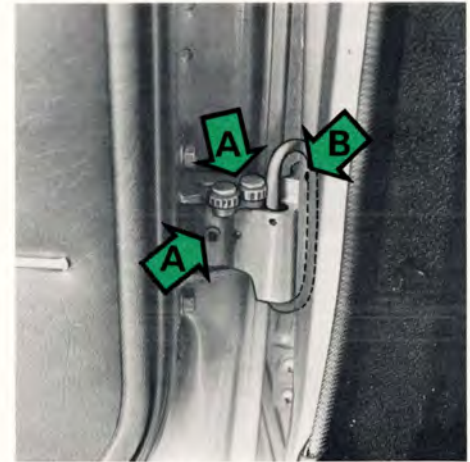
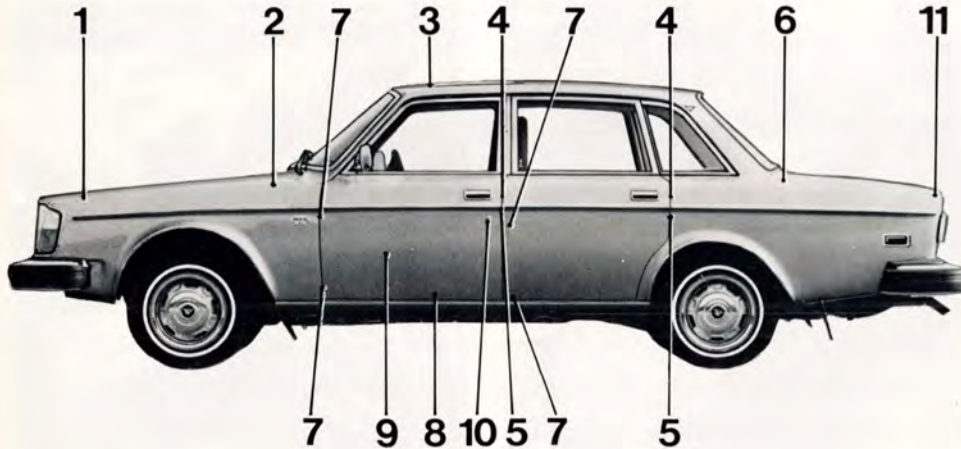

A grease B oil

Chassis maintenance

To simplify maintenance of your Volvo, the vehicle has been equipped with ball joints, steering rods and propeller shafts that do not require regular lubrication.

Points that normally require lubricating have been packed with very durable grease at the factory and then carefully sealed, eliminating the need for subsequent lubrication.

Lubricate body

To avoid rattle and unnecessary wear, the body should be lubricated once a year. Hinges on hood, doors and trunk lid as well as door stops should be lubricated every 7500 miles.

During wintertime, locks in the doors and trunk lid should be treated with special anti-freeze lubricant to prevent freezing.

No. Lubricating point	Lubricant
1 Hood lock	Paraffin wax
2 Hood hinges	Oil
3 Sun-roof wind deflector	Oil
4 Door lock outer sliding surfaces	Paraffin wax
5 Striker plate	Paraffin wax
6 Trunk lid hinges	Oil
7 Door hinges (upper)	Grease
Door hinges + Door stops (lower)	Grease, oil
8 Front seat slide rails and latch devices	Oil
9 Window regulator Locking device (accessible after door upholstery panels removed)	Oil, grease Silicon grease
10 Key holes	Lock oil
11 Trunk lid lock	Lock oil

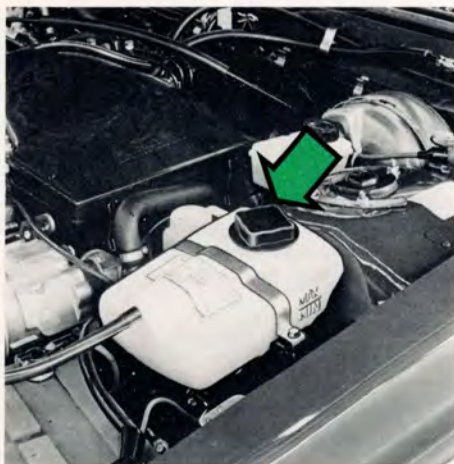

Check coolant level

The cooling system must be filled with coolant and not leak to operate at maximum efficiency. Check the coolant level when filling fuel. The level should be between the "Max." and "Min" marks on the expansion tank. The check should be made with particular thoroughness when the engine is new or the cooling system has been drained.

Do not remove the filler cap other than for topping-up with coolant. Frequent removal may prevent coolant circulation between the engine and the expansion tank during engine warming up and cooling.

Top up with coolant

Top up with coolant by filling the expansion tank when level is at the "Min" mark. Use a mixture of 50 % anti-freeze/summer coolant and 50 % water all the year round. Top up to the "Max" mark.

If the engine is warm, and you are going to top up coolant, unscrew the cap slowly in order to allow any excess pressure to escape.

NOTE: Do not top up with water only. Water by itself reduces both the rust-protective and anti-freeze qualities of the coolant. It can also cause damage to the cooling system if ice should form in the expansion tank.

NOTE: In warm climates where there is little risk of frost, water can be used without anti-freeze.

We recommend, however, to add a rust inhibitor.

Note

This car is equipped with an alternator

When changing the battery or when carrying out work involving the electrical system, the following should be observed:

- 1 A battery connection to the wrong terminal will damage the diodes. Before connections are made, check the polarity of the battery with a voltmeter.
- 2 If booster batteries are used for starting, they must be properly connected to prevent the diodes from being damaged.
The ground lead from the booster battery must be connected to the ground terminal of the car battery and the positive lead from the booster battery to the positive terminal.
- 3 If a fast charger is used for charging the battery, the battery leads should be disconnected.
- 4 Never disconnect the battery circuit (for example, to change the battery) while the engine is running, as this will immediately ruin the alternator.
Always make sure that all the battery connections are properly tightened.
- 5 If any electrical welding work is made on the vehicle, the ground lead and all the connecting cables of the alternator must be disconnected and the welder wires placed as near the welding point as possible.

Replacing bulbs

The replacement of bulbs in the various lighting units is shown on the following pages. Make sure when installing bulbs that the guide pin on the socket fits into its corresponding recess.

When installing bulbs, do not touch the glass with your fingers. The reason for this is that grease, oil or any other impurities can be carbonized onto the bulb and damage the reflector.

Replacing bulbs for instrument lighting and heater control lighting

Due to the location of these bulbs, their replacement should be carried out by a Volvo dealer.

Replacing bulbs for side marker lights

Remove the two Phillips screws which hold the lens. The bulb can now be removed by pressing it inwards and turning it slightly counter-clockwise.

Replacing sealed beam headlamp units

- 1 Press the two plastic screws down and turn them $\frac{1}{4}$ turn and remove them.
- 2 Lift up the rim slightly and remove it forwards.
- 3 Remove clip and rim. Lift out the headlamp unit.
- 4 Disconnect the socket contact.

Installation is done in the opposite way.

Check headlight alignment.

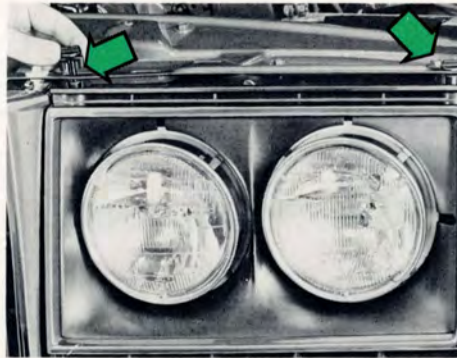

1



2



3



4

Replacing bulbs

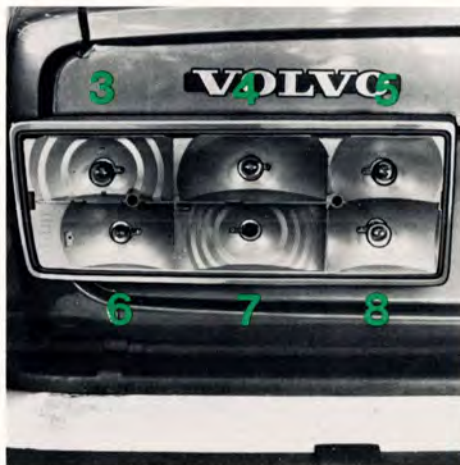

Bulbs

		Power W/cp	Socket	US Bulb No
1	Front position, side marker lights	262, 264, 265	5/4	Ba 15 s 67
2	Front turn signal	262, 264, 265	21/32	Ba 15 s 1073
3	Rear turn signal	262, 264	21/32	Ba 15 s 1073
4	Back up light	262, 264	21/32	Ba 15 s 1073
5	Stop light	262, 264	21/32	Ba 15 s 1073
6	Tail light	262, 264	5/4	Ba 15 s 67
7	Reflector	262, 264	—	—
8	Stop light	262, 264	21/32	Ba 15 s 1073
9	Rear turn signal	265	21/32	Ba 15 s 1073
10	Back up light	265	21/32	Ba 15 s 1073
11	Stop light	265	21/32	Ba 15 s 1073
12	Tail light	265	5/4	Ba 15 s 67

Replacing bulbs

The front bulbs and rear bulbs (265)

Remove the Phillips screws retaining the lenses. Replace bulb by slightly depressing and turning counter-clockwise.

The rear bulbs on 262 and 264

Remove the board wall lining on the inside of the rear wall of the trunk. Unscrew the two plastic nuts securing the light glass. Replace bulb by slightly depressing and turning counter-clockwise.

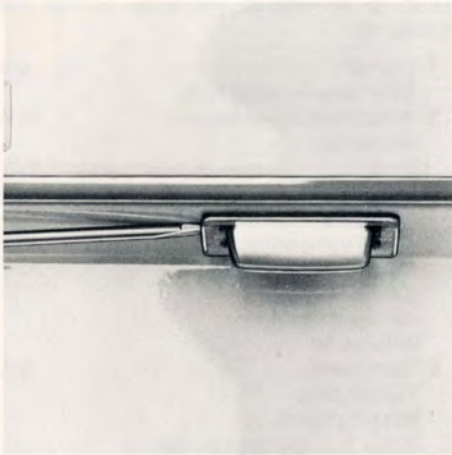

License plate light

Insert a screwdriver through the opening in the housing and depress the catch tab.
Pull out the housing assembly.

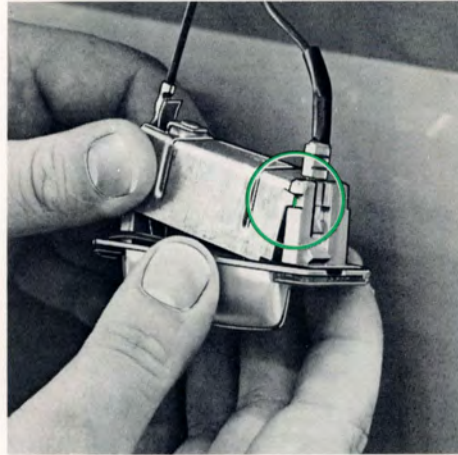

Pull out the cover end which is not provided with a lock pin.
Replace bulb.
When re-installing, first locate the lock pins (see picture) and then press on the cover.
Check that the rubber gasket is positioned and press the housing assembly into place.



Interior light

Insert a screwdriver through the opening in the right side of the housing and depress the catch tab. Pull out the housing assembly and replace the bulb.

Fuses



Replacing fuses

The fuse box is positioned in front of the front left door pillar.

The cover is removed by turning the small knob at the bottom a 1/4 turn.

When replacing fuses, check that right amperage is used.

Never use fuses of higher amperage. If one fuse often melts, take the car to your Volvo dealer for fault-tracing.



Reading downwards the fuses protect the following:

1	Lighter	8 A
2	Rear wiper/washer (265)	16 A
3	Windshield wiper/washer	16 A
4	Heater fan	
5	Horn	
6	Rear demist	16 A
7	Overdrive	
8	Glove compartment light	8 A
9	Back up lights	
10	(El. heated seat)	
11	Air conditioning	
12	Window lift	
13	Instrument	8 A
14	Turn signals	
15	Warning lights	
16	Relay, fuel injection system	
17	(Seat belt warning)	
18	Hazard	8 A
19	Engine compartment light	
20	Trunk light	
21	Rear interior light (265)	
22	Clock	16 A
23	Fuel pump	
24	Stop lights	8 A
25	Interior light	
26	Spare	8 A
27	Window lift	16 A
28	Left parking and side marker light	8 A
29	License plate light, left	
30	Right park and side marker lights	8 A
31	License plate, right	
32	Instrument and panel lights	
33	Seat belt light	
34	Ash tray light	
35	Shift positions light	

General

Your Volvo is equipped with pressed steel wheels and radial tires as standard equipment. The wheel is centered on the hub by means of a centering shoulder and (5) conical wheel nuts. If the wheel is removed, care must be taken to properly center it on the hub before the nuts are tightened.

Snow tires

Studded snow tires require a running-in period of 300–600 miles. During this period avoid any hard cornering, acceleration or braking.

Radial snow tires, with or without studs, are recommended for winter use.

Tire **chains** can be used on the rear wheels only providing that the chains are **finelinked** and do not project so much from the tire that they can chafe against the brake caliper or other components.

Strap-on emergency chains must not be used since the space between the brake calipers and wheel rims does not allow sufficient clearance.

Check tire wear pattern

Check the tires at regular intervals for damage and abnormal wear or foreign particles in the tread which may cause damage. Out of balance wheels increase tire wear and reduce riding comfort.

Always use a radial tire on the same side of the car throughout its lifetime.

Tire wear indicator

The tires have a so-called "wear indicator" in the form of a number of narrow strips running across or parallel to the tread. When about $\frac{1}{16}$ " 1.5 mm is left on the tread, these strips show up and warn the car owner that the tire should be replaced.

Check tire pressure

Check tire pressure at regular intervals to avoid abnormal wear. The spare tire should also be checked to ensure proper inflation when needed. Refer to page 85 for correct tire pressures.

Tire pressures should be checked when the tire is cool (before driving) as the pressure will increase after driving due to heat build up in the tire. When the tires are warm, a change in pressure should take place only when air must be pumped into the tires.

Too little pressure, is the most common reason for abnormal tread wear. Tires which are underinflated will also cause high fuel consumption, heavy steering and poor road holding. Overinflated tires will result in poor riding comfort.

Wheel changing



Changing a wheel

Spare wheel, jack and tool kit are stowed in the trunk compartment. Before raising the car with the jack be sure it is on firm and level ground:

NOTE: Do not creep under the car while it is raised by the jack.

Before the car is raised with the jack the parking brake should be applied and first gear or "P" parking position should be engaged. Block one of the wheels on the opposite side of the car from the jack.

Removing

The wheel cap can be removed with the tommy bar or the screwdriver provided in the tool kit.

Loosen the wheel nuts $\frac{1}{2}$ – 1 turn with the box wrench provided in the tool kit. All of the wheel nuts have right-hand threads which are loosened by turning them counter-clockwise.

Insert the lifting arm of the jack into the jack attachment closest to the wheel to be changed.

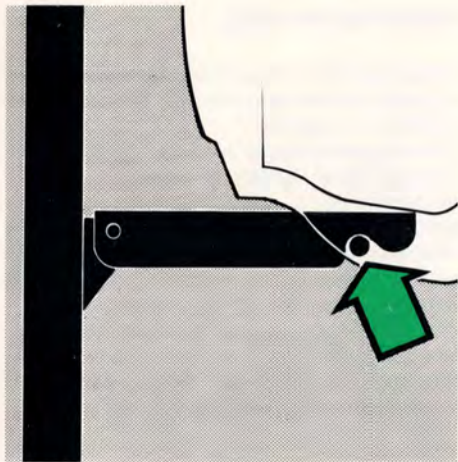

Be sure the arm goes all the way into the attachment.

Raise up the side of the car enough to lift the wheel off the ground.

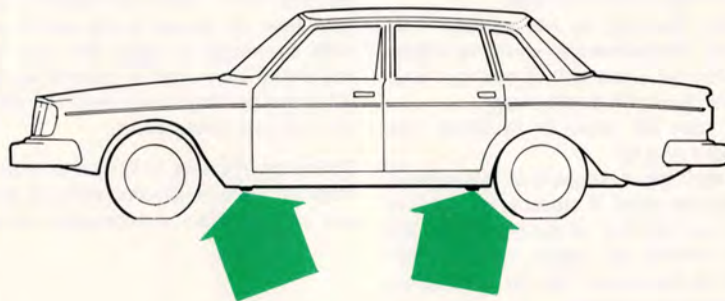

Unscrew the wheel nuts completely and remove the wheel carefully so as not to damage the threads of the studs.

Installation

- Clean the contact surface between wheel and hub.
- Lift on the wheel and fit the wheel center on the hub shoulder.
- Tighten the nuts until the wheel makes good contact with the flange.
- Lower the car and tighten the nuts alternately to 72–100 lb.ft.
- Fit the wheel cap.

NOTE: Do not rotate a raised rear wheel if the car is equipped with a limited slip differential. This will also move the opposite wheel on the ground and cause the car to rock on the jack.

Washing, cleaning

Washing

The car should be washed often as dirt, dust, insects, tar spots etc adhere firmly to the paintwork and may cause damage.

When washing the car, do not expose it to direct sunlight. Use lukewarm water to soften the dirt before you wash with a sponge, and plenty of water, to avoid scratching.

A detergent can be used to facilitate the softening of dirt and oil.

Special car washing detergent or household detergent can be used. A suitable mixture is about 2.5 fl. oz (8.5 cl) of detergent to 2.6 US gal. (10 liters) of warm water. After washing with a detergent the car should be well rinsed with clean water.

A water soluble grease solvent may be used in cases of sticky dirt. However, use a wash-place equipped with a drainage separator.

Dry the car with a clean chamois and remember to clean the drain holes in the doors and rocker panels.

Tar spots can be removed with kerosene or Tar Remover after the car has been washed.

NOTE: It is particularly important to wash the car frequently in the winter time, to prevent corrosion, when salt has been used on the roads.

NOTE: When the car is driven immediately after being washed, brake the car now and again in order to remove any moisture from the brake linings.

Chromed parts

Chromium-plated and anodized parts should be washed with clean water as soon as they become dirty. This is particularly important if you drive on gravel roads which are treated with chemicals to keep the dust down or in the winter when salt is used to melt the snow. After the car has been washed, apply wax or an anti-rust preparation.

Stains on chrome trim can be removed with commercially available chrome cleaner. Do not use abrasive compounds or steel wool.

Polishing (waxing)

Polishing and waxing are not necessary unless a glossy surface can no longer be obtained by normal car washing.

Normally polishing is not required during the first year after delivery, however, waxing may be beneficial.

Before applying polish or wax the car must be washed and dried. Tar spots can be removed with kerosene or tar remover. Difficult spots may require a fine rubbing compound.

After polishing use liquid or paste wax.

Several commercially available products contain both polish and wax. Waxing alone does not substitute for polishing of a dull surface.

Cleaning the upholstery

Generally the **fabric** can be cleaned with soapy water or a detergent. For more difficult spots caused by oil, icecream, shoe polish, grease etc. use a stain remover.

The **Plastic** in the upholstery can be washed. **Leather upholstery** can be cleaned with a damp cloth, eventually with a mild soap solution.

For more difficult spots, consult an expert for the choice of cleaning agent.

On no account must gasoline, naphtha or similar cleaning agents be used on the plastic or the leather since these can damage the plastic and leather.

Cleaning floor mats

The floor mats should be vacuumed or brushed clean regularly, especially during the winter when they should be taken out for drying.

Spots on textile mats can be removed with a mild detergent.

Anti-rust treatment

Your Volvo has been rust protected at the factory. On external surfaces a heavy coat of wear resistant material has been used, while on the internal surfaces a lighter rust protector is used.

The external rust protection should be inspected regularly or at least once per year. If the rust protection has been penetrated a repair should be made as soon as possible to prevent moisture from creeping between the metal and coating. Carefully clean and remove any rust prior to repair of the rust protective coating.

The internal rust protection should normally be renewed after three years and every two years thereafter.

Paint touch-up

Paint touch-up

Paint damage requires immediate attention to avoid rusting. Make it a habit to check the finish regularly and touch-up if necessary, for instance when washing the car.

Paint repairs require special equipment and skill and you should contact your Volvo dealer for any extensive damages.

Minor scratches can be repaired by using Volvo touch-up paint.

NOTE: Use the paint code which you will find on the Vehicle Designation Plate on the wheel housing when ordering touch-up paint from your Volvo dealer.

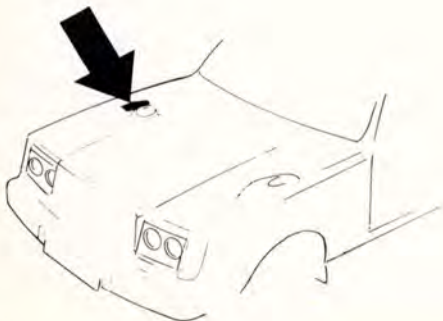

Minor stone chips and scratches

Material:

Rust remover

Primer—brush on type

Surface finish—brush on type

(the paint pen head also contains grinding paste for subsequent treatment)

Penknife or similar

Brush

NOTE! When touching-up, the car should be well cleaned and dry and have a temperature above +15°C (60°F).

Scars on the surface where the paint has not been completely penetrated, can be made directly after light scraping to remove dirt.

Deep scars, down to the bare metal:

NOTE: The vehicle should be well cleaned, dry and have a temperature exceeding 60°F.

- 1 Scrape or sand the damaged surface lightly and break the edges of the scar.

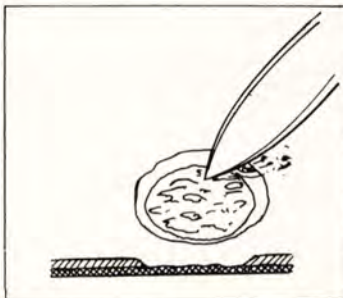

- 2 Apply the rust remover (watch eyes and skin!), wait a few minutes and then rinse carefully with water.
- 3 Thoroughly mix the primer and apply it with a small brush or a match.

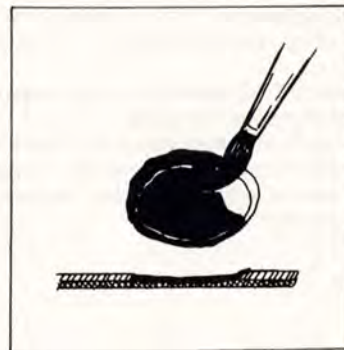

- 4 When the primer surface is dry, the paint can be applied by a brush. Mix the paint thoroughly, apply several thin paint coats and let flush after each application.

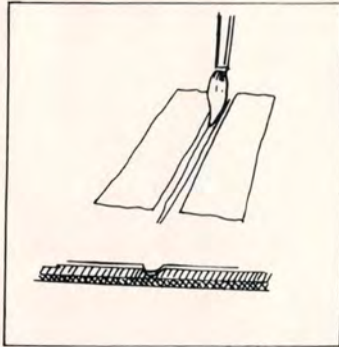

Touching-up flaking fender edges and sills

Material:
Rust remover
Primer – spray
Surface finish – spray
Sand paper (H 150 – 300 grit)
Thinner

NOTE! When touching-up the car, it should be well cleaned and dry and have a temperature exceeding +15°C (60°F).

Mask with tape and paper prior to painting larger surfaces. Remove the masking immediately after application of the last paint coat, before the paint starts to dry.

Touching-up is as follows:

- 1 Remove the flakes.
- 2 Sand the damaged surface and wash it clean with thinner.
Apply the rust remover (watch eyes and skin!), wait a few minutes and then rinse carefully with water.
- 3 Shake the spray can for at least 1 minute.
Spray on the primer. Move the can slowly and evenly forwards and backwards over the spot and about 20–30 cm (8–12 in.) from the surface. Protect the surrounding surfaces with suitable paper.

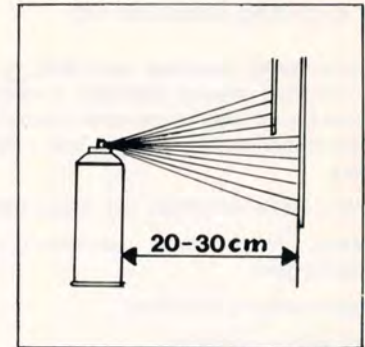

- 5 If there is a longer scratch, you may want to mask to protect surrounding paint.

- 4 When the primer has dried apply the surface enamel in the same way. Spray on several times and allow the paint to dry a minute or so between each application.

Long distance trip

Prior to a long distance trip

Have your Volvo serviced according to the Volvo specified service intervals. Preventive maintenance will help to ensure a trouble free trip. Remember to take along a Volvo dealer directory.

The main items to check are listed below:

- 1 Brakes, front wheel alignment and steering gear.
- 2 Engine running condition.
- 3 Fuel system operation.
- 4 Oil leaks: engine, transmission, rear axle.
- 5 Cooling system for leaks or doubtful hoses.
- 6 Examine tires carefully, replace worn tires.
- 7 Battery and terminals.
- 8 Tool equipment.
- 9 Lighting.
- 10 Drive belts, tightness and wear.

Engine cooling system

A good quality anti-freeze/summer coolant should be used all the year round. Thus, the cooling system should always contain water plus anti-freeze and rust inhibitor, even during the summer. Experience has also shown that extremely weak anti-freeze solutions (10–25%) are very unfavorable rust protection. For this reason, the quantity of anti-freeze/summer coolant should amount to about 50% of the solution that is 5.0 qts = 4.3 Imp. qts = 4.8 liters, thus lowering the freezing point to -31°F (-35°C).

Alcohol must not be used as an anti-freeze agent since it evaporates at normal engine temperature.

Engine fuel system

During the wintertime with large variations in temperature, condensation forms in the fuel tank and can impair the running of the engine.

This can be eliminated by adding special additives to the fuel. There is less risk of condensation forming in the fuel tank if it is kept full.

Engine lubricating system

During the winter multigrade oil 10 W/40 should be used in the engine. At very low temperatures (below 0°F) multigrade oil SAE 5 W-20 is recommended. These oils reach the lubricating points in the engine more easily at low temperature and also facilitate cold starting. See page 48.

Electrical system

The electrical system is subject to great stresses during the winter. Lighting and starter motor are used more. The battery capacity is impaired at low air temperature. The state of charge must be checked more frequently, and if necessary the battery should be charged. The battery may freeze if the voltage is low.

Brake system

During cold weather the brakes are subject to splash and condensation which can result in the parking brake freezing if applied for long periods of time. Use of first or reverse gear on a manual transmission or position "P" on an automatic transmission is preferable during these conditions. See also page 39.

Windshield washers

Just as anti-freeze is added to the cooling system during the winter to prevent frost damage, anti-freeze should also be added to the water container for the windshield (rear window) washer.

This is particularly important during the winter because the windshield frequently becomes dirty and is often splashed with water which rapidly freezes and thus necessitates the frequent use of the windshield washer and wipers. Your Volvo dealer can supply you with suitable anti-freeze for this purpose.

Anti-freeze for door locks

Lubricate the outside locks with a suitable anti-freeze. Such agents are commercially available and should be used before the first frost.

The diagnosis outlined below is only intended to serve as a guide to locate and temporarily correct minor faults. Causes for unsatisfactory performance should be investigated and corrected by your Volvo dealer.

NOTE: The points indicated by an asterisk "*" should be checked by your Volvo dealer.

Condition: Starter fails to operate (or operates very slowly)

Possible cause	Correction
Weak battery or dead cell.	With the ignition switch in the "Driving" or "On" position, check to see if the warning lights on the dashboard come on and if they go off when the starter is engaged. If the lights do not come on or if they go off when the starter is engaged, the battery is discharged or see below.
Loose or corroded battery cable terminals.	Check battery terminals and clamps, clean or replace if necessary. Check that the starter cable is tightened. The ground strap, which connects the body to the rear of the engine, should also be checked for corrosion and looseness.
Open circuit between ignition/starter switch and ignition terminal on starter.	The circuit is closed if a clicking sound is heard from the starter when it is engaged. If no clicking sound is heard, check that the blue wire at the starter is tightened. If still no clicking sound is heard, the ignition switch or the wire is defective.
Starter motor defective.	If the above checks have been performed, and no fault is evident, the starter may be defective.
	NOTE: In this case the headlight intensity will not dim when the starter is engaged.

Service diagnosis

Condition: Starter motor operates but engine does not start

Possible cause	Correction
Intake system leaking.	Check hose connections to cold start valve and auxiliary air valve.
No fuel reaching engine.	Check for fuel in the tank. Check fuse No 7.
No spark.	Remove one spark plug wire and unscrew the radio interference suppressor. Hold the wire approx. $\frac{3}{16}$ " from the valve cover and run the starter. If there is no spark, check: that the high tension lead from the coil to the distributor cap is connected and that the wires to the distributor and coil are connected.
Spark plugs, high tension leads or distributor cap worn (defective).	Clean the parts with a dry cloth or spray with a moisture remover.
Cold start injector out of order.	Test the cold start injector function at cold and hot engine.*
Rest pressure incorrect.	Test rest pressure and the fuel system for leaks.*
	If no fault is found, according to above, see a Volvo Dealer.

Condition: Erratic idle (misfiring)

Possible cause	Correction
Intake system leaking.	Check hose connections to cold start valve and auxiliary air valve.
Exhaust Gas Recirculation Valve leaking.	Test the valve function.*
Spark plugs, high tension leads or distributor cap worn (defective).	Clean cap and leads, check the cap for cracks.
Worn spark plugs.	Remove, clean or replace spark plugs.
Cold start injector leaking.	Test the injector function.*
Uneven compression.	Test compression.*

Condition: Engine stalls at irregular intervals

Possible cause	Correction
Defective wires.	Check wire terminals at: fuel pump, fuse No. 7, coil, distributor, ignition switch, relays and air flow sensor.
Intake system leaking.	Check hose connections to cold start valve and auxiliary air valve.
Low idle.	Adjust.*
Exhaust Gas Recirculation Valve seizing.	Replace valve.* (Engine will die on idle.)
Fuel filter clogged.	Clean fuel tank filter and replace line fuel filter.

Service diagnosis

Condition: Low top speed, loss of power

Possible cause	Correction
Air filter clogged.	Check air filter.*
Throttle misadjusted.	Check that the throttle touches the high speed stop when the accelerator is fully depressed.*
Incorrect timing or dwell angle.	Check and adjust.*
Fuel filter clogged.	Clean fuel tank filter and replace fuel line filter.*

Condition: Excessive fuel consumption

Possible cause	Correction
Fuel lines leaking.	Check tightness.
Spark plugs worn.	Replace plugs.
Incorrect timing.	Check/adjust.*
Air filter clogged.	Check/replace.*
Control pressure incorrect.	Check/replace control pressure regulator.*
Cold start injector leaking.	Replace injector.* (A leaking cold start injector also causes uneven idle and hard starting.)

Condition: Dieseling

Possible cause	Correction
Injector leaking.	Check air sensor plate and rest pressure.*

Condition: Misfiring at highway driving

Possible cause	Correction
Spark plugs fouled.	Drive the vehicle in a lower gear and keep the engine rpm's higher for a few miles in order to remove carbon deposit on the spark plugs. If this procedure is not effective clean or replace the spark plugs if necessary.

Condition: Deceleration backfiring

Possible cause	Correction
Diverter valve faulty.	Check diverter valve operation.*

Dimensions and weights

	262	264	265
Length	192.6" (489 cm)	192.6" (489 cm)	192.6" (489 cm)
Width	67.3" (171 cm)	67.3" (171 cm)	67.3" (171 cm)
Height, curb weight	56.5" (144 cm)	56.5" (144 cm)	57.5" (146 cm)
Wheelbase	104.0" (264 cm)	104.0" (264 cm)	104.0" (264 cm)
Ground clearance (full load)	4.9" (12.5 cm)	4.9" (12.5 cm)	
Track, front	55.9" (142 cm)	55.9" (142 cm)	55.9" (142 cm)
rear	53.1" (135 cm)	53.1" (135 cm)	53.1" (135 cm)
Turning circle (between curbs)	32.5' (9.8 m)	32.5' (9.8 m)	32.5' (9.8 m)
Curb weight (depending on type)	3140–3180 lbs (1425–1440 kg)	3160–3225 lbs (1435–1465 kg)	3260–3305 lbs (1480–1500 kg)
Gross vehicle weight (GVW)	4190 lbs (1900 kg)	4190 lbs (1900 kg)	4300 lbs (1950 kg)
Capacity weight	920 lbs	920 lbs	990 lbs
Permissible axle weight, front	2050 lbs (930 kg)	2050 lbs (930 kg)	2050 lbs (930 kg)
rear	2180 lbs (990 kg)	2180 lbs (990 kg)	2600 lbs (1180 kg)
Max. trailer weight	2000 lbs (908 kg)	2000 lbs (908 kg)	2000 lbs (908 kg)
Max. hitch load	160–200 lbs (75–90 kg)	160–200 lbs (75–90 kg)	160–200 lbs (75–90 kg)

Cargo space

	265
Length with rear seat up	44.5" (113 cm)
Length with rear seat down	74.0" (188 cm)
Maximum width	42.4" (133 cm)
Height	33.0" (84 cm)
Volume with rear seat up	53.0 cu.ft. (1.5 m ³)
Volume with rear seat down	67.0 cu.ft. (1.9 m ³)
Cargo opening, maximum width	45.7" (116 cm)
Cargo opening, maximum height	30.7" (78 cm)

Capacities

Fuel tank	15.8 US galls./13.2 Imp. galls 60 liters
Cooling system	11.5 US qts/9.6 Imp. qts (10.9 liters)
Oil capacity,	
engine, at oil change	6.8 US qts./5.7 Imp. qts. (6.5 liters)
incl. oil filter	6.3 US qts./5.3 Imp. qts. (6.0 liters)
transmission (M45)	0.8 US qts./0.7 Imp. qts. (0.75 liters)
(M46)	2.4 US qts./2.2 Imp. qts. (2.3 liters)
(BW55)	5.8 US qts/4.9 Imp. qts. (5.5 liters)
rear axle	1.7 US qts./1.4 Imp. qts. (1.6 liters)
steering gear, power	1.15 US qts/1.0 Imp. qts. (1.1 liters)

Specifications

ENGINE

Fluid-cooled, gasoline, 6-cylinder V-engine with 90° angle. Aluminium cylinder block with cast iron, replaceable wet liners. Aluminum cylinder head has separate inlet and exhaust passages. Single, overhead camshafts.

Engine oiling provided by a gear pump driven from crankshaft. Full-flow type oil filter. Exhaust emission control accomplished by fuel injection, Air Injection Reactor and Exhaust Gas Recirculation (some models also equipped with catalytic converter). Closed crankcase ventilation system and evaporative emission control system.

Type designation

Volvo B 27 F

Output (SAE J 245) at rpm	125 hp ¹⁾ /5500
Max. torque (SAE J 245) at rpm	150 lb.ft. ²⁾ /2750
Number of cylinders	6
Bore	3.42" (88 mm)
Stroke	2.87" (73 mm)
Displacement	2.66 liters
Compression ratio	8.2:1
Valve clearance cold engine	
inlet	0.0039–0.0059" (0.10–0.15 mm)
exhaust	0.0100–0.0120" (0.25–0.30 mm)

¹⁾ With catalytic converter: 121 hp.

²⁾ With catalytic converter: 148 lb.ft.

Cooling System

Type	Positive pressure, closed system
Thermostat, begins to open at	188°F (82°C)
fully open at	199°F (92°C)
Fan belts, designation	HC-38×1125

Fuel system

The engine is equipped with fuel injection system.

Specifications

Ignition System

Firing order	1-6-3-5-2-4
Ignition setting	
vacuum regulator and A.I.R. system disconnected, AC off	10° B.T.D.C. (at 700-800 rpm)
Sparks plugs	Champion BN9Y*
Spark plug gap	0.024-0.028" (0.6-0.7 mm)
Tightening torque	13-14.5 lbft (1.8-2.0 kpm)
Distributor, direction of rotation	Clockwise

ELECTRICAL SYSTEM

12 V, negative ground.

Voltage-controlled alternator. Single-wire system with chassis and engine used as conductors.

Voltage	12 V
Battery, type	Noack 12 H 70 B op
Capacity	70 Ah
Electrolyte, specific gravity	1.28
Recharge at	1.21
Alternator, rated output	770 W
max. current	55 A

* or corresponding

Lights, 12 V	US bulb No.	Power	Socket	No. of bulbs
Headlights, inner	5 ³ / ₄ " Type 1	Sealed Beam		2
Headlights, outer	5 ³ / ₄ " Type 2	Sealed Beam		2
Position Lights, front	67	5 W/4 cp	Ba 15 s	2
Turn Signals, front	1073	21 W/32 cp	Ba 15 s	2
Turn Signals, rear	1073	21 W/32 cp	Ba 15 s	2
Tail Lights	67	5 W/4 cp	Ba 15 s	2
Stop Lights	1073	21 W/32 cp	Ba 15 s	(265:2)
Back-up Lights	1073	21 W/32 cp	Ba 15 s	2
Side Marker Lights	57	3 W/2 cp	S 8.5	2

The following bulbs may be obtained from your nearest Volvo dealer:

Rear Ash Tray Light	1.2 W	W 1.8 d	1
License Plate Light	5 W	S 8.5	2
Interior Light	10 W	S 8.5	1 (265:2)
Glove box Light	2 W	Ba 9 s	1
Instrument Panel Light	2 W	Ba 7 s	3
Control Panel Light	1.2 W	W 1.8 d	3
Shift Positions,			
Autom. Transmission	1.2 W	W 1.8 d	1
Engine Compartment			
Light	15 W	S 8.5	1
Trunk light	15 W	S 8.5	1
Warning Lamps			
Charging	1.2 W	W 1.8 d	1
Turn Signals	1.2 W	W 1.8 d	2
Brake Failure	1.2 W	W 1.8 d	1
Parking Brake	1.2 W	W 1.8 d	1
Headlights	1.2 W	W 1.8 d	1
Oil Pressure	1.2 W	W 1.8 d	1
Overdrive	1.2 W	W 1.8 d	1
Warning Flashers	1.2 W	W 1.8 d	1
El. Heated Window	1.2 W	W 1.8 d	1
EGR Reminder	1.2 W	W 1.8 d	1
Seat Belts	2 W	Ba 9 s	1
Bulb Failure	1.2 W	W 1.8 d	1

Specifications

FRONT END

Suspension is of the McPherson type with the shock absorber mounted in a strut in the coil spring.

Rack and pinion steering gear.

Some models come equipped with power steering.

Safety steering column.

Front wheel alignment

The alignment specifications apply to an unloaded car but include fuel, coolant and spare wheel.

Toe-in	0.17 ± 0.06 (4.5 ± 1.5 mm)
	0.12 ± 0.06 (3.0 ± 1.5 mm) (models equipped with power steering).
Camber	+1° to +1½°

POWER TRANSMISSION

Cable-operated clutch of the single, dry-plate type.

Floor-shift operated manual transmission has four synchromesh forward gears and one reverse.

Optional automatic transmission.

Hypoid type final drive. Limited slip differential is optional.

Transmission

Type designation	M46	BW55
Reduction ratios		
1st gear	3.71:1	2.45:1
2nd gear	2.16:1	1.45:1
3rd gear	1.37:1	1.00:1
4th gear	1.00:1	—
Overdrive	0.80:1	—
Reverse	3.68:1	2.21:1

Rear axle	3.73:1	3.54:1
-----------	--------	--------

Speeds in mph (kmph) at 1000 engine rpm

Transmission	M46
Rear axle ratio	3.73:1
1st gear	5.2 (8.3)
2nd gear	8.9 (14.3)
3rd gear	14.0 (22.5)
4th gear	19.1 (30.8)
Overdrive	23.9 (38.5)
Reverse	5.2 (8.4)

Recommended max. and min. speeds, mph (kmph)

1st gear	2nd gear	3rd gear	4th gear
-30 (-50)	15-53 (20-85)	22-85 (35-135)	28* - (45-)

* 40 mph (60 kmph) with overdrive engaged.

Tool kit

Wheel nut and spark plug wrench.
 2 screwdrivers (1 Phillips, 1 standard)
 Tommy bar
 2 open end wrenches.

Tire pressures

Car model	Tire	Recommended tire infl. pressure cold tires, psi (kp/cm ²)				Max. permitted inflation pressure psi (kp/cm ²)	Capacity weight, lbs
		1-3 persons		Full load			
		Front	Rear	Front	Rear		
262/264	DR 78-14 185 R 14	26 (1.8)	28 (1.9)	26 (1.8)	32 (2.2)	32 (2.2)	920
265	DR 78-14 185 R 14	26 (1.8)	28 (1.9)	26 (1.8)*	32 (2.2)*	32 (2.2)	990

* For driving with full load, speed must be limited to 75 mph.

Consumer information

Consumer information

Acceleration and passing ability Vehicle stopping distance Tire reserve load

The information about the 1976 Volvo 262, 264 and 265 shown in the following pages is presented in accordance with Federal requirements for comparison with other makes and models. The exacting test procedures established by the National Highway Traffic Safety Administration were followed to obtain the figures.

Notice: This information represents results recorded by skilled drivers under controlled road and vehicle conditions and the information may not be applicable to other conditions.

Acceleration and Passing Ability

This chart indicates passing times and distances that can be met or exceeded by 1976 Volvo 262, 264 and 265 in the situations diagramed below.

Low speed

Initial speed: 20 mph

Limiting speed: 35 mph

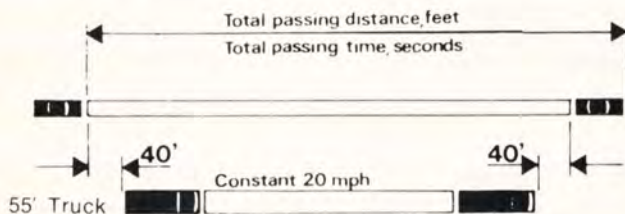

The low-speed pass assumes an initial speed of 20 mph and a limiting speed of 35 mph.

Model (vehicle without catalytic converter)	Low speed	
	Feet	Seconds
262/264 Overdrive	410	8.6
262/264 Automatic	414	8.8
265 Overdrive	411	8.7
265 Automatic	417	8.9

Model (vehicle with catalytic converter)	Low speed	
	Feet	Seconds
262/264 Overdrive	410	8.6
262/264 Automatic	414	8.8
265 Overdrive	410	8.7
265 Automatic	417	8.9

High speed

The high speed pass assumes an initial speed of 50 mph and a limiting speed of 80 mph.

Initial speed: 50 mph

Limiting speed: 80 mph

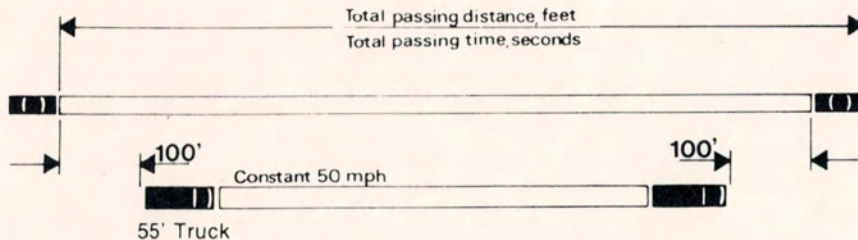

Model (vehicle without catalytic converter)	High speed	
	Feet	Seconds
262/264 Overdrive	1326	14.1
262/264 Automatic	1359	14.6
265 Overdrive	1336	14.3
265 Automatic	1372	14.8

Model (vehicle with catalytic converter)	High Speed	
	Feet	Seconds
262/264 Overdrive	1329	14.2
262/264 Automatic	1362	14.6
265 Overdrive	1346	14.4
265 Automatic	1378	14.8

Consumer information

Vehicle Stopping Distance

This chart indicates braking performance that can be met or exceeded by 1976 Volvo 262 and 264 without locking the wheels, under different conditions of loading and with partial failures of the braking system. This information represents results recorded by skilled drivers under controlled road and vehicle conditions, and the information may not be applicable to other conditions.

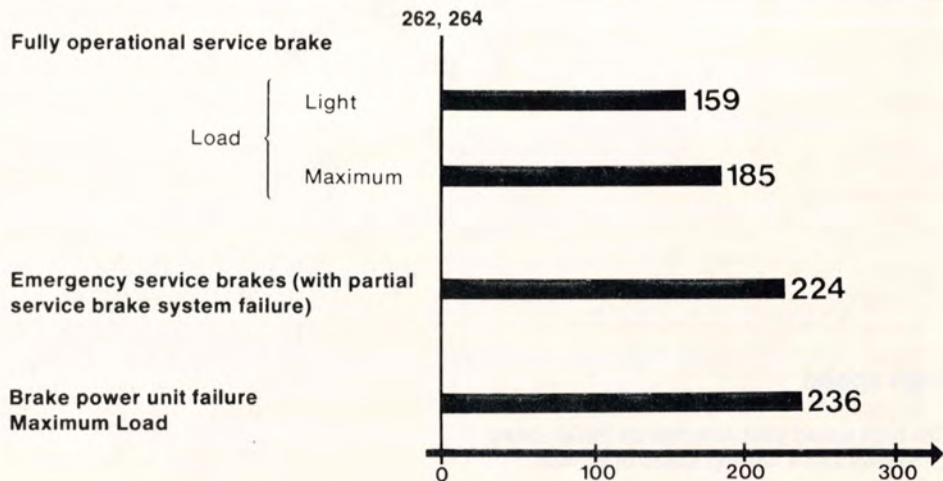

Stopping distance in feet from 60 mph.

Vehicle Stopping Distance

This chart indicates braking performance that can be met or exceeded by 1976 Volvo 265 without locking the wheels, under different conditions of loading and with partial failures of the braking system. This information represents results recorded by skilled drivers under controlled road and vehicle conditions, and the information may not be applicable to other conditions.

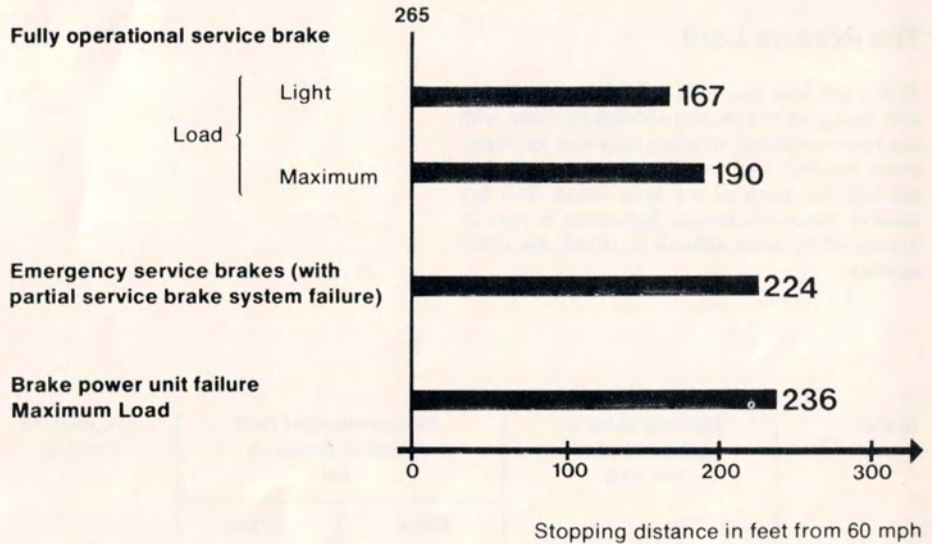

Consumer Information

Tire Reserve Load

This chart lists the 1976 262, 264 and 265 tire size designations recommended by Volvo with the recommended inflation pressure for maximum loading and the tire reserve load percentage for each of the tires listed. The tire reserve load percentage indicated is met or exceeded by each vehicle to which the chart applies.

Model	Manufacturer's recommended tire size	Recommended cold inflation pressure psi		Tire reserve load (%)
		Front	Rear	
262/264	DR 78 - 14	26	32	12.4
	185 R 14	26	32	10.1
265	DR 78 - 14	26	32	1.5
	185 R 14	26	32	4.4

WARNING. Failure to maintain the recommended tire inflation pressure or to increase tire pressure as recommended when operating at maximum loaded vehicle, or loading the vehicle beyond the capacities specified on the tire placard affixed to the vehicle, may result in unsafe operating conditions due to premature tire failure, unfavorable handling characteristics, and excessive tire wear. The tire reserve load percentage is a measure of tire capacity not of vehicle capacity. Loading beyond the specified vehicle capacity may result in failure of other vehicle components.

The difference, expressed as a percentage of tire load rating, between (a) the load rating of a tire at the vehicle manufacturer's recommended inflation pressure at the maximum

loaded vehicle weight and (b) the load imposed upon the tire by the vehicle at that condition.

Air Conditioning	16	Drain plug, engine	48	Ignition and steering wheel lock	8
Alternator, important note	60	rear axle	57	Ignition interlock system	21
Anti-freeze	59	transmission	56	Instrument lights	9
Anti-rust treatment	69	Drive belts	49	Instruments and controls	4
Ash trays	12	Driving with trunk lid open	39	Interior light	26, 63
Automatic transmission, driving oil	34 56	Electrically heated rear window	13	Jack	66, 85
Battery	40	Electrical system	83	Keys	3
Body and chassis	58	Emergency towing (pulling)	36	Kick-down	35
Brake fluid	42, 57	Emission control system	50	License plate lights	63
Brakes	39	Engine number	80	Lighting	8
Breaking in	31	Engine oil	48	Limited slip differential	57
Bulb failure warning light	7	Fan belt	49	Locks	22
Bulbs	60, 83	Fault tracing	83	Long distance trips	72
Capacities	81	Federal Clean Air Act	41	Lubrication	58
Chassis number	80	Fresh air controls	15	Lumbar support	18
Checking coolant	42, 59	Front seats	18	Maintenance Service	41
oil	48	Front wheel alignment	84	Odometer	6
Child safety locks	23	Frozen locks	22	Oil change, engine	48
Cigarette lighter	12	Fuel	26, 42	rear axle	7
Clock	12	Fuel gauge	6	transmission	56
Cold start	32	Fuel tank cap	26	Oil filter	48
Cold weather driving	73	Fuses	64	Oil pressure	7
Consumer Information	86	Gas filler cap	26	Overdrive	33
Control lights	6	Gasoline	26, 42	Paint touch-up	70
Coolant	59	Gas station checks	42	Parking brake	11
Coolant, drain	49	Gear shift positions	33	Parking lights	8
Defroster	14	Hand brake	11	Polishing	69
Dimensions and weights	81	Hazard warning flashers	13	Power steering	57
Dipstick	48	Headlight flasher	9	Rear axle oil	57
Door lock anti-freeze	73	Headlights	61	Rear, seat, 265	27
Doors and locks	22, 73	replacement	61		
		Hood lock	24		
		Horn	4		

Index

Rear view mirrors	25	Vehicle Identification Number	80
Rear window heating	13	Ventilation outlets	14
		Vent windows	25
Seat belts	21		
Seats	18	Warning lights	7
Service Diagnosis	75	Warranty	41
Servicing	42	Warranty inspection	31
Shift positions	33	Washer fluid	43, 73
Snow chains	65	Washer nozzles	10
Snow tires, studded tires	65	Washing	68
Spare wheel	29	Waxing	68
Spare plugs	83	Weights	81
Specifications	80	Wheel change	66
Speedometer	6	Wheels and tires	65
Starting engine	31, 32	Wintertime driving	73
Starting key	3	Wipers	10
Steering wheel lock	8		
Storage space, 265	27		
Sun roof	26		
Tachometer	6		
Tail gate	28		
Tail gate window washer/wiper	13		
Temperature gauge	6		
Tire pressure	65		
Tire reserve load	90		
Tires	65		
Tire wear indicator	65		
Tools	85		
Touch-up	71		
Trailer hauling	38		
Transmission oils	56		
Trunk, 262, 264	23		
Turn signals	9		
Type designations	80		
Upholstery, cleaning	69		

Tire pressures

Car model	Tire	Recommended tire infl. pressure cold tires, psi (kp/cm ²)				Max. permitted inflation pressure psi (kp/cm ²)	Capacity weight, lbs
		1-3 persons		Full load			
		Front	Rear	Front	Rear		
262/264	DR 78-14 185 R 14	26 (1.8)	28 (1.9)	26 (1.8)	32 (2.2)	32 (2.2)	920
265	DR 78-14 185 R 14	26 (1.8)	28 (1.9)	26 (1.8)*	32 (2.2)*	32 (2.2)	990

* For driving with full load, speed must be limited to 75 mph.

VOLVO

AB VOLVO · GÖTEBORG, SWEDEN
