

**VOLVO**

**DL**

**GL**

**GT**

عد



**OWNER'S MANUAL 1980 USA/CANADA**

**Notice to Owner:** Your Volvo has been built to comply with all U.S.A. and Canada safety and anti-pollution regulations. Evidence of this can be verified from the certification labels attached to the door opening sheet metal and on the left wheel housing in the engine compartment. For further information regarding these regulations, please contact your local dealer.

**Personal information**

Name OWEN EMMETT SMITH SR.  
REDITH VIRGINIA SMITH

Address 1049 6TH ST.

City, State GLEN BURNE, MD.  
21061.

Tel. No. 761-4790

**Car information**

Vehicle Identification Number (VIN) VC 24445A3547963

Ignition/Door Key No. 3A949

Trunk/Glove box Key No. 6329

Delivery Date 9 AUG 80

**Notice:** All information, illustrations and specifications contained in this manual are based on the latest product information available at the time of publication.

Volvo reserves the right to make model changes at any time, or to change specifications or design, without notice and without incurring obligation.



<b>DESCRIPTION</b>	<b>Page</b>		
General information	2	Gear shift positions	35
Keys	3	Automatic transmission	36
Instruments and controls	4	Emergency towing	38
Instruments	6	Towing information	39
Warning lights	7	Trailer hauling	40
Ignition switch, turn signal	8	Brake system	41
Lighting	9	Catalytic converter	42
Windshield wipers, tailgate wiper	10		
Washer fluid reservoirs	11	<b>MAINTENANCE SERVICE</b>	
Rear window demister		Maintenance services	43
hazard warning flasher	12	Gas station checks	44
Parking brake, choke	13	Engine B 21F, B 21A	45
Clock, cigarette lighter, ash tray	14	Servicing	46
Electrically operated windows	15	Engine oil	49
Heating and ventilation	16	Cooling system	50
Air conditioning	18	Servicing	51
Radios, AM – FM – FM stereo		Carburetor	54
CB/tape players	19	Transmission oil	57
Front seats	20	Rear axle, power steering, brake fluid	59
Seat belts	22	Lubrication	60
Doors and locks	24	Coolant	61
Rear doors, trunk lid	25	Alternator, jump starting	62
Hood	26	Replacing bulbs	63
Vent windows, Rear/side view mirrors	27	Fuses	70
Interior light, sun roof, fuel tank cap	28	Wheels and tires	71
Rear seat, wagon	29	Wheel changing	74
Tail gate, wagon	30	Replacing wiper blades	76
Cargo compartment wagon	31	Washing, cleaning	77
		Cleaning, anti-rust treatment	77
		Paint touch-up	78
		Long distance trips	80
		Cold weather	81
<b>STARTING AND DRIVING</b>		Service diagnosis	83
Service inspection	32	Specifications	88
Break in period	32	Volvo service manuals	94
Driving economy	33		
Starting the engine	34	<b>INDEX</b>	95

## General Information

---



### Model versions of the basic Volvo Models DL, GL, GT

Volvo DL 2 door, 4 door, Wagon

GL 4 door, Wagon

GT 2 door

Do not export your Volvo to another country before investigating that country's applicable safety and exhaust emission requirements.

In some cases it may be impossible to comply with these requirements.



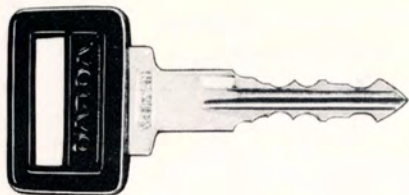

**Ignition/Steering wheel lock  
Front doors  
Tailgate (wagon)**

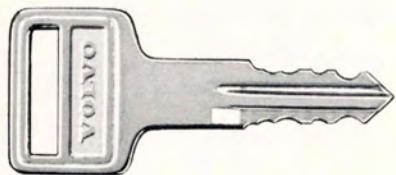

**Trunk  
Glove box**

**Write the key number codes on the inside of the front cover of this Manual (See tag attached to plastic key ring).**

**In the event the original keys are lost, duplicates may be ordered from your Volvo dealer.**

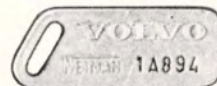

**Tag**

# Instruments and Controls

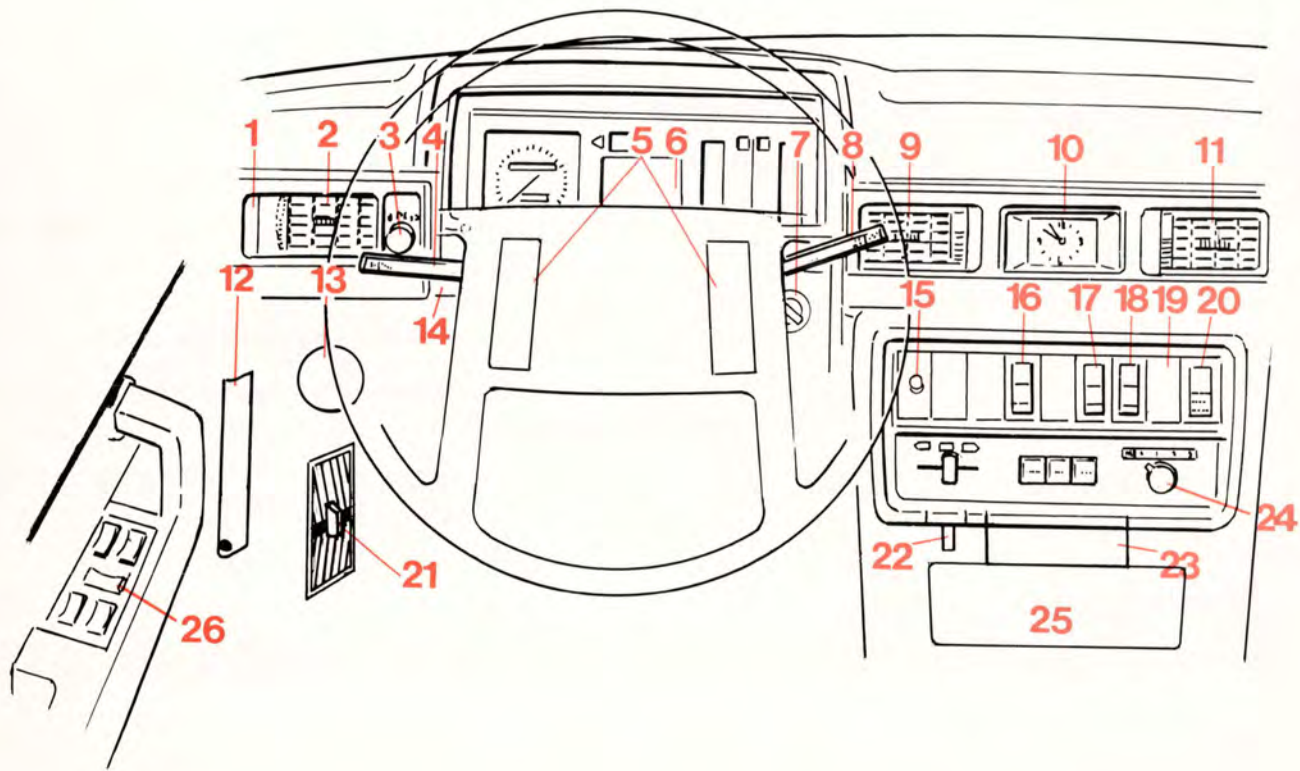

	<b>See page</b>
1 Defroster outlet, side window .....	16
2 Fresh air louver .....	17
3 Headlights, parking lights .....	9
4 Turn signals .....	8
5 Horn .....	—
6 Instruments .....	6
7 Ignition switch/steering wheel lock .....	8
8 Wiper/washer .....	10
9 Fresh air louver .....	17
10 Clock .....	14
11 Fresh air louver .....	17
12 Fuse box .....	70
13 Hood release handle .....	26
14 Choke control (Carburetor engines for Canada) .....	13
15 Instrument lights .....	9
16 Rear window demister .....	12
17 Hazard warning flasher .....	12
18 Fog lights (GT) .....	9
19 Air conditioning .....	18
20 Seat belt reminder light .....	22
21 Fresh air louver .....	17
22 Cigarette lighter .....	14
23 Ash tray .....	14
24 Heating and ventilation .....	16
25 Radio receptacle .....	19
26 Electrically operated windows .....	15

The pages in this section provide a detailed description of the vehicle's instruments and controls.

Note that vehicles may be equipped differently depending on specific legal requirements, etc.



# Instruments

## A Odometer

Total mileage reading

## B Speedometer

## C Left turn signal indicator (green)

## D Parking brake reminder light (red)

## E High beam indicator (blue)

## F Brake failure warning light (red)

## G Right turn signal indicator (green)

## H Oil pressure warning light (red)

## I Alternator warning light (red)

**Note:**  
Canadian model speedometers indicate kilometers only.

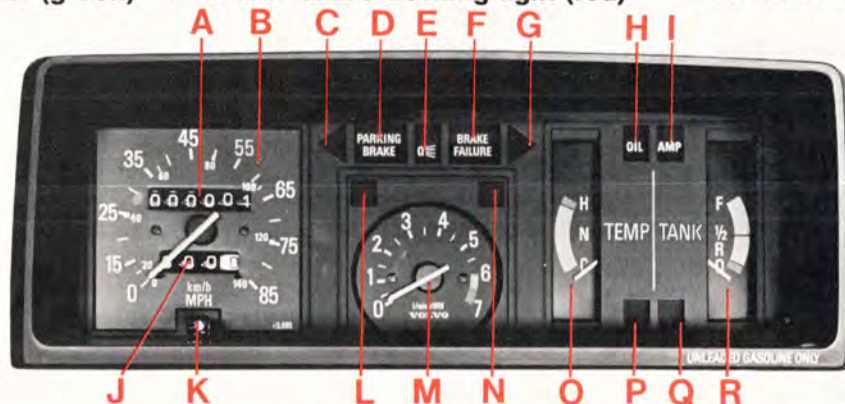

## J Trip odometer

(last figure represents 1/10 mile)

## K Trip odometer reset knob

Push in to reset

## L Reminder light, EGR/Lambda-sond™\* (oxygen sensor system) service

## M Tachometer (GT)

Reads thousands of engine rpm.

Orange range for momentary use, during acceleration. Red prohibited range

\* Lambda-sond™ is a trademark of Volvo of America Corporation.

## N Bulb failure warning light (yellow)

## O Temperature gauge

The gauge pointer should remain inside the green range during normal operation. If the pointer enters the red range repeatedly, check coolant level and fan belt tension. (See sections titled "Cooling System and Coolant".)

## P Overdrive indicator light (green)

Lights when overdrive is engaged.

## Q Choke reminder light (yellow)

Lights when choke is used.

(Certain Canadian models only.)

## R Fuel gauge

The fuel tank capacity is approx 15.8 US gals=60 liters/13.2 Imp. gals.

F Full

1/2

R Reserve

O Empty

The red range from R to O represents approx. 2.1 US gals=8 liters/1.8 Imp. gals.

### The warning lights described on this page should never be on when driving

When the ignition key is turned on, and before the engine starts, all of the warning lights should be on to test the function of the bulbs. Should a light not go off after the

engine has started, the system indicated should be inspected. (However, the parking brake reminder light will not go off until the parking brake is fully released.)

#### D Parking brake reminder light (red)



This light will be on when the parking brake (hand brake) is applied. The parking brake lever is situated between the front seats.

#### H Oil pressure warning light (red)



If the light comes on during driving, the oil pressure is too low. Stop the engine immediately and check the engine oil level. See section titled "Engine Oil". After hard driving, the light will come on occasionally when the engine is idling. This is normal, provided it goes off when the engine speed is increased.

#### L Lambda-sond™ (oxygen sensor system) service reminder light (red)



This is a reminder to have the oxygen sensor replaced. The light will stay on until reset by servicing dealer.

The light comes on at 30,000 mile (50,000 km) intervals.

#### F Brake failure warning light (red)



If the light comes on while driving and the brake pedal can be depressed further than normal, it is an indication that one of the brake circuits is not functioning. Proceed cautiously to a Volvo dealer for an inspection of the brake system.

#### I Alternator warning light (red)



If the light comes on while the engine is running, check the tension of the alternator drive belt as soon as possible. (See section titled "Cooling System".)

#### NOTE:

This warning light is illuminated if the alternator is not charging. However, **oil pressure, alternator, parking brake, brake failure, EGR, and bulb failure will be illuminated at the same time** due to the design of the system.

#### N Bulb failure warning light (yellow)



The light will come on if any of the following bulbs are defective:

- one of the lower beams
- one of the tail lights
- one of the brake lights (when the brake pedal is depressed).

See section on "Replacing Bulbs".



# Ignition switch, turn signals

## Ignition switch/steering wheel lock



**O Locked position:**  
remove the key to lock the steering wheel.



**I Intermediate position:**  
certain circuits ON (heater blower, cigarette lighter, accessories etc.).



**II Driving position:**  
key position when engine is running.



**III Starting position:**  
release the key when engine starts. The key returns automatically to driving position.

A buzzer will sound if the ignition key is in the ignition lock and the front door on the driver's side is open. The buzzer will also sound if the headlights or parking lights are on when the door is open.

The buzzer goes off when the front door is closed.

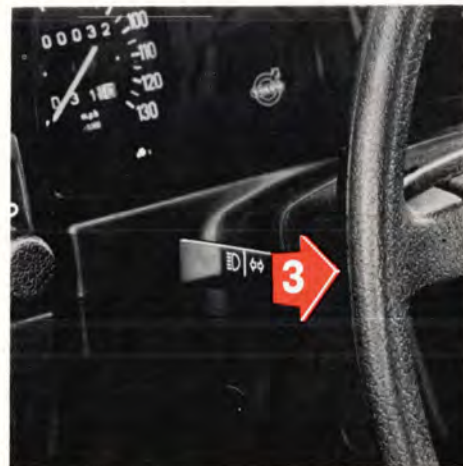
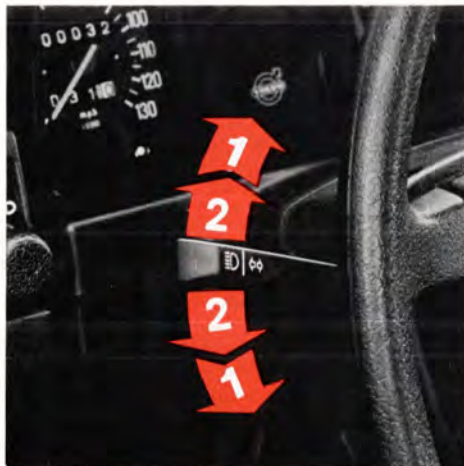

## Turn signals

### 1 Signal lever engaged for normal turns.

Defective turn signal bulb will cause turn signal indicator and remaining signal lights to flash more rapidly.

**2 Lane change position.** In maneuvers such as lane changing, the driver can flash the turn signals by moving the turn signal lever to the first stop and holding it there. The lever will return to the neutral position when released.

### 3 High and low beam switching (headlights on).

Move the lever towards the steering wheel and release it.

### 3 Headlight flasher (headlights off).

Move the lever towards the steering wheel. The headlight high beam will be on until the lever is released.





## Headlights and position lights

- 0 All lights off
- P Parking lights on
- D Headlights and parking lights on

Switch from upper to lower beams, and vice versa, by moving the turn signal switch lever on the left side of the steering column towards the steering wheel. The lights can be used without switching on the ignition key.

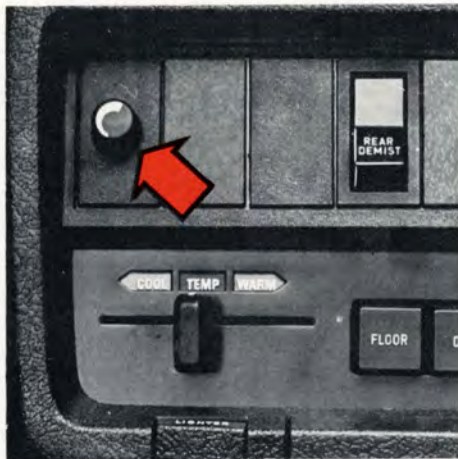

## Instrument panel lamps rheostat

Clockwise — brighter  
Counterclockwise — dimmer.

A buzzer will sound if the headlights or parking lights are on and the front door on the driver's side is open. The buzzer will also sound if the ignition key is in the ignition lock when the door is open. The buzzer goes off when the front door is closed.

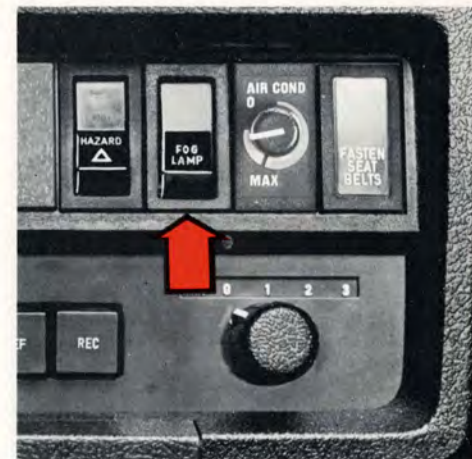

## Fog light switch (GT)

The fog lights will only operate in combination with the low beams in "on" position.

# Windshield wipers, Tailgate window wiper

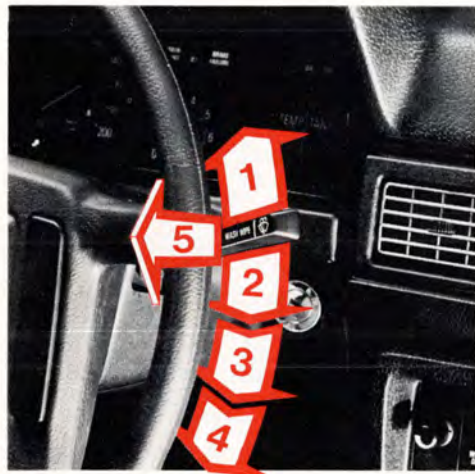

## Wiper/washer

### 1 Intermittent wiper

With switch in this position, the wipers will make a stroke every seventh second.

### 2 "Single stroke" position.

Switch returns automatically when released.

### 3 Wipers, low speed.

### 4 Wipers, high speed.

### 5 Windshield wiper/washer

The wiper will make 2-3 complete stroking cycles after the lever is released.

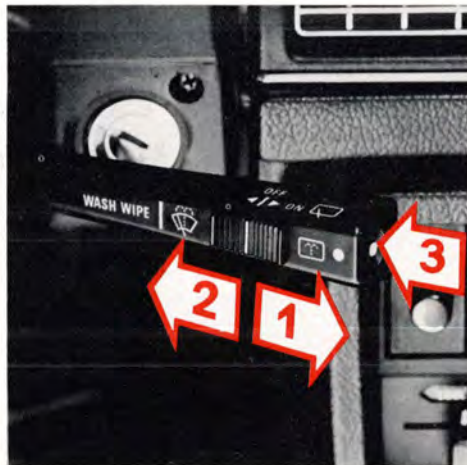

## Tailgate window wiper/washer, wagon

Operated by the switch at the end of the windshield wiper/washer operating lever.

### 1 Tailgate wiper

### 2 Interval position (optional)

With the switch in this position, there is one wiper stroking cycle approx. every five seconds.

### 3 Tailgate washer

Depress the button to start the washer.

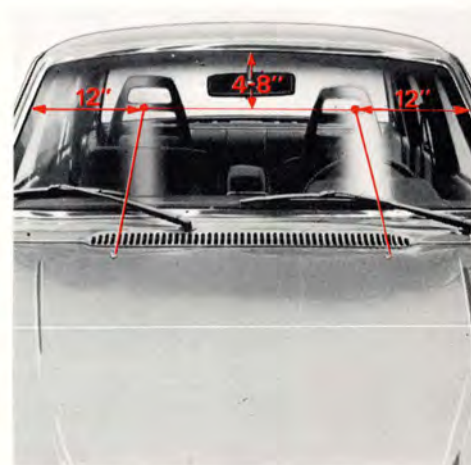

## Adjusting washer nozzles

The nozzles may be adjusted by inserting a needle into the metal nozzle and rotating the nozzle to desired position.



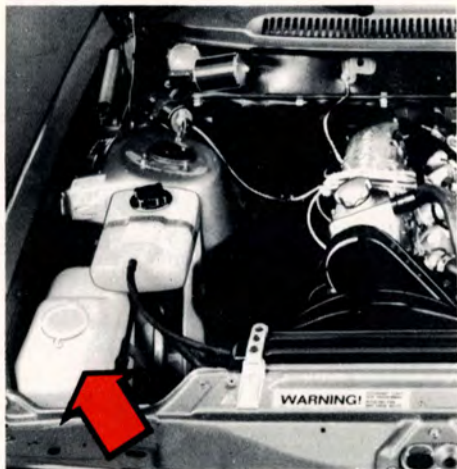

### Washer fluid reservoirs

The washer fluid reservoir for the windshield washer is located in the engine compartment and holds approx. 1.6 US gals = 6 liters/1.3 Imp gals.

The fluid reservoir for the tailgate washer on the wagon is located in the concealed storage area under the floor on the right side of the rear cargo area. Reservoir capacity is approx. 1.6 US qts. = 1.5 liters/1.3 Imp.qts.



# Rear window demister, hazard warning flasher

Rear window demister

Hazard warning flasher



## Rear window demister

Switch off the rear window heater when the glass is clear of mist or frost. Otherwise the battery will be unduly strained.

Do not place items against the inner surface of the rear window that may damage the printed circuit. Do not scrape the inner surface of the rear window glass with a hard object or use an abrasive window cleaner, otherwise damage to the printed circuit will occur.

## Hazard warning flasher

Four way flashing is used to indicate that the vehicle has become a traffic hazard (either during daylight or at night).

**NOTE:** Regulations regarding the use of the hazard warning flasher may vary from state to state.



### Parking brake (hand brake)

The lever is situated between the front seats. The brake is applied to the rear wheels. The reminder light PARKING BRAKE on the instrument panel comes on whenever the parking brake lever is not fully released and the ignition is on.



### Choke (only in cars with carburetor engines for Canada)

Pull the choke out fully before starting a cold engine.

Pulling the choke out a fraction of an inch or so regulates engine idling to some extent.

Choke light on the instrument panel goes on when the choke is pulled out.

**Use the choke as briefly as possible!**

Also see section titled "Starting the engine".

# Clock, cigarette lighter, ash tray

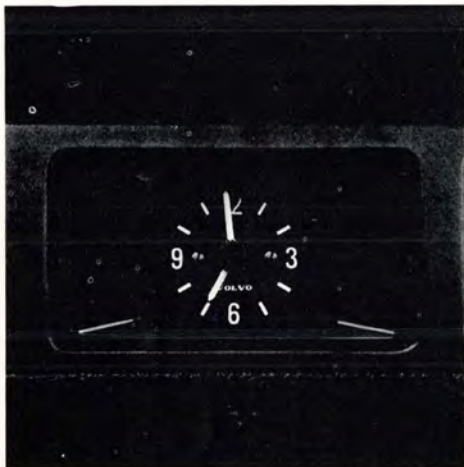

## Quartz crystal clock

To reset the hands, push in the reset knob and turn.

**Note:** A slight ticking sound may be emitted by the clock which is considered normal.

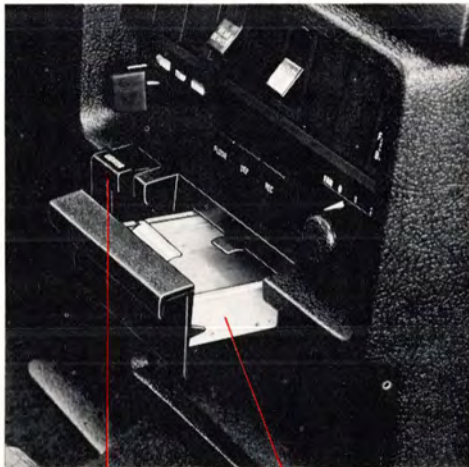

Lighter

Ash tray

## Cigarette lighter

To operate, depress the knob fully. When the knob automatically releases, the cigarette lighter is ready for use.

## Ash trays

To remove the ash trays depress the center spring and remove.

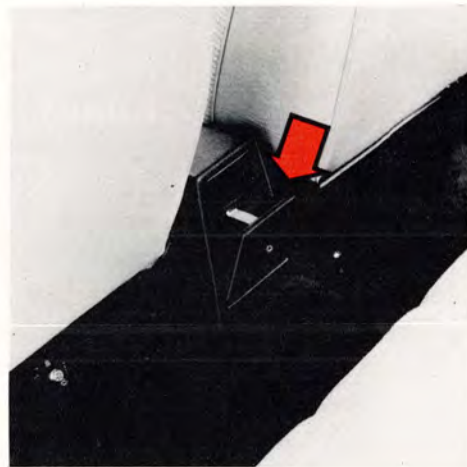

Rear seat ash tray



## Electrically operated windows

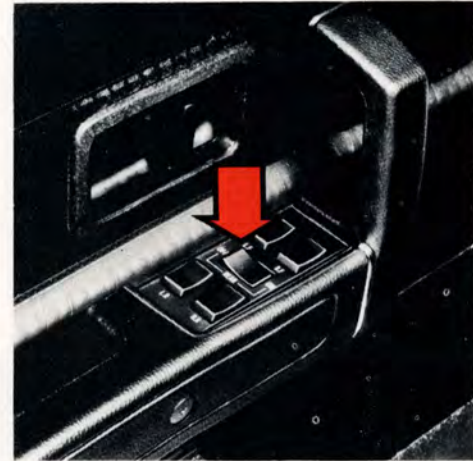
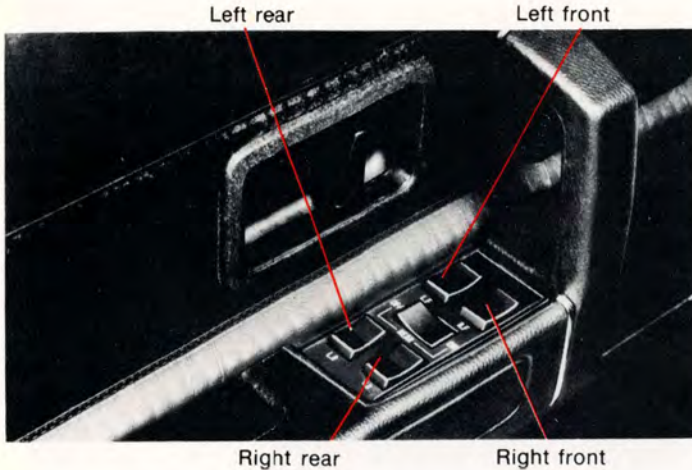

### Electrically operated windows

The electrically operated windows are controlled by switches set in the door arm rests. All the windows can be controlled from the driver's arm rest as shown in the above illustration.

The ignition must be switched on for the electrically operated windows to function. The window is lowered if the rear part of the switch is pressed and raised if the front part of the switch is pressed.

### Cut-out switch for rear door electrically operated windows

If the car is equipped with rear door electrically operated windows, this function can be disabled by a switch located on the driver's door arm rest. This switch is positioned 90° in relation to the other switches.

ON = Rear door windows can be raised or lowered

OFF = Rear door power windows disconnected

# Heating and ventilation

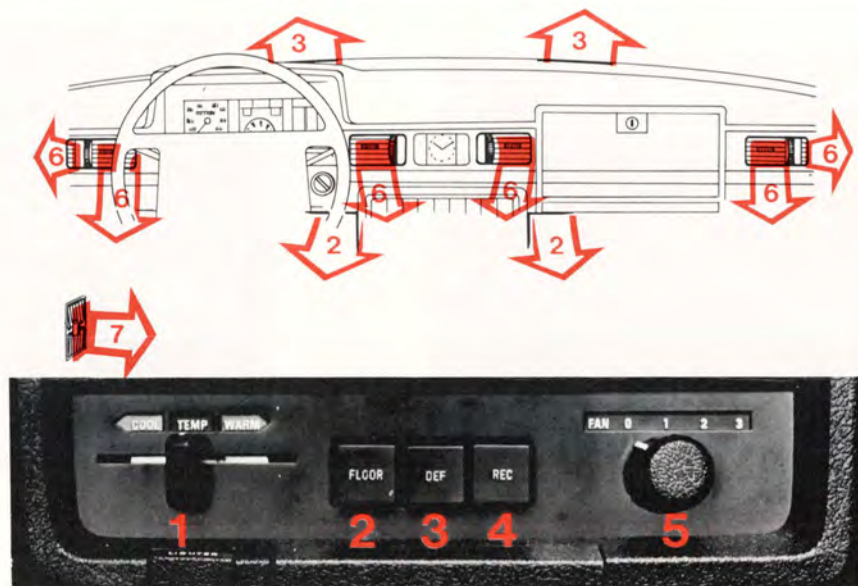

## Heating system

### 1 TEMP

Left = COOL  
Right = WARM

### 2 FLOOR

Out = no air to floor  
In = full flow of air to front and rear floor

### 3 DEF (defrost)

Out = low volume air flow to defroster  
In = full flow

### 4 REC (recirculation)

To be used only for cars equipped with air conditioning  
Do not use for heating.

Out = full flow of outside air  
In = air recirculated for faster cooling

### 5 FAN (Blower motor)

0 = off  
1 = low speed  
2 = medium speed  
3 = high speed

### 6 Fresh air louvers (dash)

The air flow through the louvers is slightly decreased when the FLOOR(2) and/or DEF(3) controls are depressed.

### 7 Fresh air louver (floor)

The air flow is controlled by the lever at the center of the louver.

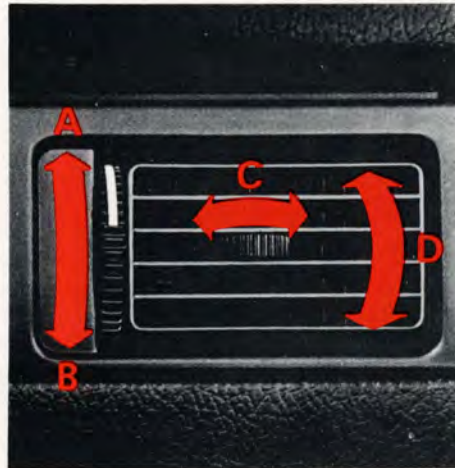

**Fresh air louvers (dash)**

- A Closed
- B Open
- C Directing air flow horizontally
- D Directing air flow vertically

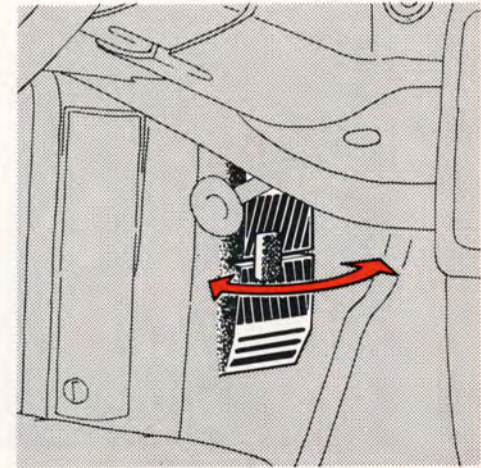

**Fresh air louvers (floor)**

There is a floor directed fresh air louver, on left side of vehicle. Air flow is controlled by the lever at the center of the louver.  
 Lever placed forward = louver opens  
 Lever placed rearward = louver closes  
 Maximum air flow is obtained with louver fully open and FAN (blower motor) OFF. (The fan forces the air through the dash louvers.)

**How to ...  
 ... obtain max. heat**

- 1 TEMP → WARM
- 2 FLOOR depressed
- 5 FAN → 2 (or 3)
- 6 All dash louvers halfway open and floor fresh air louvers closed

**... remove condensation**

- 1 TEMP → WARM
- 3 DEF depressed
- 5 FAN → 2 (or 3)
- 6 All louvers closed as well as the floor fresh air louvers.

Always try to keep front external inlet grille (in front of the windshield) clear of obstructions (snow, ice, etc.).

This will help ensure availability of fresh air into the passenger compartment.



# Air conditioning



## Air conditioning

How to use the air conditioner:

### 1 FAN

Position 3 for rapid cooling.

**The A/C does not operate unless FAN is on.**

### 2 AIR COND

Start the air conditioning compressor by turning the control knob clockwise toward MAX. For rapid cooling, position the knob into the yellow range beyond MAX. After desired temperature is reached re-position the control knob into the blue range.

**At cruising speeds, the knob should be kept within the blue range.** If it remains in the yellow range, icing may occur resulting in decreased cooling capacity.

### 3 REC (Recirculation)

Push in for rapid cooling and during high humidity conditions.

### 4 TEMP

When using the air conditioner for cooling, the TEMP control should be set to COOL position, fully left. Use the AIR COND control to regulate the temperature.

To obtain rapid cooling, all windows must be closed and buttons FLOOR and DEF out. Close the floor fresh air louver.

Cool air will then be discharged through the four dash outlets which should be fully open.

**NOTE:** For rapid removal of condensation from inside glass surfaces, the air conditioner can be switched on even when not required for interior cooling. The air conditioner will dehumidify the air inside the vehicle.

The air conditioning system should be operated periodically during the winter season. Have your Volvo dealer check the system for correct operation yearly.

## Radios, AM-FM-FM stereo – CB/Tape players



### Operating instructions

This equipment is optional and is available in various models, each providing slightly different capabilities. Operating instructions are contained in the manuals associated with each model.

These manuals are placed in the cars when the equipment is installed by the Dealer.

Your Volvo Dealer will be able to assist you with any questions regarding the operation of this equipment.

**NOTE:** Operation of Citizens Band (CB) radios is governed by Federal Regulations.

You must obtain a special license before operating this equipment.



## Front seats



### Horizontal seat adjustment

Pull control bar upward, then slide seat forward or rearward to desired position.

**Make sure that the seat is properly secured when you release the control.**

**WARNING!** For your safety, never adjust seat while driving.

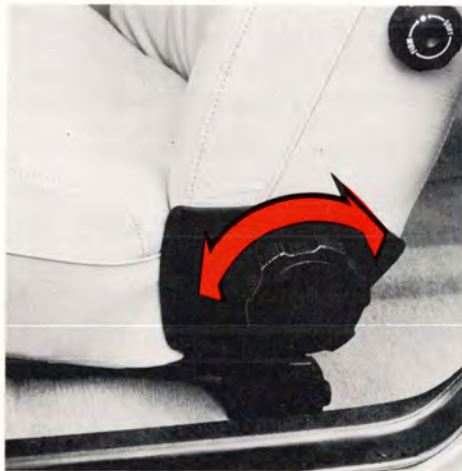

### Seat back inclination adjustment

Rotate control clockwise to tilt seat back rearward.

Rotate counterclockwise to tilt seat back forward.

**Note that body weight must be shifted to allow seat back to move forward.**

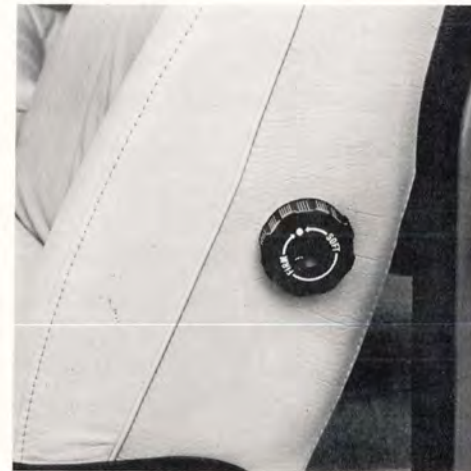

### Lumbar support adjustment

Rotate clockwise for firm support or counterclockwise for soft support.

### Canada only:

The driver's seat is electrically heated and is thermostatically controlled. Automatic engagement begins at 60° F (+15° C) and ends at 77° F (+25° C).





### Seat back release, 2-door models

Press the button and fold seat back forward to allow passengers access to/from the rear seats.

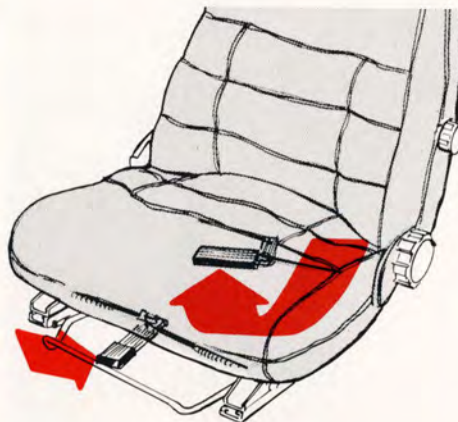

### Driver seat height

There are two levers, each with three positions, for adjusting the height of the seat (front and/or back of cushion).

This allows adjustment of the seat cushion angle for added comfort.

After adjusting the seat check that it is securely latched.

**NOTE! Do not attempt to adjust seat height while seated.**

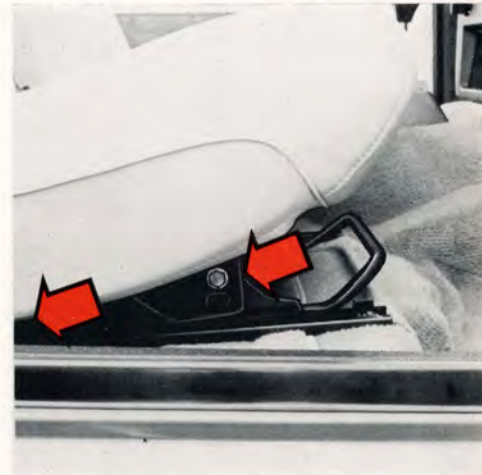

### Passenger seat height

The front passenger seat is retained by four brackets, each with three positions. The positions are the same as the driver's seat. However, this adjustment must be accomplished manually using appropriate hand tools.

# Seat belts



Front seats



Rear seats

## Seat belts, retractable

### Fasten the seat belts whenever you drive or ride.

Two lights will be illuminated for 4–8 seconds after the ignition key is turned to driving position. One light is located in the instrument cluster and one in the console between the front seats.

A buzzer will sound at the same time if the driver has not fastened his seat belt.

The front and rear outboard seats are provided with self-retracting inertia belts.

## To buckle:

Pull the belt out from the retractor far enough to insert the latch plate into the receptacle (buckle for rear seats), until a distinct snapping sound is heard. The belt should not be twisted or turned.

To unfasten, depress red pushbutton in receptacle (buckle) and let the belts rewind into their retractors.

The seat belt retractors are normally unlocked. The retractors will lock up as follows:

- if belt is pulled out rapidly
- during braking and acceleration
- if the vehicle is leaning excessively
- when cornering at speed

Check seat belt mechanism function as follows:

- 1 Attach the seat belt. Pull rapidly on the strap.
- 2 **CAUTION: Check other traffic before accomplishing this check.**

Brake firmly from approximately 30 mph (50 km/h) or turn in a tight circle while pulling on the belt.

In all the above checks you should not be able to pull the belt out.





### Seat belts, manually adjustable

The center rear seat belt is manually adjustable. It should always be adjusted to the correct length.

**To lengthen**, angle the buckle as shown in the illustration and pull the belt through.



**To shorten**, pull the upper part of the double webbing until snug.

### Maintenance

Check periodically that the anchor bolts are secure and the belt in good condition.

Use water and a mild detergent for cleaning.

**As the seat belts lose much of their strength when exposed to violent stretching, they should be replaced after collision, even though they may appear to be undamaged.**

Never modify or repair the belt on your own, but have this done by a Volvo workshop.



## Doors and locks



### Unlocking front doors

Both front doors can be unlocked by using the ignition key. Turning the key 1/4 turn counterclockwise (right door: clockwise) lifts the lock buttons in the window ledge and the door can be opened by pulling the handle. To open a door from inside, the lock button must first be pulled up.

In wintertime the door locks should be "lubricated" with a suitable agent to prevent freezing. If the lock is frozen, be careful not to break the key in the lock. Thaw the ice by heating the lock or the key. Use electric heater with blower to prevent paint damage when thawing lock.

### Locking doors

All doors can be locked by depressing the lock buttons. To lock a door, press down the lock button and shut the door.

#### **Do not leave the key inside the car!**

Both front doors can be locked by using the key. Turning the key 1/4 turn clockwise (left door) or counterclockwise (right door) locks the doors.

**The lock buttons should not be in the down position during driving. In case of an accident, this may hinder rapid access to the occupants of the vehicle.**

### Central lock

All models except DL, 2 door, and GT are equipped with a central lock. This means the lock on the driver's door automatically controls the locks on the other doors (including the tailgate on the wagon model).

If the driver's door is locked or unlocked from the outside using the key, the other doors will automatically be locked or unlocked.

To lock/unlock the car by using the lock button on the inside of the driver's door, push/pull gently to lock/unlock only the driver's door or slightly harder to lock/unlock all the doors. Check the action of the buttons on the other doors to ensure their correct function (lock/unlock).

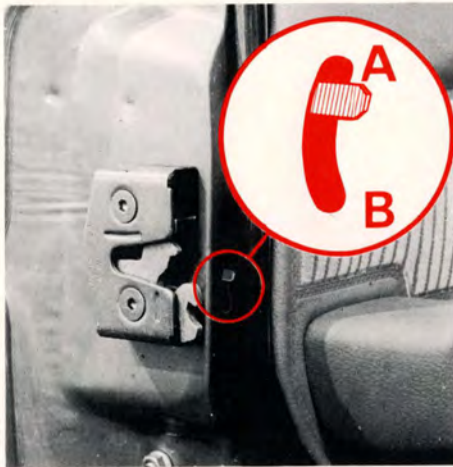

### Child safety locks (all except 2 door models)

The buttons are located on the rear door jambs.

A Normal lock function.

B The door **cannot** be opened from the **inside**.

**Remember, in the event of an accident, the rear seat passengers cannot open the doors from the inside with the buttons in position B.**

Wagon model contains child safety lock on tailgate. The lock differs from that shown above. See section titled "Wagon, tailgate".



### Trunk lid (2 and 4 door models)

**The lid can only be opened by using the key.**  
Open by turning the key 1/4 turn, as shown.  
The spare wheel jack and tool kit are stowed in the left side of the trunk.

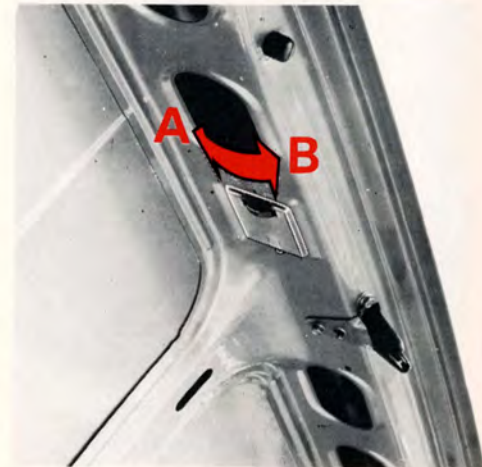

### Trunk light (2 and 4 door models)

A Light always off

B Light is on when trunk lid is opened.

# Hood

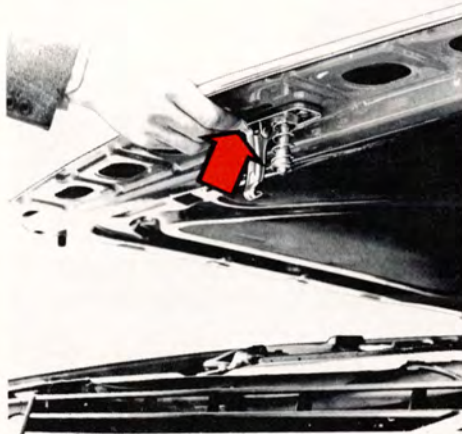
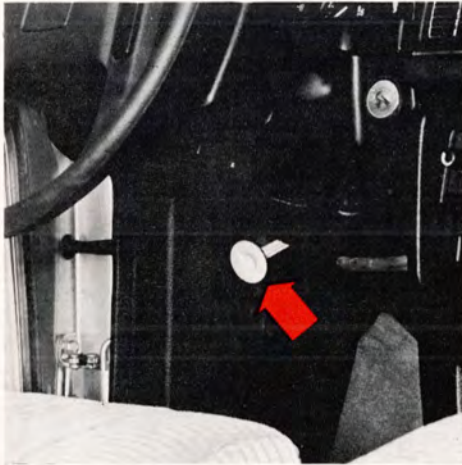

## To open the hood

Pull the release handle (located under the left side of the dash).

Lift the hood slightly, insert a hand under the center line of the hood and depress the safety catch handle. Open the hood.

**Check that the hood locks properly when closing.**



## Vent windows, rear view mirrors

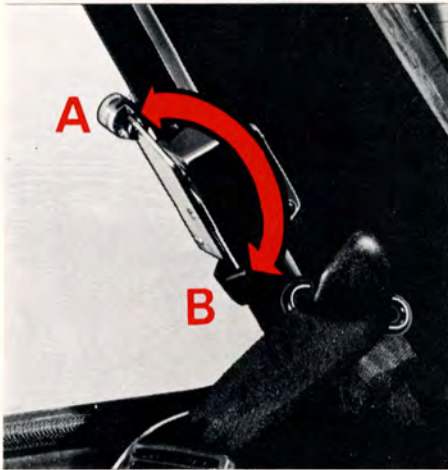

**Rear vent windows, 2-door models**

- A Open
- B Closed



**Side view mirrors**

- A Adjustment sideways
- B Adjustment up/down

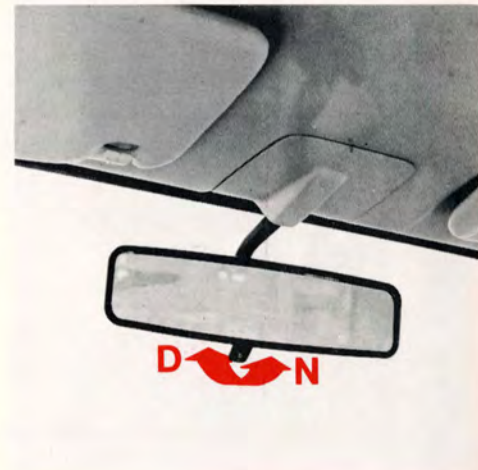

**Rear view mirror**

- D Normal position
- N Night position, reduces glare from following headlights

**The mirrors should always be adjusted before driving.**

## Interior light, sun roof, fuel tank cap

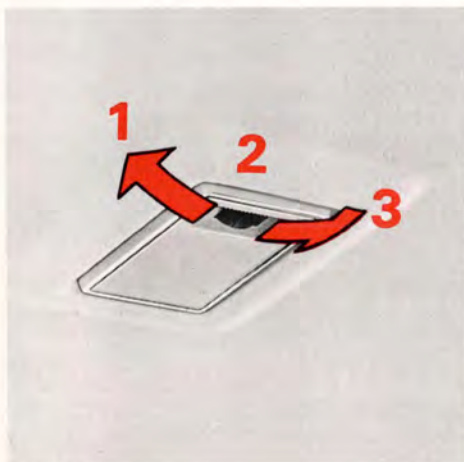

### Interior light

- 1 Light always on.
- 2 Light always off.
- 3 Light is on when either of the front doors are opened.

The wagon model may be equipped with a light that differs from that in the 2 and 4 door models.



### Sun roof (certain models)

The sun roof is operated by a handle located between the sun visors. Unfold the handle and turn it counterclockwise to open, clockwise to close. For safety reasons the handle should always be folded when driving.



### Filling fuel

The gas cap is located behind the door on the right rear fender.

When filling, position the cap in the special bracket on the door.

After filling the tank, install the cap and turn until a "click" is heard.

**Note: Unleaded fuel is required for all models (except Canada). A label on the instrument panel and rear fender, near the filler inlet, will remind owners and filling station attendants of this requirement.**

**Important! It is unlawful to dispense leaded fuel into any vehicle labeled "unleaded gasoline only".**

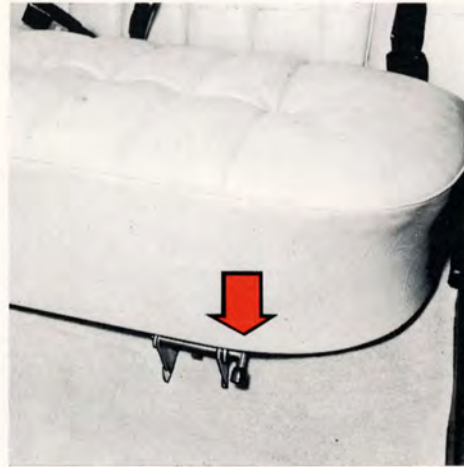

The following three pages describe the rear seat, tailgate and cargo compartment of the wagon model.

### Folding rear seat

Depress either lever located at the front bottom edge of the rear seat cushion (right or left side). Tilt the seat towards the front seat.

The front seats may have to be moved forward slightly to allow rear seat to fold down completely.

Pull the handle on the rear side of the seat back sideways, and fold the seat back forward and down so that it lies flat. The rear seat back and cushion are held automatically in their respective positions.

When returning the rear seat to its normal position, make sure the latches are securely locked and the seat belts lie on top of the seat back so they can easily be used.



## Wagon, tailgate

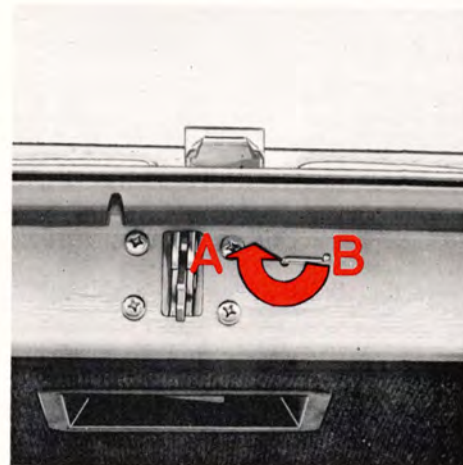
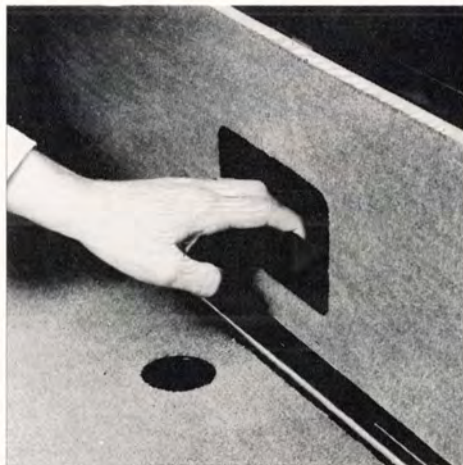

### To open from the outside

Depress the release button located under the tailgate handle.

### To open from the inside

Pull out the T-handle located at the bottom of the tailgate.

### Safety catch

A The lid cannot be opened from the inside.  
B The lock functions normally.

## Wagon, cargo compartment, eyelets

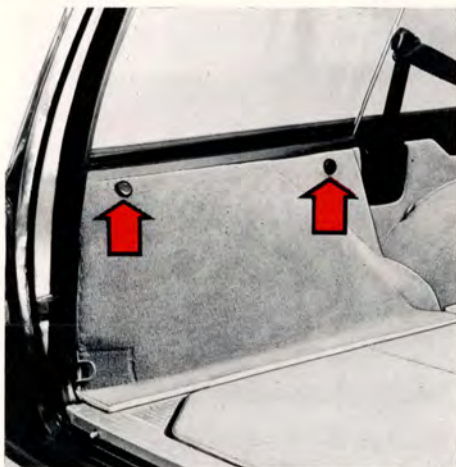

### Spare wheel, jack

The spare wheel and jack are stored under the hatch to the left in the cargo compartment. Loosen the two screws (knurled knobs) and lift off the hatch.

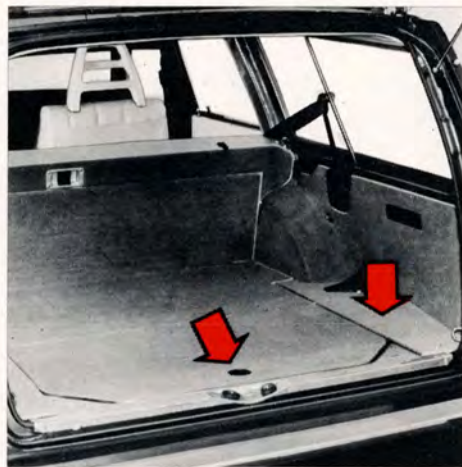

### Concealed storage space

There are two concealed storage areas under the cargo compartment floor. The tailgate window washer fluid reservoir is located in the right side area.

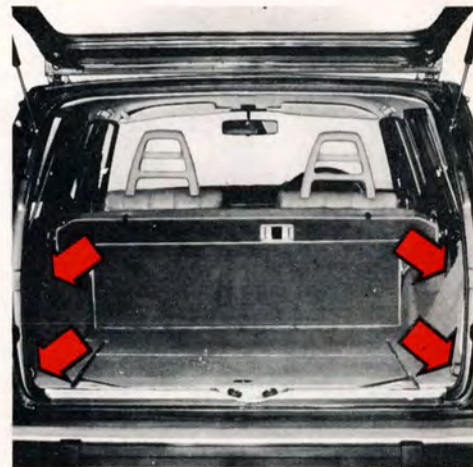

### Eyelets

Six eyelets are provided in the cargo compartment for anchoring cargo. Only 4 are shown in the illustration. The remaining two are accessible when the seat back is folded forward.

**Note: The eyelets are not to be used as occupant restraints.**

# Starting and Driving

**A new car should be broken in!**

### 4-speed transmission

During the break in period do not exceed the following speeds:

#### First 600 miles (1,000 km)

1st gear	20 mph	(30 km/h)
2nd gear	30 mph	(50 km/h)
3rd gear	50 mph	(80 km/h)
4th gear	70 mph <sup>1</sup>	(110 km/h <sup>1</sup> )

#### 600–1,200 miles (1,000–2,000 km)

1st gear	25 mph	(40 km/h)
2nd gear	45 mph	(70 km/h)
3rd gear	60 mph	(100 km/h)
4th gear	80 mph <sup>2</sup>	(130 km/h <sup>2</sup> )

Avoid driving at low speed in high gear

<sup>1</sup>) 80 mph (130 km/h) with overdrive engaged. Do not use overdrive below 40 mph (65 km/h).

<sup>2</sup>) 90 mph (150 km/h) with overdrive engaged.

### Automatic transmission

Do not use "kick-down" when driving a car equipped with an automatic transmission during the first 1,200 miles (2,000 km).

### Service Inspection

To ensure proper operation the car should be taken to a Volvo dealer between the first 600–1,200 miles (1,000–2,000 km) for a service inspection. The oil in the engine, 4-speed transmission and rear axle will then be changed. This is very important since the oil rapidly collects impurities during the break in period.



### Economical driving does not necessarily mean driving slow

Better driving economy may be obtained by thinking ahead, avoiding rapid starts and stops and adjusting the speed of your vehicle to immediate traffic conditions. Observe the following rules:

- Bring the engine to normal operating temperature as soon as possible by driving under light load. A cold engine uses more fuel and is subject to increased wear.
- When possible avoid using the car for driving short distances. This does not allow the engine to reach normal operating temperature.
- Drive carefully and avoid rapid acceleration and hard braking.
- Do not exceed speed limit.
- Avoid carrying unnecessary items (extra load) in the car.
- Check tire pressure regularly – when tires are cold.
- Remove snow tires when threat of snow or ice has ended.
- Note that roof racks, ski racks, etc., increase air resistance and thereby gas consumption.

Utilize the transmission to improve fuel economy.

Use correct gear!

- From first to second gear at approx. 10 mph (20 km/h)  
From second to third gear at approx. 20 mph (35 km/h)  
From third to fourth gear at approx. 30 mph (50 km/h)
- If vehicle is equipped with overdrive, use it at every opportunity (at speeds in excess of 40 mph = 65 km/h).
- Avoid using automatic transmission kick-down feature unless necessary.

Other factors which decrease gas mileage are:

- Worn or dirty spark plugs
- Incorrect spark plug gap
- Dirty air filter
- Incorrect valve clearance
- Incorrect idle speed
- Dirty engine oil and clogged oil filter
- Dragging brakes
- Incorrect front end alignment
- Low tire pressure

The above mentioned items, and others are checked at the standard 7,500 Mile (12,500 km) Maintenance Service intervals.

# Starting the engine

---

To start the engine:

## Injection engine (B21F)

- 1 Enter the car and fasten the seat belt.
- 2 Apply the parking brake, if not already set.
- 3 Place the gear selector lever in neutral (position N or P, automatic transmission).
- 4 Depress the clutch pedal (manual transmission).
- 5 Press down gas pedal about 1 inch (25 mm) (1/4 of total stroke).
- 6 Turn key to starting position. When engine has started, release the key and gas pedal.

If the engine does not start at once, depress the throttle pedal half way and keep it there until the engine starts.

Avoid repeated short attempts to start (fuel is injected every time the starter is engaged when engine is cold).

Allow the starter to operate for a longer time (but not more than 15–20 seconds).

**Do not race a cold engine immediately after starting.**

## Carburetor engine (B21A, Canada)

- 1 Enter the car and fasten the seat belt.
- 2 Apply the parking brake, if not already set.
- 3 Place the gear selector lever in neutral (position N or P, automatic transmission).
- 4 Depress the clutch pedal (manual transmission).

### 4 Cold engine

**Temperature below 50° F (+10° C):**

Pull out the choke fully, do not touch the gas pedal.

**Temperature above 50° F (+10° C):**

Pull out the choke 3/4 of its travel.

**Hot engine:**

Depress gas pedal half-way.

If the engine does not start immediately when hot, depress the gas pedal to the floor and keep it there until the engine starts.

- 5 Turn the ignition key to start position. Release the key when the engine has started.
- 6 Push in the choke until best idling is obtained. Push it in more and more as the engine becomes warmer. The choke should be pushed fully in when the engine is thoroughly warm.

**Do not race a cold engine immediately after starting.**

## Warning

Always open the garage doors fully before starting the engine inside the garage to ensure adequate ventilation. The exhaust gases contain carbon monoxide, which is invisible and odorless but very poisonous.

## Engine warm-up — initial driving procedure

Experience shows that engines in vehicles driven short distances are subject to abnormally rapid wear because the engine never reaches normal operating temperature. It is therefore beneficial to reach normal operating temperature as soon as possible. This is achieved by driving with a light load as soon as possible.





## 4-speed transmission

Depress the clutch fully when changing gears.



Overdrive engaged



Overdrive disengaged

## Overdrive (some models only)

Shift to overdrive at 45 mph (70 km/h) and disengage it when speed drops below 40 mph (65 km/h) or vehicle encounters hilly terrain. The overdrive can be engaged in 4th gear only.

No extra operation of clutch or throttle pedal is normally necessary. **Engagement** is facilitated if the accelerator pedal position is maintained steady.

When **disengaging**, depressing the clutch pedal slightly makes a smooth transfer.

The overdrive should be used after the engine has reached normal operating temperature (minimum time is five minutes) and the vehicle is being operated on relatively level roads.

Downshifting to a lower gear will automatically disengage the overdrive.

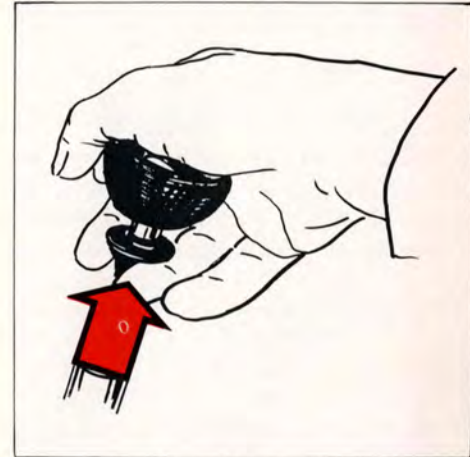

## Reversing inhibitor

Lift the ring to enter reverse gear. The ring locking mechanism prevents reverse gear from being engaged unintentionally.



# Automatic transmission

P  
R  
N  
D  
2  
1

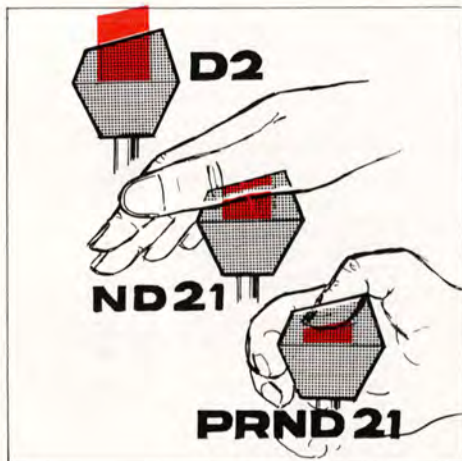

## Shift positions

- P park
- R reverse
- N neutral
- D drive
- 2 intermediate
- 1 low

The gear selector can be moved freely between D and 2. The other positions are separated by a lockout which is operated by depressing the selector knob.

## Shift gate

Depressing the selector knob slightly allows selection of positions **N** and **1**.

Depressing the selector knob fully allows selection of positions **R** and **P**. This is also necessary when initially bringing the selector out of position **P**.

Depressing the selector knob fully thus permits shifting freely between all positions.

## P Park

Use this position when parked with the engine running or stopped.

**Never use P while car is in motion.**

The transmission is mechanically locked in position P. Also use the parking brake when parking on grades for added safety.

## R Reverse

**Never use R while car is moving forward.**

## N Neutral

Neutral position = no gear is engaged.

**Use parking brake!**

## Driving gears

### D Drive

D is the normal driving position. Upshift and downshift of the three forward gears occurs automatically and is governed by throttle opening and vehicle speed.

## 2, intermediate position

Upshift and downshift of first two gears (low and intermediate) occurs automatically.

**No** upshift to 3rd (top) gear occurs.

Position 2 may be used to obtain forced downshift to 2nd gear for increased engine braking effect.

Position 2 can also be used ...

- for relatively slow highway driving.
- for city driving.
- when driving on mountain roads where precise speed control is desirable.
- for passing.

**Top speed when selecting 2 is 70 mph (110 km/h).**

## 1, low position

If position 1 is selected when driving at high speeds, 2 is engaged first and 1 when the speed has dropped to approx. 30 mph (50 km/h).

**NOTE: No upshift once 1 is engaged.**

Use position 1 to select low gear with no upshift. For instance, when entering and descending steep grades.

**Top speed when selecting 1 is 70 mph (110 km/h).**

## Kick-down

Automatic shift to a lower gear is achieved by depressing the throttle pedal briskly (passing the normal full throttle position).

An up-shift will be achieved when approaching the top speed for a particular gear or by releasing the throttle pedal slightly.

Kick-down can be used for maximum acceleration or when passing at highway speeds.

## NOTE:

- **Never select P or R while the car is in motion.**
- **When initially selecting positions D, 2, 1 or R the car should be standing still with the engine idling.**
- **Never select positions 2 or 1 at speeds above 70 mph (110 km/h).**

## Starting and stopping a car equipped with automatic transmission

- 1 Fasten the seat belts.
- 2 Apply the parking brake or the brake pedal to hold the car (to prevent the car from moving when the gear selector is moved).
- 3 Select position **P** or **N**. (Engine cannot be started in any other position.)
- 4 Start the engine by turning the ignition key.
- 5 Select desired gear.
- 6 Release the brake and accelerate.

**To stop the car**, release the throttle pedal and apply the brakes.

It is not necessary to move the gear selector as the transmission will downshift automatically.



## Emergency towing (pulling)

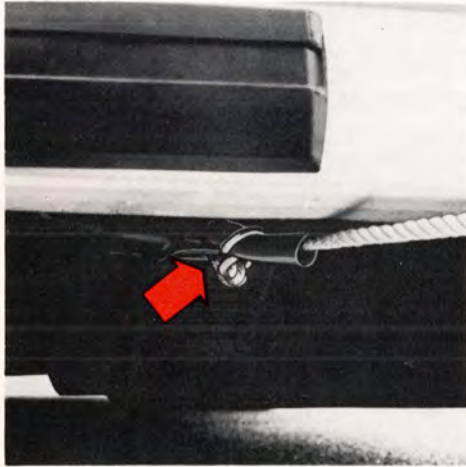

Front eyelet (without air dam)

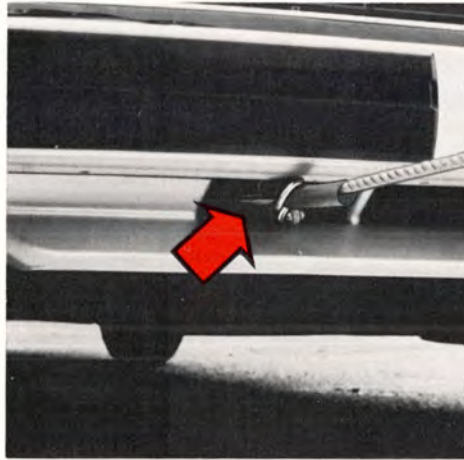

Front eyelet (with air dam)

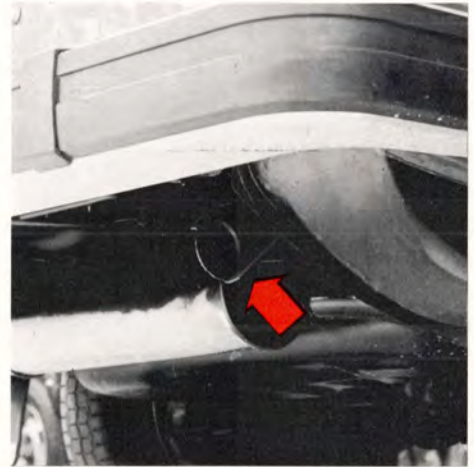

Rear eyelet

### Precautionary steps to observe when towing

- Steering must be unlocked.
- Observe legal speeds.
- Remember that power brake and power steering assists will not be available when engine is inoperative. Pedal pressure required is 3–4 times above normal and greater steering effort must be employed.

### Towing cars equipped with automatic transmission:

- Gear selector in position N. Check transmission oil (see section titled "Transmission Oil").
- Maximum speed: 20 mph (30 km/h).
- Maximum distance: 20 miles (30 km).

**Cars equipped with automatic transmission cannot be started by pushing or pulling.**

**Jump starting, see section titled "alternator, jump starting".**



## FRONT

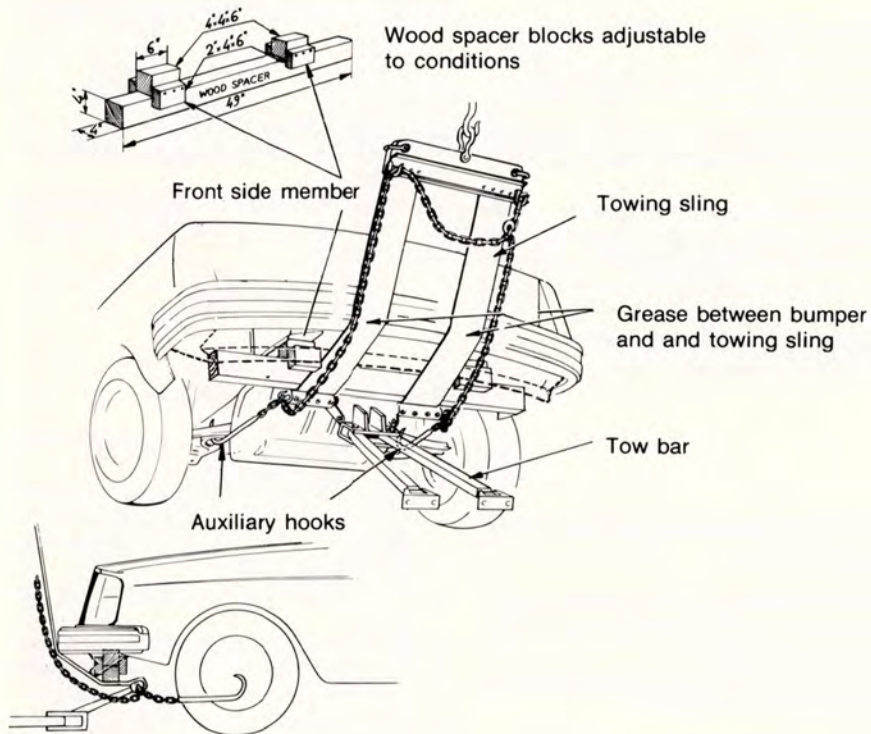

## REAR

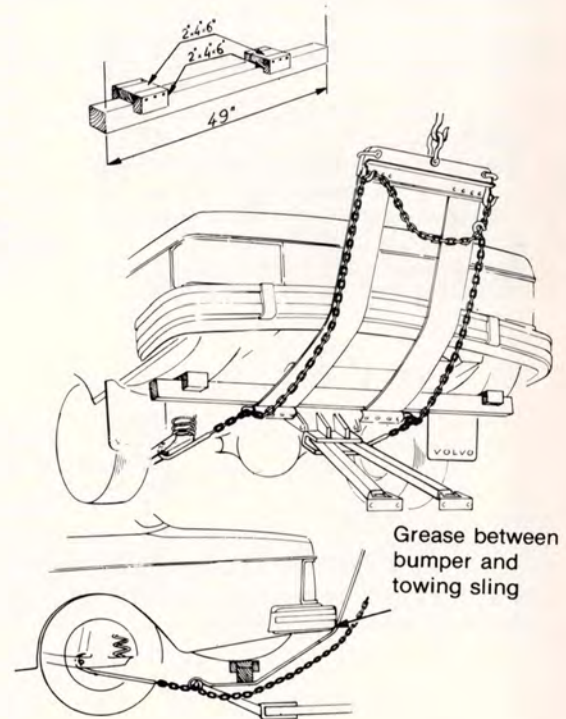

# Trailer hauling

## When preparing for trailer hauling, observe the following:

All Volvo models are equipped with energy absorbing shock mounted bumpers. Trailer hitch installation should not interfere with the proper operation of this bumper system.

Bumper mounted or installed trailer hitches are not recommended for use on Volvo cars.

- Use a trailer hitch which meets Federal Safety Standards for rear end collisions (FMVSS 301-75) such as those offered as Genuine Volvo Accessories.
- Maximum trailer weight recommended by Volvo is 2,000 lbs (908 kgs). Observe legal requirements of the State in which the vehicles are registered.

### Note:

Additional lighting equipment must be connected to specific points in the electrical system. Otherwise the bulb failure warning light will come on. (See your Volvo dealer.)

Trailer hauling does not normally present any particular problems, but take into consideration:

- The hitch tongue load should not exceed 200 lbs (90 kgs).
- Engine and transmission are subject to increased loads.
- Avoid overload and other abusive operation.
- Hauling a trailer affects handling, durability and economy.
- It is necessary to balance trailer brakes with the towing vehicle brakes to provide a safe stop (check and observe State regulations).
- More frequent vehicle maintenance is required.
- Remove ball and drawbar assembly when the hitch is not in use.

## WARNING: do not drive with trunk lid or tailgate open!

Poisonous exhaust gases may enter via the open trunk lid or tailgate. (This is especially true for wagon models.)

If the trunk lid or tailgate for any reason must be open, proceed as follows:

- Close the windows.
- Set the heating system controls FLOOR and DEF to max. and the blower to full speed (3). See section titled "Heating and Ventilation".

## Handling, roadholding

Vehicle load, tire design and inflation pressure are important for proper handling. Therefore check that the tires are inflated to the recommended pressure according to the vehicle load.

It is recommended to use tires of the same make and dimensions on all four wheels.

### CAUTION:

Do not mix radial ply and bias ply tires as this will adversely alter the vehicle handling characteristics.

## Roof rack (removable)

- Use a sturdy roof rack, intended for the vehicle and rigidly attached. It is not advisable to let the roof rack remain in place during extended periods of time. Also, an empty roof rack increases drag and fuel consumption.
- Avoid point loads. Distribute the load evenly.
- Place the heavy cargo at bottom of load.
- Observe that center of gravity and handling are influenced by the load weight.
- Increasing load size increases wind resistance.
- Anchor the cargo correctly with a cord.
- Drive carefully. Avoid rapid starts, heavy cornering and heavy braking.
- Max. roof load is 220 lbs (100 kg).



## Air dam (front spoiler)

An air dam can negatively influence the normal flow of cooling air to the front wheel brakes. Therefore special light alloy wheel rims should be used in conjunction with the air dam. (See section titled "Wheels and tires".)

## Moisture on brake discs and brake pads affects braking

Driving in rain and slush or passing through a normal car wash can cause water to collect on the brake discs and pads. This will cause a delay in braking effect when the pedal is depressed. To avoid such a delay when the brakes are needed, depress the pedal occasionally when driving.

This will remove the water from the brakes. This should also be done after washing or starting in very damp weather.

## If the brake power assist does not function —

**The power assist to the brakes functions only when the engine is running.** When the car is moving without the engine running the brake pedal pressure required to stop the car is increased 3–4 times.

**The brake pedal feels stiff and hard.**

## Severe strain on the brake system

The brakes will be subject to severe strain when driving in mountains or hilly areas.

The speed is usually low which means that the cooling of the brake is less efficient than when driving on level roads.

To reduce the strain on the brakes it is advisable not to use the brakes excessively. Instead, shift into a lower gear and let the engine help with the braking. A good rule is to use the same gear downhill as would be used uphill. For vehicles with automatic transmission use position 2 or in some cases 1.

## If one of the brake circuits should malfunction the red warning light

**BRAKE FAILURE** will come on

(See section titled "Warning lights".)

The pedal stroke increases slightly and the pedal feels softer but the pedal pressure required does not increase noticeably.

**Drive cautiously to a Volvo dealer or Service Station to have the brake system checked.**



# Catalytic Converter

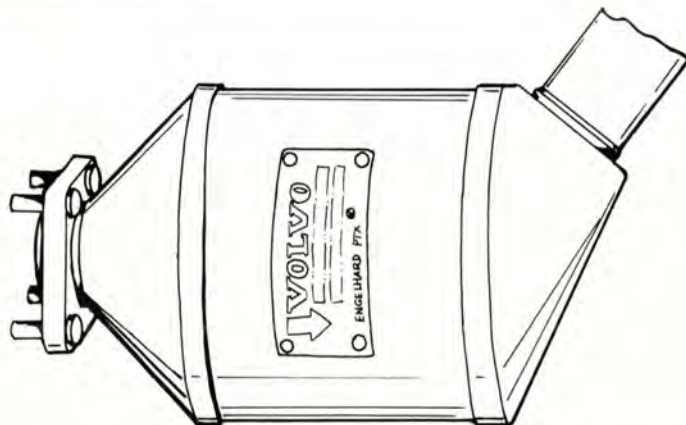

## Catalytic Converter Cautions

- Keep your engine properly tuned. Certain engine malfunctions, particularly involving the electrical, fuel or ignition systems, may cause unusually high converter temperatures. **Do not continue to operate your vehicle if you detect engine misfire, noticeable loss of power or other unusual operating conditions**, such as engine overheating, repetitive stalls or backfires. A properly tuned engine will help avoid malfunctions that could damage the Catalytic Converter.
- Remember that tampering or unauthorized modifications to the engine or the vehicle may be illegal and can cause catalyst or exhaust system overheating. This includes: Altering fuel injection settings or components. Adjusting ignition timing beyond specified limits. Altering emission system components or location or removing components.
- Do not park your car over combustible materials, such as grass or leaves, which can come into contact with the hot exhaust system and cause such materials to ignite under certain wind and weather conditions.
- Excess starter cranking (in excess of one minute) with an intermittently firing or flooded engine, can cause catalyst or exhaust system overheating. This also applies to lengthy pushing or towing of vehicle to start (manual transmission only).

**NOTE: Unleaded fuel is required for certain models. A label on the instrument panel and rear fender, near the filler inlet will remind owners and filling station attendant of this requirement. Important! It is unlawful to dispense leaded fuel into any vehicle labeled "unleaded gasoline only".**

# Maintenance

## Maintenance services

Your Volvo has passed two major inspections before it was delivered to you, according to Volvo specifications. When driven 600–1 200 miles (1 000–2 000 km) your car should be brought to the Volvo dealer for a service inspection. Engine, manual transmission and rear axle oils, will be changed at this time.

**Following this inspection, maintenance inspections as outlined in this book should be performed every 7,500 miles (12,500 km).**

The extended maintenance inspection intervals make it even more advisable to follow this program.

Inspection and service should also be performed any time a malfunction is observed or suspected.

Retain receipts for all vehicle emission services to protect your emission warranty.

See your "Warranties and Maintenance Records Manual".

## Maintenance inspection 7,500 mile (12,500 km) intervals

Volvo advises you to follow the inspection program at 7,500 mile (12,500 km) intervals which is outlined in the "Warranties and Maintenance Records Manual". This maintenance program contains inspections and services necessary for the proper function of your car over the next 7,500 miles (12,500 km). The maintenance inspections contain several checks which require special instruments and tools and therefore must be performed by a qualified technician.

To keep your Volvo in top condition, specify time tested and proven Genuine Volvo Parts and Accessories.

## THE FEDERAL CLEAN AIR ACT (USA)

The Clean Air Act requires vehicle manufacturers to furnish written instructions to the ultimate purchaser to assure the proper functioning of those components that control emissions.

The maintenance instructions listed in the "Servicing" section of this Manual represent the minimum maintenance required. These services are not covered by the warranty. You will be required to pay for labor and material used. Refer to your "Warranties and Maintenance Records Manual" for further details.

# Gas station checks

---

## Fuel

**Octane rating 91 RON for injection engines**  
**Octane rating 93 RON for carburetor engines**  
**(certain Canadian models)**

**Unleaded fuel must be used** for vehicles with catalytic converter.

Vehicles not equipped with catalytic converter can use leaded or unleaded fuel (See section on "Fuel tank cap".)

## Engine oil

Maintain oil level between the dipstick marks. The distance between the marks represents 1 quart (1 liter). Engine oil "For API Service SE" SAE 10W-40.

(See section titled "Engine oil".)

## Coolant

Maintain fluid level between MAX and MIN marks on expansion tank.

Mixture of 50 % anti-freeze and 50 % water should be used.

## Washer fluid

Washer fluid reservoir.

Water and solvent (wintertime use windshield washer anti-freeze).

## Brake fluid

Check that the level is above the MIN mark, without removing the cap.

Brake fluid DOT 4.

## Battery

Check level in conjunction with normal service or once a year.

Electrolyte level 1/4"-3/8" (5-10 mm) above plates.

Use distilled water only. **Never** add acid.

**Warning: battery gases are explosive if brought in contact with open flame or sparks.**



# Engine B 21F, B 21A

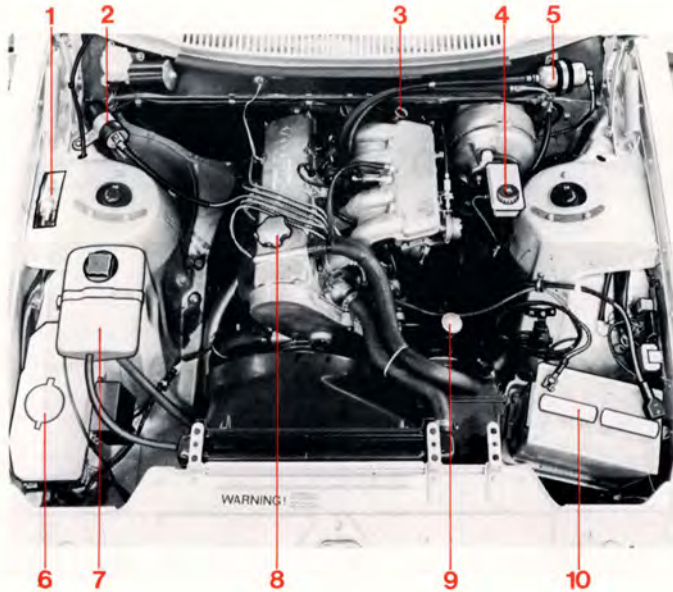

**Engine B 21F**

- |                         |                                 |
|-------------------------|---------------------------------|
| 1 Data plate            | 6 Washer fluid reservoir        |
| 2 Ignition coil         | 7 Expansion tank, coolant       |
| 3 Oil dipstick, engine  | 8 Oil filler cap, engine        |
| 4 Brake fluid reservoir | 9 Oil reservoir, power steering |
| 5 Fuel filter           | 10 Battery                      |

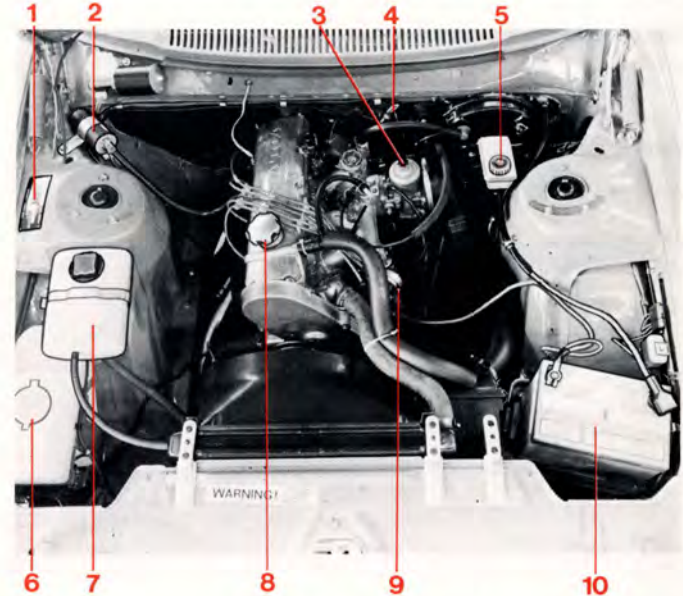

**Engine B 21A, Canada**

- |                         |                           |
|-------------------------|---------------------------|
| 1 Data plate            | 6 Washer fluid reservoir  |
| 2 Ignition coil         | 7 Expansion tank, coolant |
| 3 Carburetor            | 8 Oil filler cap engine   |
| 4 Oil dipstick, engine  | 9 Distributor             |
| 5 Brake fluid reservoir | 10 Battery                |

# Servicing

## Maintenance schedule

A = Adjust (Correct if necessary)  
R = Replace

I = Inspect (Correct or Replace if necessary)  
L = Lubricate

Maintenance Operation	miles (km)	600- 1,200 (1,000 2,000)	7,500 (12,500)	15,000 (25,000)	22,500 (37,500)	30,000 (50,000)	37,500 (62,500)	45,000 (75,000)	Description on page
<b>EMISSIONS SYSTEM MAINTENANCE</b>									
Engine Oil and Oil Filter <sup>1)</sup>		R	R	R	R	R	R	R	49
Cooling System Hoses and Connections		I							50
Engine Drive Belts		A				I			50
Torque Manifold Nuts		A							51
Valve Clearance						I			51
Camshaft Drive Belt		A						R <sup>3)</sup>	51
Vacuum Fittings, Hoses and Connections		I							51
Oxygen Sensor						R			53
Reset Service Indication for Oxygen Sensor						A			53
Air Cleaner Filter						R			53
Idle RPM		I							54
Mixture Ratio		I							54
Fuel System Cap, Tank, Lines and Connections		I							54
Spark Plugs						R			55
Ignition Timing		I							55
Catalytic Converter Mounting Bolts		A							56
Manual Transmission Oil		R	I	I	I	I	I	I	57
Automatic Transmission Oil <sup>2)</sup>		I	I	I	I	I <sup>2)</sup>	I	I	58
Rear Axle Oil		R	I	I	I	I	I	I	59

<sup>1)</sup> Oil and oil filter cartridge are first changed at the 600-1,200 mile (1,000-2,000 km) inspection. Subsequent oil and filter changes should be made at 7,500 mile (12,500 km) intervals or **at least every sixth month**.

However adverse conditions (like hot ambient temperatures, trailer hauling, hill climbing, driving long distances at high speeds, extended periods of idling or low speed operation, short trip operation at freezing temperatures) require oil changes more frequently (every third month).

<sup>2)</sup> Check the oil level (at least every sixth month). For cars used for hard driving, towing or in hilly terrain etc, perform preventive service. This includes oil changes every 30,000 miles (50,000 km).

<sup>3)</sup> Not included in emissions system maintenance but we recommend that the camshaft drive belt should be replaced every 45,000 miles (75,000 km).

## Maintenance schedule

A = Adjust (Correct if necessary)  
R = Replace

I = Inspect (Correct or Replace if necessary)  
L = Lubricate

Maintenance Operation	miles (km)	600- 1,200 (1,000 2,000)	7,500 (12,500)	15,000 (25,000)	22,500 (37,500)	30,000 (50,000)	37,500 (62,500)	45,000 (75,000)	Description on page
<b>MISCELLANEOUS MAINTENANCE</b>									
Engine Coolant						R			50
Fuel (Line) Filter				R		R			53
Carburetor, damper cylinder oil (carburetor engines)				I		I		I	54
Choke and fast idle (carburetor engines)				I		I		I	54
PCV Nipple (Orifice)									55
Ventilation Hoses									55
<b>BRAKES</b>									
Inspect Brakes. Replace components as necessary.			I			I		I	59
Change Brake Fluid <sup>1)</sup>								R	
<b>STEERING</b>									
Tire Wear (Align front end if needed.)		I	I	I	I	I	I	I	71
Check power steering fluid level.		I	I	I	I	I	I	I	59
<b>BODY</b>									
Trunk, Door and Hood Hinges and Latches		L	L	L	L	L	L	L	60

<sup>1)</sup> For cars equipped with air dam, the brake fluid should be changed every 15,000 miles (25,000 km) or once a year.



# Servicing

LAST PLUGS CHANGE

39102 8-20-85

The following items should be checked weekly by the driver. (This only takes a few moments.)	Description on page	The following should also be carried out at regular intervals.	Description on page
Engine oil level	49	Washing	77
Brake fluid	59	Polishing	77
Radiator coolant level	61	Cleaning	77
Tire pressure, all five tires	71,93	Rust protection	77
Operation of all lights	—		
Horns	—		
Windshield wipers	—		
Level of windshield fluid	—		

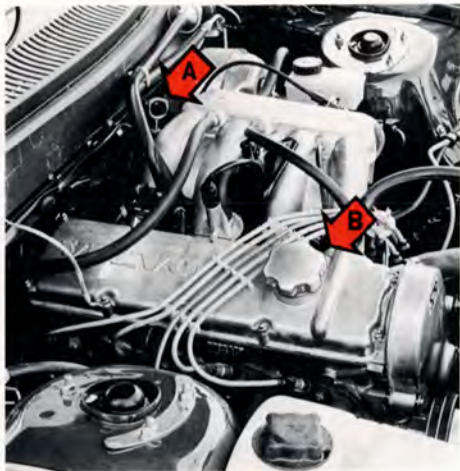

A oil dipstick

B oil filler hole

## To add or change oil

Add oil of the same kind as already used.

Capacity 4.0 US qts = 3.85 liters/3.4 Imp. qts incl. filter.

Oil type: API Service SE classification.

Viscosity:

<b>All year round</b>	SAE 10W-40
	SAE 10W-30

**Above +14°F**

(-10°C)	SAE 20W-50
---------	------------

Replace: Between first 600-1,200 miles (1,000-2,000 km) and every 7,500 miles (12,500 km) (or at least every sixth month).

At temperatures below 0°F (-18°C), multigrade oil SAE 5W-20 or SAE 5W-30 is recommended. However, this oil should not be used when the temperature is continuously above 32° F (0° C).

Driving under adverse conditions such as high ambient temperatures, trailer hauling, hill climbing, driving long distances at high speeds extended periods of idling, low speed operation or short trip operation at freezing temperatures may require oil and filter changes more frequently (every third month).

Drain the oil after driving while it is still hot.



## Changing oil filter

Replace the oil filter at every oil change. If the oil filter is changed separately 1/2 US qt = .5 liters/1/2 Imp. qt. of oil should be added.

## Checking oil level

The oil level should be checked each time the fuel tank is refilled. Be sure the oil level is maintained between the upper and lower marks on the dipstick. Low oil level can cause internal damage to the engine and overfilling can result in high oil consumption. The distance between the dipstick marks represents 1 quart (1 liter) of oil.

## Cooling system

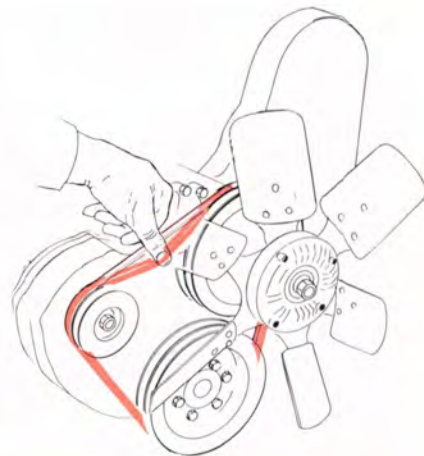
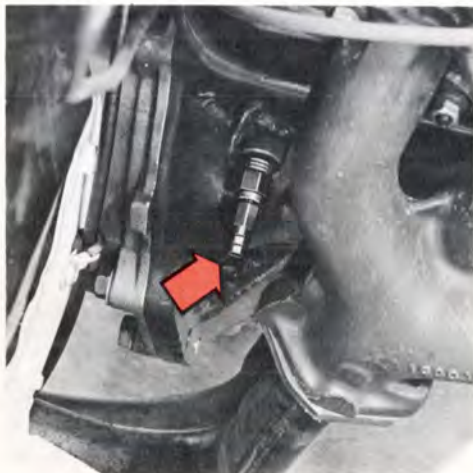

### Changing coolant

Every two years or 30,000 miles (50,000 km) the cooling system should be drained, flushed and refilled. Remove the expansion tank cap. Open the drain cock on right side of the engine block and disconnect the lower radiator hose.

**Fill coolant through the expansion tank. The heater controls should be fully open when draining and filling.**

Add coolant until the level is up to the MAX mark or slightly above.

Start engine and run until hot. Check the cooling system connections for tightness. Also re-check the coolant level.

Capacity: 9.9 US qts. = 9.4 liters/8.9 Imp. qts.

### Cooling system, hoses and connections

Check all cooling system hoses and connections for defects or deterioration of hoses and loose clamps or fittings.

### Drive belts

The belt tension can be checked by depressing the fan belt at a point midway between the alternator and fan. It should be possible to press down the belt about 1/4"–3/8" (5–10 mm). This also applies to other drive belts on the engine.



## I Engine Mechanical Components

### **Torque manifold nuts**

The manifold nuts should be torqued at the 600–1,200 mile (1,000–2,000 km) inspection. A loose manifold could alter air/fuel ratio and cause an increase in emissions and/or poor driveability.

### **Valves**

The valve clearance should be checked every 30,000 miles (50,000 km).

### **Vacuum fittings, hoses and connections**

Unstable idle, misfiring or poor emission control is often caused by leaking vacuum hoses or connections. Check hoses and connections on distributor vacuum unit, EGR valve (when applicable) and connections on heater control servo systems and hydraulic brake servo.

### **Camshaft drive belt**

The camshaft drive belt tensioner should be adjusted at the 600–1,200 mile inspection. An incorrectly tensioned drive belt will impair exhaust emissions as the valves will open and close incorrectly.

## II Engine Fuel System

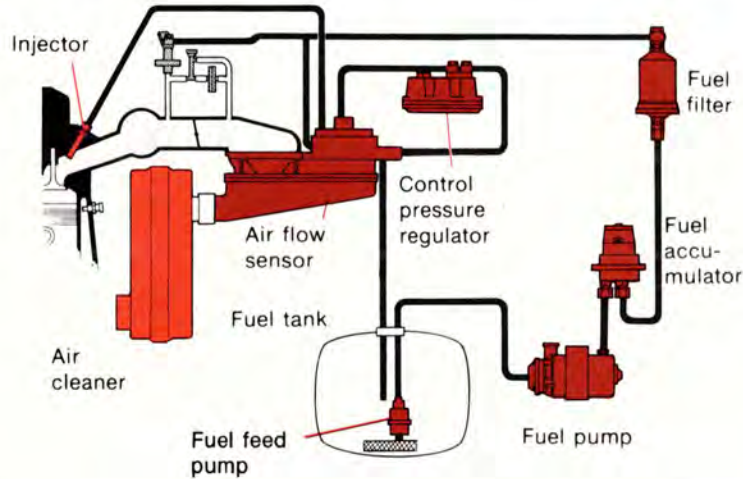

### CI system

The B21F engine is provided with a fuel injection system called the CI system (Continuous Injection). Fuel injectors are open and inject fuel as long as the engine is operating. This system has few moving parts, is reliable and meets the exhaust emission standards at maximum efficiency.

Air supplied to the engine is continuously measured and determines the amount of fuel injected.

The air flow is regulated by the throttle valve. The air flow sensor and the fuel distributor are integrally built as a single unit. A lever is actuated by the air flow to produce continuous fuel distribution.

## Special instructions for work on the fuel injection system

Extreme cleanliness is essential when working on the injection system. Great care must be observed.

Injection system service should be handled by qualified technicians, using equipment intended for this service.

## Fuel (91 octane RON)

B 21A carburetor engines for Canada require 93 octane gasoline.

Unleaded fuel permitted for all models and **required** for certain models (with catalytic converter).

A label on the instrument panel and on the rear fender, near the filler inlet, will remind of this requirement.

**It is unlawful to dispense leaded fuel into a vehicle labeled "unleaded gasoline only".**

## Lambda-sond™ (oxygen sensor) system

This is an emission control system designed to reduce emissions and improve fuel economy. An oxygen sensor monitors the composition of the exhaust gases leaving the engine. The exhaust gas analysis is fed into an electronic unit which continuously influences a frequency valve. This adjusts the air-fuel ratio to provide optimum conditions for combustion and efficient reduction of the three major pollutants (hydrocarbons, carbon monoxide and nitrous gases) by a 3-way catalytic converter.

## Change oxygen sensor unit. Reset service indication for oxygen sensor.

The oxygen sensor must be replaced every 30,000 miles (50,000 km).

To remind the driver about the change of the oxygen sensor unit there is a special reminder light. (See section titled "Warning Lights".)

The light will stay on until reset.

## Fuel (line) filter

The fuel filter is located on the firewall. We recommend that this filter should be changed every 15,000 miles (25,000 km). The filter is replaced as one complete unit.

Replace more frequently if contaminated fuel was introduced into the tank.

## Air cleaner

Replace the air cleaner cartridge with a new one every 30,000 miles (50,000 km). The cartridge should be replaced more often when driving under dirty and dusty conditions.

The filter cannot be cleaned and, therefore, should always be replaced with a new one.



# Servicing

## Checking and adjusting idling speed and mixture ratio

The idling speed should also be adjusted and the mixture ratio checked at the 600–1,200 mile (1,000–2,000 km) inspection.

## Fuel system cap, tank and lines, and connections

The effectiveness of the fuel system to contain hydrocarbons is largely dependent on a leak-free system. Check for proper sealing of gasoline filler cap which contains "O" ring type seals. Check all evaporative hoses in vehicle for tightness. Check fuel lines under vehicle and repair if necessary.



## Carburetor (Certain Canadian models)

The oil level should be up to about 1/4" (6 mm) from the edge of the center spindle. If necessary, top-up with Automatic Transmission Fluid.

**Oil quality:** Automatic Transmission Fluid

**Oil capacity:** 4,5 cc

**Oil-level check:** At 600–1,200 miles (1,000–2,000 km) and every 15,000 miles (25,000 km) thereafter.

**Oil change:** No change needed.

## Choke and fast idle

On carburetor engines, the choke and fast idle function should be checked at 600–1,200 miles (1,000–2,000 km) and every 15,000 miles (25,000 km) thereafter.

## III Engine Ignition Components

### Change spark plugs

The spark plugs should be changed every 30,000 miles (50,000 km).

However, city driving or fast highway driving may require changing after 7,500 miles of driving. When fitting new plugs, be sure to fit the right type: Engine B 21 F: Volvo Part No. 273594-2 or equivalent. Engine B 21 A: Volvo Part No. 273592-6 or equivalent. Torque to 14.5-21.7 ft lbs. (20-30 Nm).

When changing the plugs, check that the suppressor connectors are in good condition. Cracked or damaged connectors should be replaced.

When changing spark plugs, clean the cables and cable terminals, also the rubber seals. If the car is driven on roads where salt is used during the winter, coat the cables with silicone.

### Ignition timing

The ignition timing should be inspected at the 600-1,200 mile (1,000-2,000 km) inspection.

All adjusting work should be done with the proper equipment. The distributor is one of the most sensitive engine units. Careless handling can lead to decreased engine output and high fuel consumption or even serious damage to the engine.

## IV Engine Crankcase Ventilation System

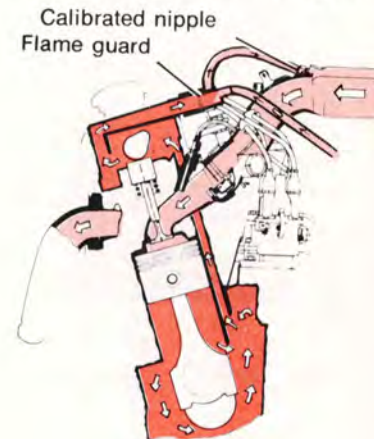

### Crankcase ventilation

The engine is provided with positive crankcase ventilation which prevents crankcase gases from being released into the atmosphere. Instead, the crankcase gases are admitted to the intake manifold and cylinders.

### Cleaning PCV valve

The calibrated positive crankcase ventilation valve should be cleaned every 60,000 miles. Rubber hoses should be checked for damage at the same time. Replace if necessary.

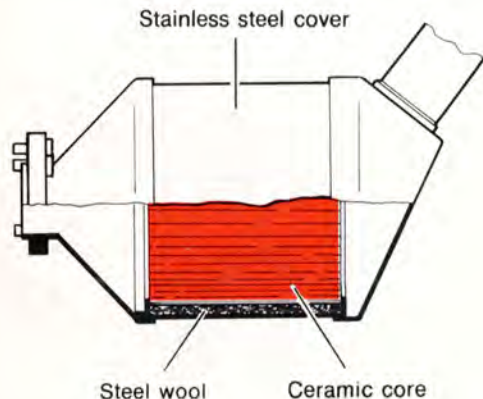

## Catalytic Converter

This is a supplementary device in the exhaust system, designed to clean the remaining dirty exhaust gases.

This device is mainly a container with a ceramic material insert, designed to let the exhaust gases pass through channels in the insert. The channel walls are covered by a thin layer of platinum and rhodium. These metals act as catalysts, permitting a chemical action to occur without actually taking part in it.

The carbon monoxide content will increase if the Catalytic Converter is damaged.

### CAUTION:

**Vehicles with Catalytic Converter must use unleaded fuel only. Otherwise the Catalytic Converter will become ineffective.**

### Torque catalytic converter mounting bolts (all U.S.A. models)

The Catalytic Converter mounting bolts should be re-torqued at the 600–1,200 mile inspection.

## VI Engine Evaporative Emissions

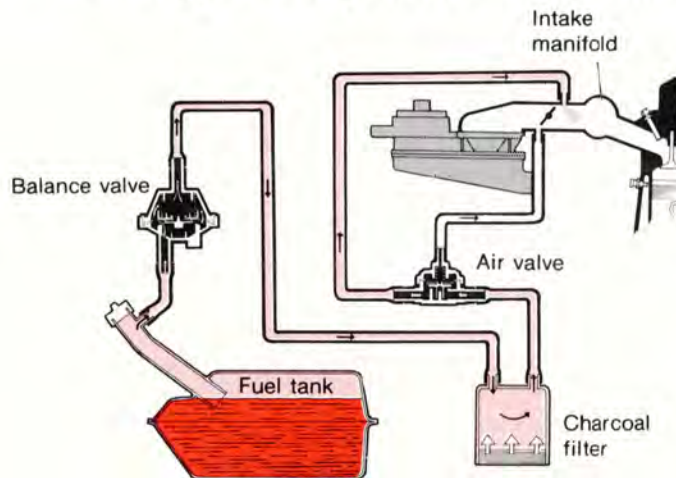

## Evaporative control systems

Vehicles intended for the North American market are equipped with a gas evaporative control system, which prevents gas fumes from being released into the atmosphere.

The system consists of an expansion area in the fuel tank, a pressure relief valve and a charcoal filter. The components are interconnected by hoses which channel fuel vapor from the gas tank to the charcoal filter where they are stored until the engine is started and then drawn into the engine fuel induction system.



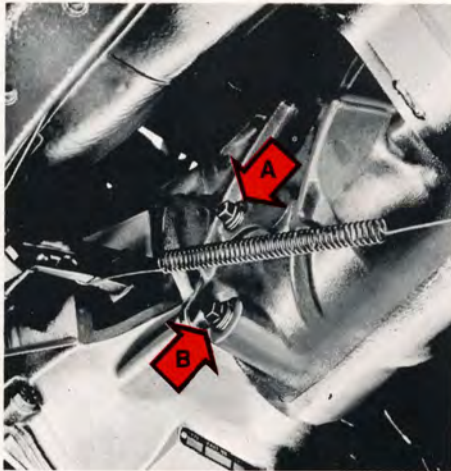

## Manual 4-speed transmission, M 45

Capacity: 0.8 US qts = 0.75 liters/0.7 Imp. qts.

Fluid type: Automatic Transmission Fluid type F or G

Replace: at 600–1,200 mile (1,000–2,000 km) service only.

The oil level should be up to the filler plug (A). Drain the oil immediately after driving, while it is still hot by removing plug (B).

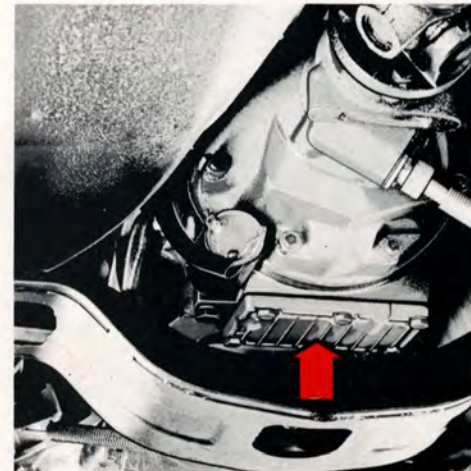

## Manual 4-speed transmission with overdrive, M 46

Capacity: 2.4 US qts = 2.3 liters/2.2 Imp. qts.

Fluid type: Automatic Transmission Fluid type F or G

Replace: at 600–1,200 mile (1,000–2,000 km) service only.

The oil level should be up to the filler plug (A).

Transmission and overdrive are lubricated by the same oil. Therefore, when the oil is drained through plug B, also remove cover on the overdrive and clean strainer.

# Transmission oil

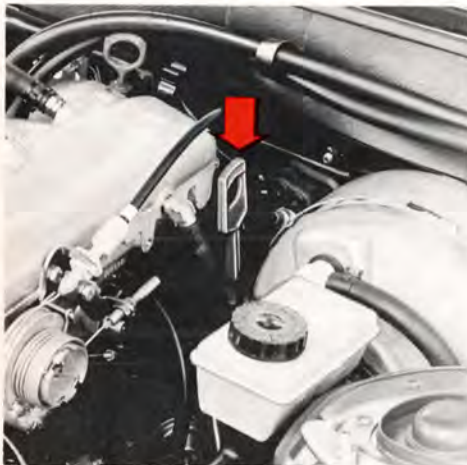

## Automatic transmission

Capacity: 7.3 US qts = 6.75 liters/6.4 Imp. qts.  
Fluid type: Automatic Transmission Fluid type F or G (FLM).  
Replace: no fluid change required under normal driving conditions.

**Check the oil level** as follows:

**Park the car on flat ground with the engine idling.**

Slowly move the selector lever through all the gear positions and then to position P. Wait 2 minutes before checking the oil level. As the illustration shows, the dipstick has a "cold" and a "warm" side.

The oil level should be between the MIN and MAX marks.

Wipe the dipstick with a clean cloth. Do not use rags which can leave lint on the dipstick. **CAUTION!** The oil or dipstick may be very hot!

The transmission is topped-up via the tube in which the dipstick sits. The space between the MIN and MAX marks on the dipstick corresponds to 0.5 liter. Do not fill the transmission with too much oil, since this can result in oil being ejected from the transmission.

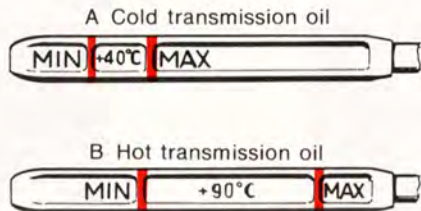

Early 1980 production models may have a dipstick which differs from that described previously (see illustration).

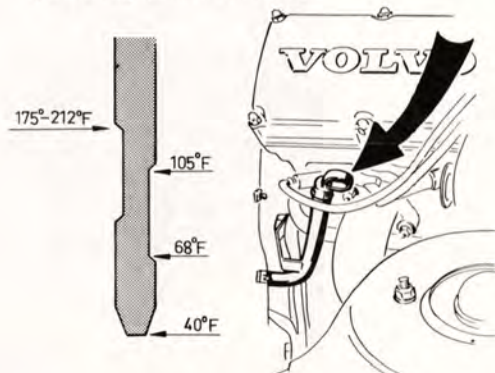

Too little oil, on the other hand, can negatively affect transmission operation particularly in very cold weather.

**A Cold gearbox oil – oil temperature +40° C (105° F)**

This is a normal temperature for the transmission after idling for about 10 minutes.

At oil temperature below +40°C, the level may be below the MIN mark.

**B Warm gearbox oil – oil temperature +90° C (190° F)**

This temperature is obtained when driving for about 30 minutes. At oil temperatures above +90°C, the level may be above the MAX mark.



# Rear axle, power steering, brake fluid

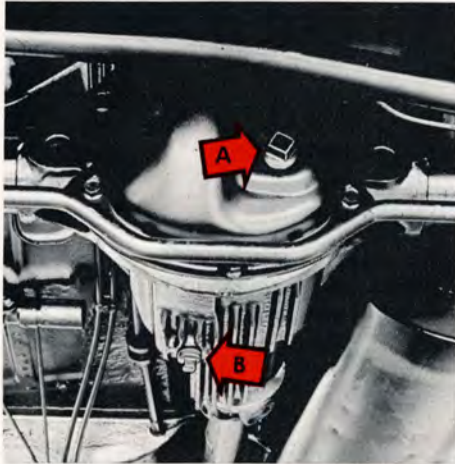

## Rear axle

Capacity: 1.7 US qts = 1.6 liters/1.4 Imp. qts.  
Oil type: API GL-5 (MIL -L-2105 B or C)  
Viscosity: SAE 90  
Replace: at 600-1,200 mile (1,000-2,000 km) service only.

The oil level should be up to the filler plug (A). Drain rear axle oil through drain plug (B). When the temperature is steadily below 15° F (-10° C) use API GL-5 SAE 80W/90 oil. Cars equipped with limited slip differentials should use oils with proper additives.

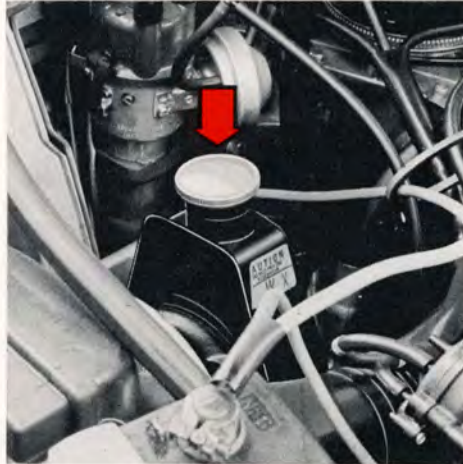

## Power steering

Capacity: 0.8 US qts = 0.75 liters/0.7 Imp. qts.  
Fluid type: ATF  
Replace: no fluid change required.

The level should be between the MAX and MIN marks. Check fluid level with engine idling and after driving while the fluid still is hot. Wipe the reservoir clean.

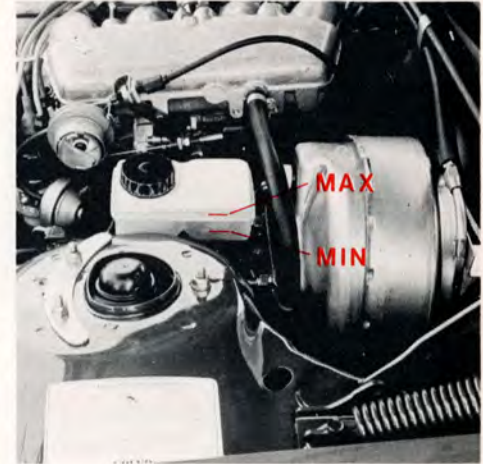

## Brake fluid

Fluid type: DOT 4  
Replace: every third year or 45,000 miles (75,000 km).

Check, without removing the cap, that the level is above the "MIN" mark of the fluid reservoirs. Always entrust brake fluid changing to a Volvo dealer.

Change brake fluid every year when driving under extremely hard conditions (mountain driving, etc.) and if the car is equipped with an air dam!



# Lubrication



## Chassis maintenance

To simplify maintenance, your Volvo has been equipped with ball joints, steering rods and propeller shafts that do not require regular lubrication.

Points that normally require lubricating have been packed with very durable grease at the factory and then carefully sealed, eliminating the need for subsequent lubrication.

## Lubricate body

To avoid rattles and unnecessary wear, the body should be lubricated once a year. Hinges on hood, doors and trunk lid as well as door stops should be lubricated every 7,500 miles (12,500 km). During winter, locks in the doors and trunk lid should be treated with special anti-freeze lubricant to prevent freezing.

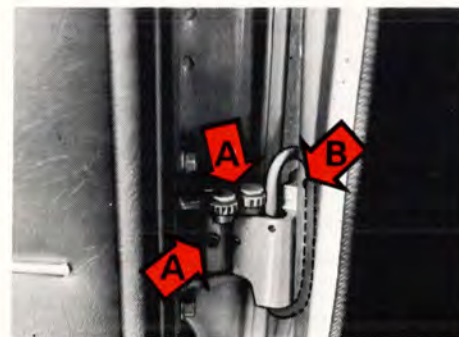

**Door hinges (lower) and door stop**

A grease  
B oil

No.	Lubricating point	Lubricant
1	Hood lock	Paraffin wax
2	Hood hinges	Oil
3	Door hinges (upper)	Grease
4	Sunroof wind deflector	Oil
5	Door lock outer sliding surfaces	Paraffin wax
6	Trunk lid hinges	Oil
7	Trunk lid lock	Lock oil
8	Door hinges (lower)	Grease
	Door stop	Oil
9	Window regulator	Oil, grease
	Locking device (Accessible after door upholstery panels removed)	Silicon grease
10	Front seat slide rails and latch devices	Oil
11	Key holes	Lock oil
12	Striker plate	Paraffin wax



## Check coolant level

The cooling system must be filled with coolant and not leak to operate at maximum efficiency. Check the coolant level when filling fuel. The level should be between the "MAX" and "MIN" marks on the expansion tank. The check should be made with particular thoroughness when the engine is new or the cooling system has been drained.

Do not remove the filler cap other than for topping-up with coolant. Frequent removal may prevent coolant circulation between the engine and the expansion tank during engine warming up and cooling.

## Top up with coolant

Top up with coolant by filling the expansion tank when level is at the "MIN" mark. Use a mixture of 50 % anti-freeze and 50 % water all the year round. Top up to the "MAX" mark. If the engine is warm, and you are going to top up coolant, unscrew the cap slowly in order to allow any excess pressure to escape.

**NOTE:** Do not top up with water only. Water by itself reduces the rust-protective and anti-freeze qualities of the coolant and has a lower boiling point. It can also cause damage to the cooling system if it should freeze.



## Alternator, jump starting

### This car is equipped with an alternator

When changing the battery or when carrying out work involving the electrical system, the following should be observed.

- 1 A battery connection to the wrong terminal will damage the diodes. Before connections are made, check the polarity of the battery with a voltmeter.
- 2 If booster batteries are used for starting, they must be properly connected to prevent the diodes from being damaged. For correct connection, see next section, titled "jump starting".
- 3 If a fast charger is used for charging the battery, the battery leads should be disconnected.
- 4 Never disconnect the battery circuit (for example, to change the battery) while the engine is running, as this will immediately ruin the alternator. Always make sure that all the battery connections are properly tightened.
- 5 If any electrical welding work is performed on the vehicle, the ground lead and all the connecting cables to the alternator must be disconnected and the welder wires placed as near the welding point as possible.

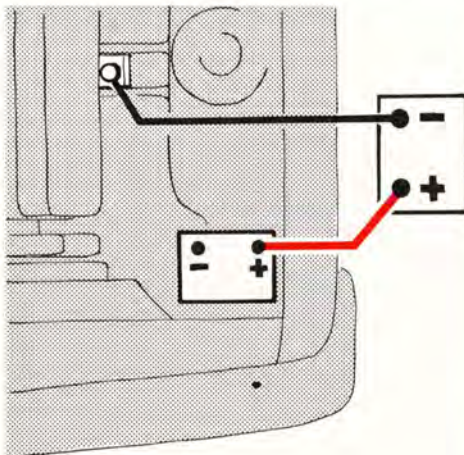

### Jump starting

**CAUTION: Improper hook-up of jumper cables could result in damage to equipment and/or battery.**

Check that cars are not touching. (To prevent premature completion of negative circuit). Using jumper cables, first connect booster battery positive terminal (+) to car battery positive terminal(+). Then connect booster battery negative terminal (-) to a stationary solid metal part on the engine at a point away from the battery. Do not connect to any part of fuel system or any moving parts. Avoid touching hot manifolds.

### WARNING

To prevent possible explosion, never expose battery to open flame or electric spark. Do not smoke near battery. Batteries generate Hydrogen gas which is flammable and explosive. Battery fluid contains sulfuric acid. Do not allow battery fluid to contact eyes, skin, fabrics or painted surfaces. If contact occurs, flush affected area immediately with water. Seek medical attention if eyes are affected.

After engine has started remove negative terminal (-) jumper cable first then positive terminal (+) jumper cable.



## Replacing bulbs

The replacement of bulbs in the various lighting units is shown on the following pages. Make sure when installing bulbs, that the guide pin on the socket fits into its corresponding recess.

When installing bulbs, do not touch the glass with your fingers. The reason for this is that grease, oil or any other impurities can be carbonized onto the bulb and damage the reflector.

Use bulbs of correct type and voltage. Failure to do so could activate the bulb failure warning light.

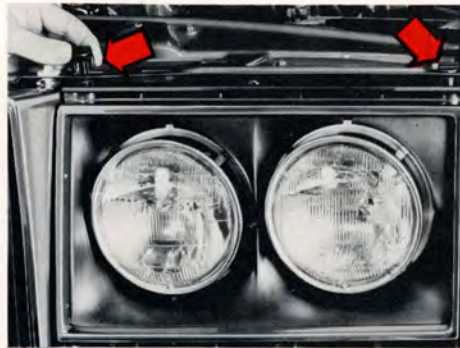

1



2

## Round twin headlights, 4 and 5 door DL models (and 4 door GL models for Canada)

- 1 Press the two plastic screws down and turn them 1/4 turn and remove them.
- 2 Lift up the rim slightly and remove it forwards.
- 3 Remove clip and ring. Lift out the headlamp unit.
- 4 Disconnect the socket contact.

Installation is done in the opposite way.

Check that chromed ring is retained by all four clips.



3



4

**Check headlight alignment.**

## Replacing bulbs

### Square twin headlights, 4 and 5 door GL models

- 1 Press the two plastic screws down and turn them 1/4 turn and remove them.
  - 2 Lift up the rim slightly and remove it forwards.
  - 3 Remove the Phillips screws and rim. Lift out the headlamp unit.
  - 4 Disconnect the socket contact.
- Installation is done in the opposite way.

**Check headlight alignment.**

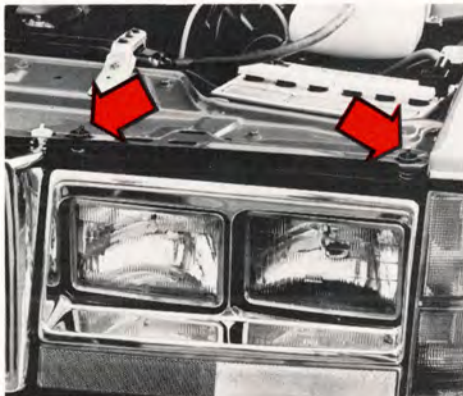

1

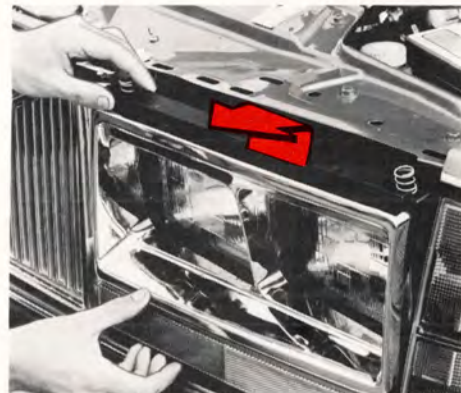

2

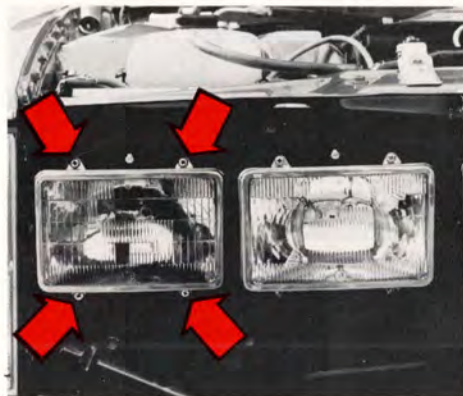

3

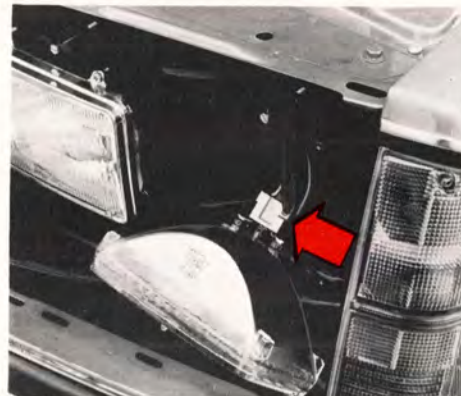

4



### Single round headlights, 2 door models

1 Press the two plastic screws down and turn them 1/4 turn and remove them.

2 Lift up the rim slightly and remove it forwards.

3 Turn the chromed ring slightly counter-clockwise. Remove the chromed ring and lift out the headlamp unit.

4 Disconnect the socket contact.

Installation is done in the opposite way. Check that the chromed ring is retained by all four clips.

**Check headlight alignment.**

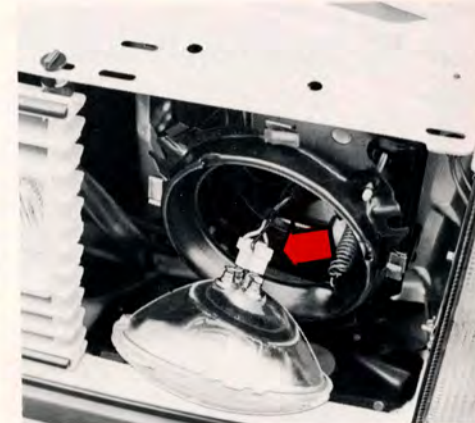
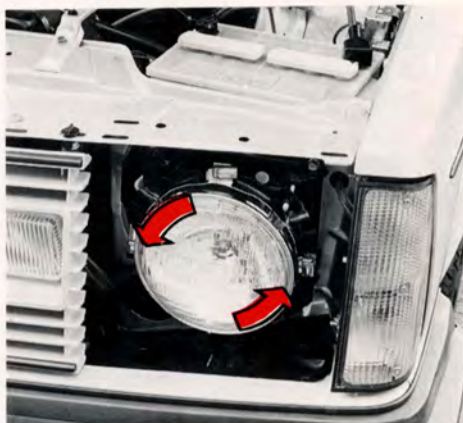
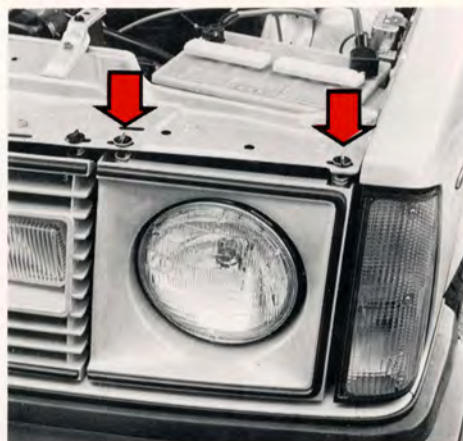



## Replacing bulbs

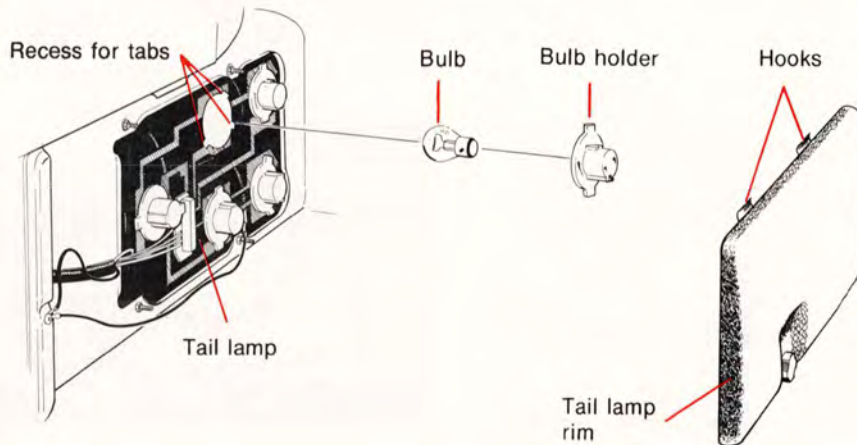
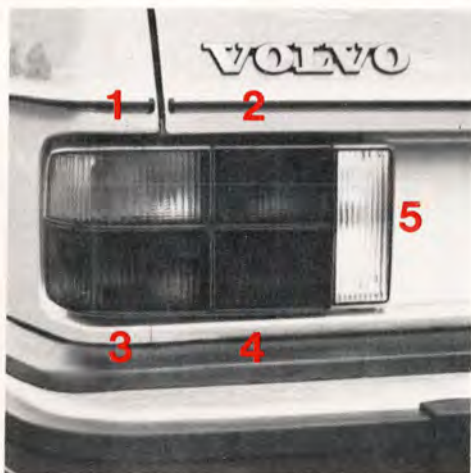

### Tail lamp 2 and 4 door models

Bulbs	Power CP/W	Socket	US bulb No
1 Rear turn signal	32/21	BA 15 s	1073
2 Stop light	32/21	BA 15 s	1073
3 Tail light, side marker light	4/5	BA 15 s	67
4 Tail light	4/5	BA 15 s	67
5 Back-up light	32/21	BA 15 s	1073

All tail lamp bulbs are replaced from inside of trunk.

- 1 Unscrew and remove tail lamp rim. Note that rim is hooked at the upper edge. Lift the lower end out/up and unhook upper edge.
- 2 Turn bulb holder approx. 3/8" counterclockwise and remove it.
- 3 Depress bulb in bulb holder, turn it slightly counterclockwise, and remove it.
- 4 Install a new bulb. Install bulb holder in tail lamp.

**NOTE:**

One of the bulb holder tabs is wider and fits only in corresponding recess.

Turn bulb holder clockwise. Check that bulb illuminates. Replace tail lamp rim.

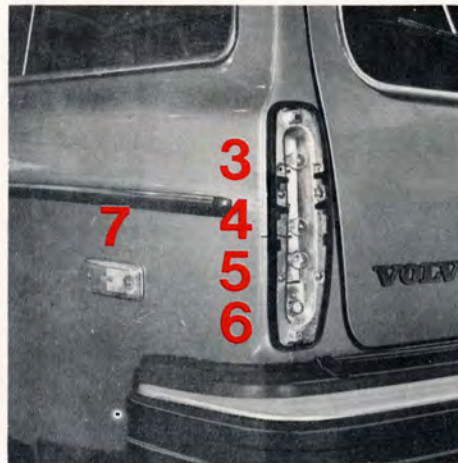
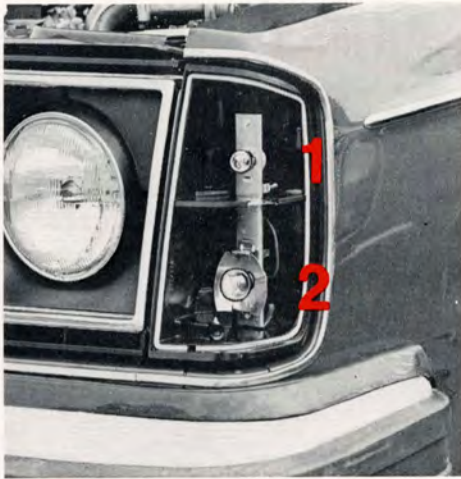

## Front light bulbs

Loosen the Phillips screws and remove the lens. The bulbs can now be removed by pressing them inwards and turning them slightly counterclockwise.

Bulbs	Power CP/W	Socket
1 Front position, Side marker lights	4/5	Ba 15 s*
2 Front turn signal	32/21	Ba 15 s**

\* US Bulb No 67

## Tail lamp bulbs, Wagon model

Loosen the Phillips screws and remove the lens. The bulbs can now be removed by pressing them inwards and turning them slightly counterclockwise.

Bulbs	Power CP/W	Socket
3 Rear turn signal	32/21	Ba 15 s**
4 Back up light	32/21	Ba 15 s**
5 Stop light	32/21	Ba 15 s**
6 Tail light	4/5	Ba 15 s*
7 Side marker light	2/4	Ba 9 s***

\*\* US Bulb No 1073

\*\*\* US Bulb No 57

## Side marker light bulbs (Wagon)

Remove the two Phillips screws which hold the lens. The bulb can now be removed by pressing it inwards and turning it slightly counterclockwise.

## Replacing bulbs

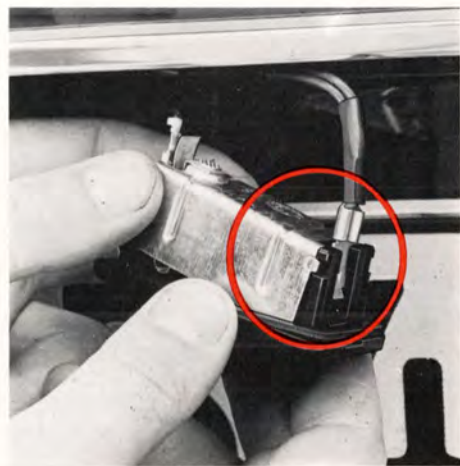
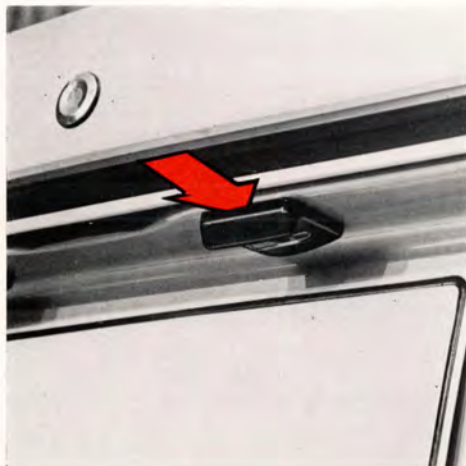

### License plate light, 2 and 4 door models

Insert a screwdriver as shown and carefully pry loose the lamp housing. Take care not to damage the paint. Pull out the lamp housing and replace the bulb. Insert the front edge of the lamp housing and press up the rear edge by the hand.

Bulbs	Power	Socket
License plate light	4W	Ba 9 s

### License plate light, Wagon model

Insert a screwdriver through the opening in the housing and depress the catch tab. Pull down the housing assembly.

Pull out the cover end which is not provided with a lock pin.

Replace bulb.

When re-installing, first locate the lock pins (see picture) and then press on the cover. Check that the rubber gasket is positioned and press the housing assembly into place.

Bulbs	Power	Socket
License plate light, Wagon	5 W	S 8.5 8



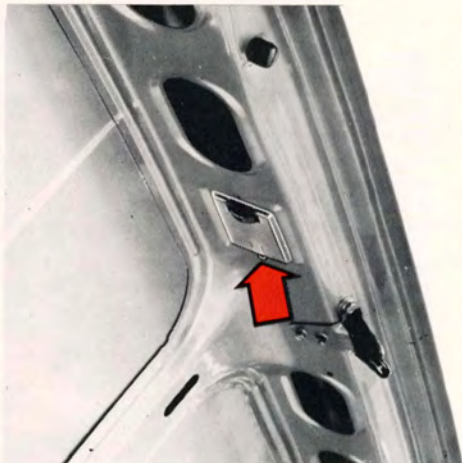

## Trunk light 2 and 4 door models

Remove screw holding light assembly. Lift out end to the right to remove.

Replace bulb.

Reinstall by first inserting the guides into the left side then press in the light assembly and install screw.

Bulb	Power	Socket
Trunk light	15 W	S 8.5 8



## Interior light

Insert a screwdriver through the opening in the right side of the housing and depress the catch tab. Pull down the housing assembly and replace the bulb.

## Replacing bulbs for Instrument lighting and heater control lighting

Due to the location of the bulbs, their replacement should be carried out by a Volvo dealer.

# Fuses

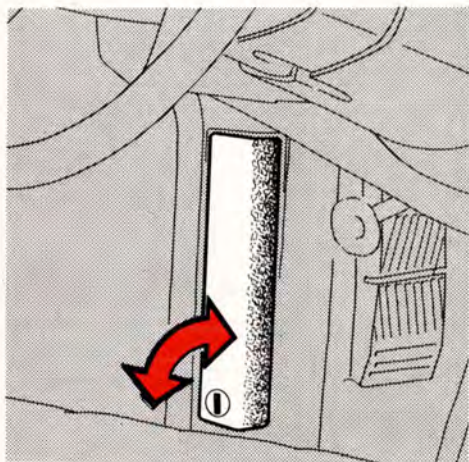

## Replacing fuses

The fuse box is positioned in front of the left front door pillar.

When replacing fuses, check that right amperage is used.

**Never** use fuses of higher amperage. If one fuse repeatedly fails take the car to your Volvo dealer for fault-tracing.

Reading downwards the fuses protect the following:



- |    |  |     |
|----|--|-----|
| 1  | Lighter<br>Tailgate window wiper<br>El. side view mirrors (optional)   | 8A  |
| 2  | Windshield wiper/washer<br>Horn  | 16A |
| 3  | Heater fan   | 16A |
| 4  | Seat belt warning and<br>Ignition key buzzer   | 8A  |
| 5  | Fuel pump (feed pump)  | 8A  |
| 6  | Brake light<br>Relay, interior light   | 8A  |
| 7  | Fuel pump (main pump)  | 16A |
| 8  | Interior light<br>Glove compartment light<br>Clock<br>Trunk light<br>Engine compartment light<br>Central locking<br>El. radio antenna (optional) | 8A  |
| 9  | Hazard   | 8A  |
| 10 | El. op. window (optional)  | 16A |
| 11 | Overdrive<br>Rear window demister  | 16A |
| 12 | Back-up light<br>Relay, el. op. window<br>El. heated driver seat (Canada)<br>Air conditioning (optional)   | 8A  |
| 13 | Instruments<br>Turn signals<br>Relay fuel injection<br>Seat belt warning   | 8A  |
| 14 | Spare  |     |
| 15 | Left parking light<br>License plate light<br>Side marker light (wagon)   | 8A  |
| 16 | Right parking light<br>Instrument and panel light<br>Buzzer head lights  | 8A  |
| 17 | Fuse storage, spare  |     |



## Checking and correcting tire pressure

Check the tire pressure when refueling. The tire pressure should only be corrected when the tires are cold. With warm tires, correct only when the pressure is too low. The tire temperature rises after driving just a few miles.

## Tire pressures, cold tires, psi (kPa)

Increase the tire pressure 30 kPa = 4 psi if driving at high speeds for extended periods of time (more than one hour at speeds in excess of 70 mph = 115 km/h).

Car model	Vehicle capacity weight, lbs (kgs)	Tire	Recommended inflation pressure psi (kPa)						
			Normal speed				>75 mph (120 km/h)		
			1-3 persons		Full load				
			Front	Rear	Front	Rear	Front	Rear	
2/4 door models	DL	920(420)	175 R 14	26(180)	27(190)	26(180)	32(230)	30(210)	36(250)
		920(420)	DR 78-14	26(180)	28(200)	26(180)	32(230)	26(180)	32(230)
	GL	920(420)	185/70 R 14	26(180)	27(190)	28(200)	32(230)	28(200)	32(230)
	GT	920(420)	195/60 R 15	26(180)	27(190)	28(200)	32(230)	28(200)	32(230)
	"Special Spare"			32(230)	32(230)	32(230)	32(230)	**	**
Wagon models	DL	1120(520)	DR 78-14	26(180)	30(210)	26(180)	32(230)	*	*
	DL, GL	1120(520)	185 R 14	27(190)	30(210)	28(200)	36(250)	28(200)	36(250)
	"Special Spare"			40(280)	40(280)	40(280)	40(280)	**	**

\* Max 75 mph (120 km/h)  
 \*\* Max 50 mph (80 km/h)

## Examples of tire wear

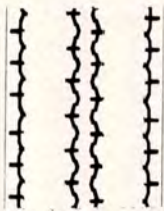

Underinflated

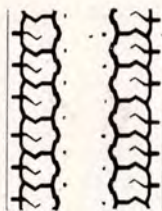

Overinflated



Wrong toe-in

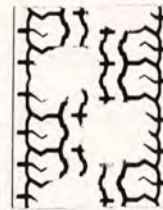

Unbalance

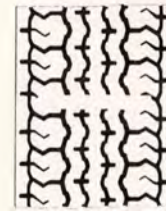

Wear indicator exposed  
Tire is worn, replace



# Wheels and tires

---

## Wear indicator

The tires have a so-called "wear indicator" in the form of a number of narrow strips running across or parallel to the tread. When approx. 1/16" = 1.5 mm is left on the tread, these strips show up and indicate the tire should be replaced.

Tires with less than 1/16" tread have a very poor grip in rain or snow.

## How to improve tire economy

- Maintain correct tire pressure.
- Drive smoothly: avoid fast starts, hard braking and tire screeching.
- Tire wear increases with speed.
- Do not change wheel location unless necessary.
- Correct front wheel alignment is very important.
- Unbalanced wheels impair tire economy and driving comfort.
- Hitting curbs can damage the tires permanently.

## Snow tires

Radial snow tires are recommended for winter use.

Tire **Chains** can be used on the rear wheels only providing that the chains do not project far enough from the tire that they can chafe against the brake caliper or other components.

**Strap-on emergency chains must not be used since the space between the brake calipers and wheel rims does not allow sufficient clearance.**

## WARNING

### Air dam

An air dam can negatively influence the normal flow of air to the front wheel brakes. Therefore, special light alloy wheel rims or steel wheel rims of 1980 year model + ventilated brake disks at the front wheels should be used in conjunction with the air dam.

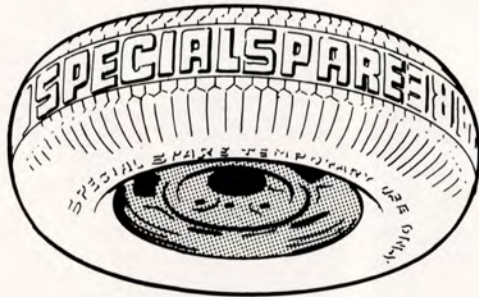

## **WARNING!**

It is recommended that the "Special Spare" be used only as a temporary replacement for a punctured tire. It must be replaced as soon as possible by a standard tire.

Note that roadholding, etc. may be affected with the "Special Spare" installed.

Do not drive at speeds in excess of 50 mph (80 km/h)!

## **Special Spare**

The spare wheel for your car is referred to as a "Special Spare". This name is embossed on the tire, see illustration.

On 2- and 4-door models, the "Special Spare" wheel contains a 4 ply rating tire and on the wagon models an 8 ply rating tire.

Tire pressure must be 32 psi (230 kPa) on a 4 ply rating tire and 40 psi (280 kPa) on a 8 ply rating tire irrespective of load or where the wheel is installed.

In the event of a damage to this tire a new one can be purchased from your Volvo dealer.

## Wheel changing



### Changing a wheel

Spare wheel, jack and tool kit are stowed in the trunk compartment. Before raising the car with the jack be sure it is on firm and level ground.

**NOTE: Do not crawl or work under the car while it is raised by the jack.**

Before the car is raised with the jack the parking brake should be applied and one of the gears engaged. With automatic transmission, the selector should be in **Park**. Block one of the wheels on the opposite side of the car from the jack.

### Note:

To avoid excessive tire wear and rebalancing, mark and reinstall wheels in same location and position as before removal.

### Removal

To remove the wheel cap the center emblem must first be pried-off using the screwdriver provided in the tool kit. The wheel cap may then be removed by hand. The GT has no wheel cap. Loosen the wheel nuts 1/2-1 turn with the box wrench provided in the tool kit. All of the wheel nuts have right-hand threads which are loosened by turning them counterclockwise.



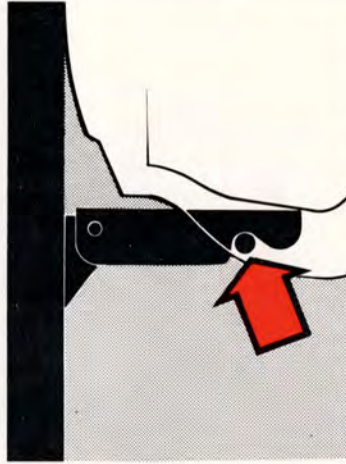

2 and 4 door models



Wagon models

Insert the lifting arm of the jack in the jack attachment closest to the wheel to be changed.

**Be sure the arm goes all the way into the attachment.**

Raise up the side of the car enough to lift the wheel off the ground.

## WARNING!

- Be sure the jack is on firm and level ground.
- Never crawl under a car supported by a jack.
- Use the jack intended for the car when replacing a wheel. For any other job use stands to support the end of the car being worked on.
- Apply the parking brake, engage first or reverse gear (pos. P for cars equipped with automatic transmission).
- Chock the wheels standing on the ground. Use rigid wooden blocks or large stones.

Unscrew the wheel nuts completely and remove the wheel carefully so as not to damage the threads of the studs.

## Installation

- Clean the nuts and the contact surface between wheel and hub.
- Lift on the wheel and fit the wheel center on the hub shoulder.
- Tighten the nuts until the wheel makes good contact with the flange.
- Lower the car and tighten the nuts alternately to 72–100 ft.lbs. (100–130 Nm).
- Fit the wheel cap.

**NOTE: Do not rotate a raised rear wheel if the car is equipped with a limited slip differential. This will also move the opposite wheel on the ground and the car may slide off the jack.**

## Replacing wiper blades

---

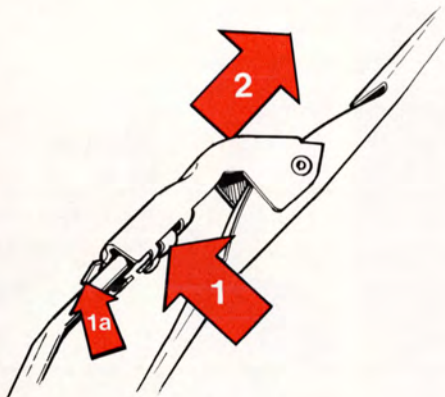

### Replacing wiper blades

Fold the wiper arm outward. Press in the shiny lock spring on the wiper arm backside (1). (Or use a screwdriver to bend up the thin shiny sheet metal tab on the wiper arm front side, 1 a). Pull out the wiper blade (2). Push on the new wiper blade and **check for correct attachment.**

#### **NOTE:**

For improved driving safety replace the wiper blades when they start to wipe inefficiently.



## Washing

The car should be washed at regular intervals since dirt, dust, insects and tar spots adhere to the paint and may cause damage.

When washing the car, do not expose it to direct sunlight. Use lukewarm water to soften the dirt before you wash with a sponge, and plenty of water, to avoid scratching.

A detergent can be used to facilitate the softening of dirt and oil.

Special car washing detergent or household detergent can be used. A suitable mixture is about 2.5 fl. oz. (approx. 8.5 cl) of detergent to 2.6 US gal. = 10 liters/2.2 imp. gal. of warm water. After washing with a detergent the car should be well rinsed with clean water.

A water soluble grease solvent may be used in cases of sticky dirt. However, use a washplace equipped with a drainage separator.

Dry the car with a clean chamois and remember to clean the drain holes in the doors and rocker panels.

Tar spots can be removed with kerosene or tar remover after the car has been washed.

**NOTE:** It is particularly important to wash the car frequently in the winter time, to prevent corrosion, when salt has been used on the roads.

### **NOTE:**

**When the car is driven immediately after being washed, brake the car now and again in order to remove any moisture from the brake linings.**

## Chromed parts

Chromium-plated and anodized parts should be washed with clean water as soon as they become dirty. This is particularly important if you drive on gravel roads or on roads where salt is used during the winter. After the car has been washed, apply wax or an anti-rust preparation.

Stains on chrome trim can be removed with commercially available chrome cleaner. Do not use abrasive compounds or steel wool.

## Polishing (waxing)

Polishing and waxing is not necessary unless a glossy surface can no longer be obtained by normal car washing.

Normally, polishing is not required during the first year after delivery, however, waxing may be beneficial.

Before applying polish or wax the car must be washed and dried. Tar spots can be removed with kerosene or tar remover. Difficult spots may require a fine rubbing compound. After polishing use liquid or paste wax.

Several commercially available products contain both polish and wax. Waxing alone does not substitute for polishing of a dull surface.

## Cleaning the upholstery

Generally the **fabric** can be cleaned with soapy water or a detergent. For more difficult spots caused by oil, ice cream, shoe polish, grease, etc., use a stain remover.

The **Plastic** in the upholstery can be washed. To clean **leather upholstery**, use soft cloth

and mild soap solution, for instance common toilet soap.

For more difficult spots, consult an expert for the choice of cleaning agent.

**On no account must gasoline, naphtha or similar cleaning agents be used on the plastic or the leather since these can cause damage.**

When aging, leather changes appearance, but the typical texture remains. To preserve smoothness and appearance, it is recommended to treat the leather with a special leather preservative after one or two years of use.

## Cleaning floor mats

The floor mats should be vacuumed or brushed clean regularly, especially during the winter when they should be taken out for drying.

Spots on textile mats can be removed with a mild detergent.

## Anti-rust treatment

Your Volvo has been rust protected at the factory. On external surfaces a heavy coat of wear resistant material has been used, while on the internal surfaces a lighter rust protector is used.

The external rust protection should be inspected regularly or at least once per year. If the rust protection has been penetrated a repair should be made as soon as possible to prevent moisture from entering between the metal and coating. Carefully clean and remove any rust prior to repair of the rust protective coating.

The internal rust protection should normally be renewed first time after 36 months and then at least every 24th month.



# Paint touch-up

## Paint touch-up

Paint damage requires immediate attention to avoid rusting. Make it a habit to check the finish regularly, for instance when washing the car. Touch-up if necessary.

Paint repairs require special equipment and skill. Contact your Volvo dealer for any extensive damages.

Minor scratches can be repaired by using Volvo touch-up paint.

**NOTE:** When ordering touch-up paint from your Volvo dealer, use the paint code indicated on the service label. This plate is located on the plate in front of the radiator in the engine compartment.

### Paint code

VERSION	MARKET TYPE	ALTERNATIVE	OPTION
PAGE	COLOUR	KLADSEL	UPHOLSTERY
BRONZE PEARL			
BRAKES FRONT			
BRAKES REAR			
FORGASJÄRE			
CARBURETTOR			
NOJSLÄMPOR			
FUEL PUMP			
		KOPPLING	CLUTCH
		GENERATOR	DYNAMO
		STYRNING	STEERING-GEAR
<b>VOLVO</b>			
124668			

## Minor stone chips and scratches

Material:

Rust remover

Primer – brush on type

Surface finish – brush on type

(The paint pen head also contains grinding paste for subsequent treatment).

Penknife or similar

Brush

NOTE: When touching-up the car, it should be well cleaned and dry and have a surface temperature above + 15°C (60°F).

**Scars on the surface** (where the paint has not been completely penetrated). Repairs can be made directly after light scraping to remove dirt.

**Deep scars, (down to the bare metal):**

1 Scrape or sand the damaged surface lightly and break the edges of the scar.

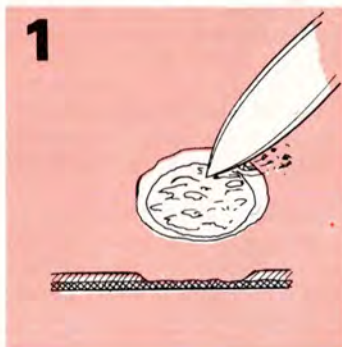

- 2 Apply the rust remover. (Avoid contact with eyes and skin!). Wait a few minutes and then rinse carefully with water and wipe dry.
- 3 Thoroughly mix the primer and apply it with a small brush.



- 4 When the primer surface is dry, the paint can be applied using a brush. Mix the paint thoroughly, apply several thin paint coats and let dry after each application.

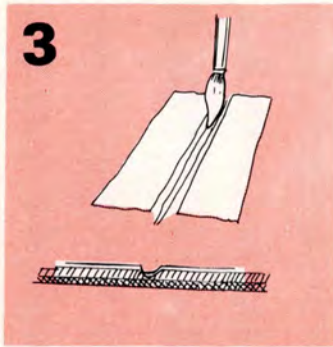

- 5 If there is a longer scratch, you may want to mask to protect surrounding paint.

## Touching-up damaged paint on fender edges and sills

Material:  
Rust remover  
Primer – spray  
Surface finish – spray  
Sand paper (H 150 – 300 grit)  
Thinner

**NOTE:** When touching-up the car, it should be well cleaned and dry and have a temperature exceeding +15°C (60°F).

**NOTICE!** Spray paint may contain saturated chlorofluorocarbon propellant, sale of which may be illegal in certain areas.

Mask with tape and paper prior to painting larger surfaces. Remove the masking immediately after application of the last paint coat, before the paint starts to dry.

Touching-up is as follows:

- 1 Remove paint flakes.
- 2 Sand the damaged surface and wash it clean with thinner.  
Apply the rust remover. (Avoid contact with skin!) Wait a few minutes and then rinse carefully with water and wipe dry.
- 3 Shake the spray can for at least 1 minute. Spray on the primer. Move the can slowly and evenly back and forth over the spot and about 20–30 cm (8–12 in.) from the surface. Protect the surrounding surfaces with suitable paper.

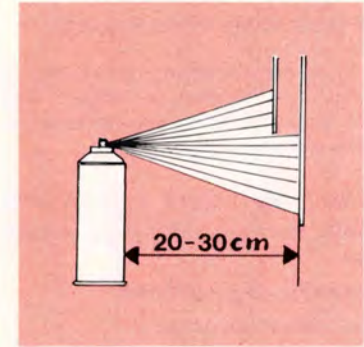

- 4 When the primer has dried, apply the surface enamel in the same way. Spray on several times and allow the paint to dry a minute or so between each application.

# Long distance trips

---

## Prior to a long distance trip

Have your car checked at a Volvo dealer. Preventive maintenance will help to ensure a trouble free trip. Remember to take along a Volvo dealer directory.

The main items to check are listed below:

- 1 Brakes, front wheel alignment and steering gear.
- 2 Engine running condition.
- 3 Fuel system operation.
- 4 Oil leaks: engine, transmission, rear axle.
- 5 Cooling system for leaks or worn hoses.
- 6 Examine tires carefully, replace worn tires.
- 7 Battery and terminals.
- 8 Tool equipment.
- 9 Lighting.
- 10 Drive belts for tightness and wear.
- 11 Check fluid levels.



## Engine cooling system

A good quality anti-freeze/summer coolant should be used all the year round. The cooling system should always contain water plus anti-freeze and rust inhibitor, even during the summer. Experience has also shown that extremely weak anti-freeze solutions (10–25%) are ineffective for rust protection. For this reason, the quantity of anti-freeze/summer coolant should amount to about 50% of the solution, that is 5.0 US qts=4.8 liters/4.3 Imp qts. This lowers the freezing point to  $-30^{\circ}\text{F}$  ( $-35^{\circ}\text{C}$ ). Alcohol must not be used as an anti-freeze agent since it evaporates at normal engine temperature.

## Engine fuel system

During the winter, large variations in temperature causes condensation to form in the fuel tank and can impair the running of the engine. This can be eliminated by adding special additives to the fuel. There is less risk of condensation forming in the fuel tank if it is kept full.

## Engine lubricating system

During the winter, multigrade oil 10W-40 should be used in the engine. At very low temperatures, below  $0^{\circ}\text{F}$  ( $-20^{\circ}\text{C}$ ), multigrade oil SAE 5W-20 or SAE 5W-30 is recommended. These oils reach the lubricating points in the engine more easily at low temperature and also facilitate cold starting. See section titled "Engine Oil".

## Electrical system

The electrical system is subject to great stresses during the winter. Lighting and starter motor are used more often. The battery capacity is impaired at low air temperature. The state of charge must be checked more frequently, and if necessary the battery should be charged. The battery may freeze if the state of charge is low.

## Brake system

During cold weather the brakes are subject to splash and condensation which can result in the parking brake freezing up, especially if applied for long periods of time. Use of first or reverse gear on a manual transmission or position "P" on an automatic transmission is preferable during these conditions. See section titled "Brake System".

## Windshield washers

Anti-freeze should also be added to the water container for the windshield and rear window (tailgate, wagon model) washer. This is particularly important during the winter because the windshield frequently becomes dirty and is often splashed with water which rapidly freezes. This may necessitate the frequent use of the windshield washer and wipers. Your Volvo dealer can supply you with suitable anti-freeze for this purpose.

## Anti-freeze for door locks

Lubricate the outside locks with a suitable anti-freeze. Such agents are commercially available and should be used before the first frost.



Volvo Supports Voluntary Mechanic Certification by the N.I.A.S.E.

Certified mechanics have demonstrated a high degree of competence in specific service areas. Besides passing exams, each mechanic must also have worked in the field for two or more years before a certificate is issued. These professional mechanics are fully able to analyze vehicle problems and perform the necessary service procedures to keep your Volvo at peak operating condition.

**NOTE:** The above pertains to U.S.A. only.

The diagnosis outlined below is only intended to serve as a guide to locate and temporarily correct minor faults. Causes for unsatisfactory performance should be investigated and corrected by your Volvo dealer.

**NOTE:** The points indicated by an asterisk (\*) should be checked by your Volvo dealer.

## Condition: Starter fails to operate (or operates very slowly)

Possible cause	Correction
Weak battery or dead cell.	With the ignition switch in the "Driving" or "On" position, check to see if the warning lights on the dashboard come on and if they stay on when the starter is engaged. If the lights do not come on or if they go off when the starter is engaged, the battery is discharged or see below.
Loose or corroded battery cable terminals.	Check battery terminals and clamps. Clean or replace if necessary. Check that the starter cable is secure at its terminals. The ground strap, which connects the body to the rear of the engine, should also be checked for corrosion or looseness.
Open circuit between ignition/starter switch and ignition terminal on starter.	The circuit is closed if a clicking sound is heard from the starter when it is engaged. If no clicking sound is heard, check that the blue wire at the starter is secure. If still no clicking sound is heard, the ignition switch or the wire is defective.
Starter motor defective.	If the above checks have been performed, and no fault is evident, the starter may be defective.
	<b>NOTE:</b> In this case the headlight intensity will not dim when the starter is engaged.



## Service diagnosis

### Condition: Starter motor operates but engine does not start

Possible cause	Correction
Intake system leaking.	Check vacuum hose connections at manifold and auxiliary air valve.
No fuel reaching engine.	Check for fuel in the tank. Check fuses No 5,7 and 13.
No spark.	Remove one spark plug wire and unscrew the radio interference suppressor. Hold the wire approx. 3/8" (10 mm) from the valve cover and run the starter.  If there is no spark, check that the high tension lead from the coil to the distributor cap is connected and that the wires to the distributor and coil are connected.
Spark plugs, high tension leads or distributor cap wet or defective.	Clean the parts with a dry cloth or spray with a moisture remover. Replace defective or worn parts.
Cold start injector defective.	Test the cold start injector function with cold and hot engine.*
Rest pressure incorrect.	Test rest pressure and the fuel system for leaks.*  If no fault is found, following the above steps, contact your Volvo dealer.

\* Should be checked by a Volvo dealer.

## Condition: Erratic idle (misfiring)

Possible cause	Correction
Intake system leaking.	Check vacuum hose connections at manifold and auxiliary air valve.
Sparks plugs, high tension leads or distributor cap worn (defective).	Clean distributor cap and leads, check the cap for cracks. Replace defective or worn parts.
Worn spark plugs.	Remove. Clean or replace spark plugs.
Cold start injector leaking.	Test the injector function.*
Uneven compression.	Test compression.*

## Condition: Engine stalls at irregular intervals

Possible cause	Correction
Defective wires.	Check wire terminals at: fuel pump, fuses No. 5,7 and 13, coil, distributor, ignition switch and relays.
Intake system leaking.	Check vacuum hose connections at manifold and auxiliary air valve.
Low idle, speed.	Adjust.*
Fuel filter clogged.	Clean fuel tank filter and replace line fuel filter.

\* Should be checked by a Volvo dealer.

## Service diagnosis

---

### Condition: Low top speed, loss of power

Possible cause.	Correction
Air filter clogged.	Check air filter.*
Throttle misadjusted.	Check that the throttle touches the high speed stop when the accelerator is fully depressed.*
Incorrect timing.	Check and adjust.*
Fuel filter clogged.	Clean fuel tank filter and replace fuel line filter.*

### Condition: Excessive fuel consumption

Possible cause	Correction
Fuel lines leaking.	Check tightness.
Spark plugs worn.	Replace plugs.
Incorrect timing.	Check/adjust.*
Air filter clogged.	Check/replace.*
Control pressure incorrect.	Check/replace control pressure regulator.*
Cold start injector leaking.	Replace injector.* (A leaking cold start injector also causes uneven idle and hard starting.)

\* Should be checked by a Volvo dealer.



### Condition: Dieseling

Possible cause	Correction
Injector leaking.	Check air flow sensor plate and rest pressure.*

### Condition: Misfiring at highway driving

Possible cause	Correction
Spark plugs fouled.	Drive the vehicle in a lower gear and keep the engine rpm higher for a few miles in order to remove carbon deposit on the spark plugs. If this procedure is not effective, clean or replace the spark plugs.

\* Should be checked by a Volvo dealer.



## Dimensions and weights

	2 door models	4 door models	Wagon models
Length	192.5" (489 cm)	192.5" (489 cm)	192.5" (489 cm)
Width	67.3" (171 cm)	67.3" (171 cm)	67.3" (171 cm)
Height, curb weight	56.3" (143 cm)	56.3" (143 cm)	57.5" (146 cm)
Wheelbase	104.0" (264 cm) <sup>1)</sup>	104.0" (264 cm) <sup>1)</sup>	104.3" (265 cm)
Ground clearance (full load)	4.7" (12 cm)	4.7" (12 cm)	4.7" (12 cm)
Track, front	56.3" (143 cm)	56.3" (143 cm)	56.3" (143 cm)
rear	53.5" (136 cm)	53.5" (136 cm)	53.5" (136 cm)
Turning circle (between curbs)	32.2' (9.8 m)	32.2' (9.8 m)	32.2' (9.8 m)
Curb weight (depending on type)	2891–2999 lbs (1312–1362 kg)	2933–3065 lbs (1332–1392 kg)	3129–3162 lbs (1421–1436 kg)
Gross vehicle weight (GVW)	4030 lbs (1830 kg)	4030 lbs (1830 kg)	4300 lbs (1950 kg)
Capacity weight	920 lbs (420 kg)	920 lbs (420 kg)	1120 lbs (520 kg)
Permissible axle weight, front	1885 lbs (855 kg)	1885 lbs (855 kg)	1885 lbs (855 kg)
rear	2180 lbs (990 kg)	2180 lbs (990 kg)	2600 lbs (1180 kg)
Max. trailer weight	2000 lbs (908 kg)	2000 lbs (908 kg)	2000 lbs (908 kg)
Max. hitch load	200 lbs (90 kg)	200 lbs (90 kg)	200 lbs (90 kg)

<sup>1)</sup> 104.3" (265 cm) for cars with power steering

## Cargo Space

	Wagon models
Length with rear seat up	44.5" (113 cm)
Length with rear seat down	74.0" (188 cm)
Maximum width	53.1" (135 cm)
Height	32.9" (84 cm)
Volume with rear seat up	41 cu. ft. (1.2 m <sup>3</sup> )
Volume with rear seat down	71 cu. ft. (2.0 m <sup>3</sup> )
Cargo opening, maximum width	45.7" (116 cm)
Cargo opening, maximum height	30.7" (78 cm)

## Capacities

Fuel tank	15.8 US gals. = 60 liters/13.2 Imp. gals.
Cooling system	9.9 US qts. = 9.4 liters/8.9 Imp. qts. (of which expansion tank 1 US qt./0.5 Imp.qt. (0.6 liter)
Oil capacity,	
engine, at oil change	3.5 US qts. = 3.35 liters/3.0 Imp. qts.
incl. oil filter	4.0 US qts. = 3.85 liters/3.4 Imp. qts.
transmission (M 45)	0.8 US qt. = 0.75 liter/0.7 Imp. qts.
(M 46)	2.4 US qts. = 2.3 liters/2.2 Imp. qts.
autom.	7.3 US qts. = 6.75 liters/6.4 Imp. qts.
rear axle	1.7 US qts. = 1.6 liters/1.4 Imp. qts.
steering gear, power	0.8 US qt. = 0.75 liter/0.7 Imp. qts.



# Specifications

## ENGINE

4-cylinder in-line liquid-cooled gasoline engine. Cylinder block in special cast iron. Cylinders are bored directly in block. Cylinder head in light-alloy. Separate inlet and exhaust passages. Single, overhead camshaft.

Engine lubrication is provided by a gear pump driven from crankshaft. Full-flow type oil filter. Exhaust emission control accomplished by fuel injection. Exhaust Gas Recirculation (some models also equipped with Lambda-sond™ system and 3-way catalytic converter. Closed crankcase ventilation system and evaporative emission control system.

### Type designation

Output (SAE J 245) at/rpm  
Max torque (SAE J 245) at/rpm  
Number of cylinders  
Bore  
Stroke  
Displacement  
Compression ratio  
Valves  
Valve clearance, inlet and exhaust engine at normal operating temp.

### B21 F

107 hp/5250\*  
114 ft. lbs. = 154 Nm/2500\*\*  
4  
3.62" (92 mm)  
3.15" (80 mm)  
2.13 liters  
9.3  
overhead  
0.012–0.020" (0.30–0.50 mm) when checking  
0.016–0.018" (0.40–0.45 mm) when adjusting

### B21 A (Canada)

96 hp/5250  
121 ft. lbs. = 163 Nm/2500  
4  
3.62" (92 mm)  
3.15" (80 mm)  
2.13 liters  
8.5  
overhead

\* ) Canada version: 111 hp/5250 rpm

\*\* ) Canada version: 120 ft. lbs. = 162 Nm/4500 rpm.

Cars with catalytic converter: 114 ft. lbs. = 154 Nm/2500 rpm.

### Cooling System

Type  
Thermostat – begins to open at fully open at  
Fan belts, designation

Positive pressure, closed system  
189° F (87° C)  
207° F (97° C)  
HC – 38×925

### Fuel System

Fuel injection  
CI-system

Carburetor  
Stromberg

# Specifications

## Ignition System

Firing order	1-3-4-2
Ignition setting, vacuum regulator disconnected, at 750 ±50 rpm:	
Engine B 21 A	12° ±2° BTDC
Engine B 21 F Canada	10° ±2° BTDC
Engine B 21 F, USA	8° ±2° BTDC
Spark plugs, engine B 21 A	Volvo Part No. 273592-6 or Bosch W 7 DC*
Spark plugs, engine B 21 F	Volvo Part No. 273594-2 or Bosch WR 7 DS*
Spark plug gap	0.7–0.8 mm (0.028–0.032")
Tightening torque	20–30 Nm (14.5–21.7 ft. lbs.)
Distributor, direction of rotation	Clockwise

## ELECTRICAL SYSTEM

12 V, negative ground.  
Voltage-controlled alternator.  
Single-wire system with chassis and engine used as conductors.

Voltage	12 V
Battery	Volvo Part No. 1235266*
Capacity	70 Ah
Electrolyte, specific gravity	1.28
Recharge at	1.21
Alternator, rated, output	770 W
max. current	55 A

\* or corresponding

Lights, 12 V	US bulb No.	Power	Socket	No. of bulbs
Headlights, 2 door		7" Type 2 Sealed Beam		2
Headlights, inner	4 and 5 door round	5 <sup>3</sup> / <sub>4</sub> " Type 1 Sealed Beam		2
Headlights, outer				
Headlights, inner	4 and 5 door square	5 <sup>3</sup> / <sub>4</sub> " Type 2 Sealed Beam		2
Headlights, outer				
Headlights, front	67	4×6 <sup>1</sup> / <sub>2</sub> " Type 2A Sealed Beam	Ba 15 s	2
Turn Signals, front	1073	5 W/4 cp	Ba 15 s	2
Turn Signals, rear	1073	21 W/32 op	Ba 15 s	2
Tail Lights	67	21 W/32 cp	Ba 15 s	4
Stop Lights	1073	5 W/4 cp	Ba 15 s	2
Back-up Lights	1073	21 W/32 cp	Ba 15 s	2
Side Marker Lights	57	4 W/2 cp	Ba 9 s	2

The following bulbs may be obtained from your nearest Volvo dealer:

Rear Ash Tray Light	1.2 W	W 1.8 d	1
License Plate Light, 2, 4 door	4 W	Ba 9 s	2
License Plate Light, Wagon	5 W	S 8.5	2
Interior Light	10 W	S 8.5	1
Glove Box Light	2 W	Ba 9 s	1
Instrument Panel Light	2 W	Ba 7 s	3
Control Panel Light	1.2 W	W 1.8 d	3
Shift Positions,			
Auto Transmission	1.2 W	W 1.8 d	1
Trunk light	15 W	S 8.5	1
Warning Lamps			
Charging	1.2 W	W 1.8 d	1
Turn Signals	1.2 W	W 1.8 d	2
Brake Failure	1.2 W	W 1.8 d	1
Parking Brake	1.2 W	W 1.8 d	1
Headlights	1.2 W	W 1.8 d	1
Oil Pressure	1.2 W	W 1.8 d	1
Overdrive	1.2 W	W 1.8 d	1
Warning Flashers	1.2 W	W 1.8 d	1
El. Heated Window	1.2 W	W 1.8 d	1
Lambda Sond™ Reminder	1.2 W	W 1.8 d	1
Seat Belts	2 W	Ba 9 s	2
Bulb Failure	1.2 W	W 1.8 d	1

# Specifications

## FRONT END

Suspension is of the McPherson type with the shock absorber mounted in a strut in the coil spring.

Rack and pinion steering gear.

Power steering is standard on most models.

Safety steering column.

## Front wheel alignment

The alignment specifications apply to an unloaded car but include fuel, coolant and spare wheel.

Toe-in 3/16" =  $0.11 \pm 0.04$ " (2.5  $\pm$  1 mm) manual steering

(On rim) 1/8" =  $0.06 \pm 0.04$ " (1.5  $\pm$  1 mm) power steering

Camber 0° to +1° (Difference not to exceed 1/2° between left and right side.)

Caster not adjustable

## POWER TRANSMISSION

Cable-operated clutch of the single, dry-plate type.

Floor-shift operated manual transmission has four synchromesh forward gears and one reverse.

Overdrive available on some models.

Optional automatic transmission.

Hypoid type final drive. Limited slip differential is optional.

## Clutch

Clutch release arm play approx. 1/8" (3 mm)

## Transmission

Type designation	M 45	M 46	AW 55 BW 55
Reduction ratios			
1st gear	3.71:1	3.71:1	2.45:1
2nd gear	2.16:1	2.16:1	1.45:1
3rd gear	1.37:1	1.37:1	1.00:1
4th gear	1.00:1	1.00:1	—
Overdrive	—	0.80:1	—
Reverse	3.68:1	3.68:1	2.21:1

## Rear axle

Reduction ratio	3.91:1	3.91:1	3.73:1
-----------------	--------	--------	--------

## Speeds in mph (km/h) at 1000 engine rpm

Transmission	M 45	M 46
Rear axle ratio	3.91:1	3.91:1
1st gear	5.0 (8.1)	5.0 (8.1)
2nd gear	8.6 (13.9)	8.6 (13.9)
3rd gear	13.6 (21.9)	13.6 (21.9)
4th gear	18.7 (30.0)	18.7 (30.0)
Overdrive	—	23.3 (37.5)
Reverse	5.1 (8.2)	5.1 (8.2)



## Recommended max. and min. speeds, mph (km/h)

Rear axle ratio:	1st gear	2nd gear	3rd gear	4th gear
3.91:1	-25 (-40)	10-44 (20-70)	20-70 (30-110)	25*-(44*)

\* 40 mph (\*65 km/h) with overdrive engaged

## TIRES

### Tire pressures

Car model	Vehicle capacity weight, lbs (kgs)	Tire	Recommended inflation pressure psi (kPa)							
			Normal speed				>75 mph (120 km/h)			
			1-3 persons		Full load					
			Front	Rear	Front	Rear	Front	Rear		
2/4 door models	DL	920(420)	175 R 14	26(180)	27(190)	26(180)	32(230)	30(210)	36(250)	
		920(420)	DR 78-14	26(180)	28(200)	26(180)	32(230)	26(180)	32(230)	
	GL	920(420)	185/70 R 14	26(180)	27(190)	28(200)	32(230)	28(200)	32(230)	
	GT	920(420)	195/60 R 15	26(180)	27(190)	28(200)	32(230)	28(200)	32(230)	
		"Special Spare"			32(230)	32(230)	32(230)	32(230)	**	**
Wagon models	DL	1120(520)	DR 78-14	26(180)	30(210)	26(180)	32(230)	*	*	
	DL, GL	1120(520)	185 R 14	27(190)	30(210)	28(200)	36(250)	28(200)	36(250)	
			"Special Spare"	40(280)	40(280)	40(280)	40(280)	**	**	

\* Max 75 mph (120 km/h)

\*\* Max 50 mph (80 km/h)

## Tool kit

Wheel nut and spark plug wrench  
 2 screwdrivers (1 Philips, 1 standard)  
 Tommy bar  
 2 open end wrenches

## Volvo service manuals

---

Service Manuals for your Volvo are available for purchase. These are the same used by competent Volvo technicians. Each major system in the car is covered by an individual Manual. These are grouped into ten sections and placed into a five-binder system. (Note that Manuals and binders may be obtained separately or in preassembled sets.)

Major sections within the five-binder system include: 0-General Information; 1-Service and Maintenance Instruction; 2-Engine; 3-Electrical System; 4-Power Transmission; 5-Brakes; 6-Front End and Steering; 7-Frame Suspension and Wheels; 8-Body, 9-Accessories and Other Equipment.

A Service Manual Brochure and Order Form was placed in the car prior to delivery from the dealer to you. Complete ordering information is provided.

Please note that these manuals may be offered for sale by your Volvo dealer.

Prices charged by the dealer can vary from those listed in the brochure (according to federal law).

Additional copies of the Brochure and Order Form may be obtained from your Volvo dealer, or by mail directly from:

Volvo of America Corporation  
Rockleigh Industrial Park  
Rockleigh, New Jersey 07647

Attention: Volvo Service Literature

**Note that the above pertains to vehicles sold in the U.S.A. only.**

Air Conditioning .....	18	Diagnosis .....	83	Gas station checks .....	44
Alternator, important note .....	62	Dimensions and weights .....	89	Gear shift positions .....	35
Anti-freeze .....	61	Dipstick .....	49	Hand brake .....	13
Anti-rust treatment .....	77	Door lock anti-freeze .....	81	Hazard warning flasher .....	12
Ash trays .....	14	Doors and locks .....	24	Headlight flasher .....	8
Automatic transmission, driving .....	36	Drain plug, engine .....	49	Headlights .....	9, 63
oil .....	58	rear axle .....	59	replacement .....	63—65
Battery .....	44, 91	manual transmission .....	57	Heating .....	16
Body and chassis .....	60	automatic transmission .....	58	Hood lock .....	26
Brake fluid .....	44, 59	Drive belts .....	50	Horn .....	4
Brakes .....	41	Driving with trunk lid open .....	40	Ignition and steering wheel lock .....	8
Break in period .....	32	Electrical system .....	91	Instrument lights .....	9
Bulb failure warning light .....	7	Emergency towing (pulling) .....	38	Instruments and controls .....	4
Bulbs .....	63, 91	Engine .....	45, 90	Interior light .....	28, 69
Capacities .....	89	Engine oil .....	44, 49	Jack .....	74
Carburetor .....	54	Far. belts .....	50	Keys .....	3
Cargo space .....	89	Fault tracing .....	83	Kick-down .....	37
Chassis number .....	88	Federal Clean Air Act .....	43	License plate lights .....	68
Checking coolant .....	44, 61	Fresh-air controls .....	17	Lighting .....	9
oil .....	49	Front seats .....	20	Limited slip differential .....	59
Child safety locks .....	25, 30	Front wheel alignment .....	92	Locks .....	24
Cigarette lighter .....	14	Frozen locks .....	24	Long distance trips .....	80
Clock .....	14	Fuel .....	28, 44	Lubrication .....	60
Cold start .....	34	Fuel gauge .....	6	Lumbar support .....	20
Cold weather driving .....	81	Fuel tank cap .....	28	Maintenance Service .....	43
Control lights .....	6	Fuses .....	70		
Coolant .....	61	Gas filler cap .....	28		
Coolant, drain .....	50	Gasoline .....	28, 44		
Cooling system .....	50, 61, 81, 90				
Defroster .....	16				



# Index

Odometer .....	6	Shift positions .....	35	Trunk, 2 and 4 door models .....	25
Oil change, engine .....	49	Shop manuals, Volvo .....	94	Turn signals .....	8
rear axle .....	59	Snow chains .....	72	Type designations .....	88
transmission .....	57, 58	Snow tires .....	72	Upholstery, cleaning .....	77
Oil filter .....	49	Spare wheel .....	25, 31, 73	Vehicle Identification Number .....	88
Oil pressure .....	7	Spark plugs .....	55, 91	Ventilation louvers .....	16
Overdrive .....	35	Specifications .....	88	VIN, VIC .....	88
Paint touch-up .....	78	Speedometer .....	6	Warning lights .....	7
Parking brake .....	13	Starting engine .....	34	Warranty .....	43
Parking lights .....	9	Starting key .....	3	Warranty inspection .....	32
Polishing .....	77	Steering wheel lock .....	8	Washer fluid .....	44, 81
Power steering .....	59	Storage space, Wagon models .....	31	Washer nozzles .....	10
Power train .....	58, 92	Sun roof .....	28	Washing .....	77
Radios .....	19	Tachometer .....	6	Waxing .....	77
Rear axle oil .....	59	Tailgate .....	30	Weights .....	89
Rear, seat, Wagon models .....	29	Tailgate window washer/wiper .....	10	Wheel alignment .....	92
Rear view mirrors .....	27	Temperature gauge .....	6	Wheel change .....	74
Rear window demister .....	12	Tire pressure .....	71, 93	Wheels and tires .....	71
Rust protection .....	77	Tires .....	71	Windshield washers .....	10, 44, 45, 81
Seat belts .....	22	Tire wear indicator .....	71, 72	Windshield wipers .....	10
Seats .....	20	Tools .....	93	Wintertime driving .....	81
Service Diagnosis .....	83	Touch-up .....	78		
Servicing .....	46	Towing .....	38		
		Trailer hauling .....	40		
		Transmission oil .....	57, 58		

## When gas tank is being filled always check:

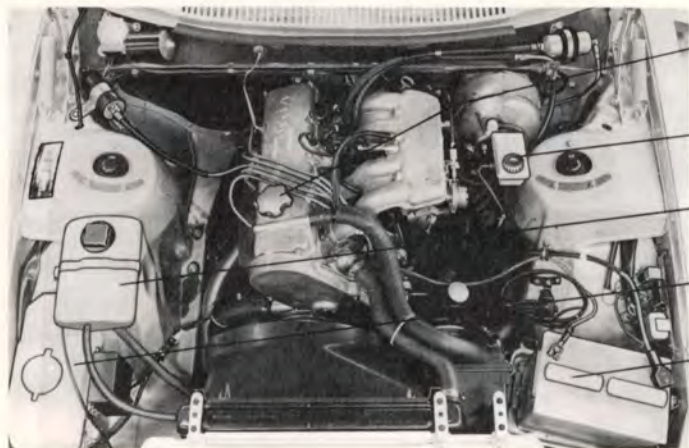

Oil level between dipstick marks. The distance between the marks represents 1 US qt = 1 liter/1 Imp. qt. Fill multigrade oil.

Check without removing the cap that the **brake fluid** level is above the MIN-mark. Brake fluid DOT 4.

**Coolant level** between the expansion tank marks. Mixture 50 % anti-freeze and 50 % water.

**Washer fluid reservoir** should be filled with water and solvent (wintertime: windshield washer anti-freeze).

**Electrolyte level** 1/4"-3/8" (5-10 mm) above plates. Fill distilled water only, never acid. Check level in conjunction with normal service or once a year.

For vehicles with catalytic converter unleaded fuel must be used.

Octane rating **91 RON (injection engine)**  
**93 RON (carburetor engine)**

Car model		Vehicle capacity weight. lbs (kgs)	Tire	Recommended cold tire inflation pressure psi (kPa)					
				Normal speed		>75 mph (120 km/h)			
				1-3 persons		Full load			
			Front	Rear	Front	Rear	Front	Rear	
2/4 door models	DL	920 (420)	175 R 14	26 (180)	27 (190)	26 (180)	32 (230)	30 (210)	36 (250)
		920 (420)	DR 7814	26 (180)	28 (200)	26 (180)	32 (230)	26 (180)	32 (230)
	GL	920 (420)	185/70 R 14	26 (180)	27 (190)	28 (200)	32 (230)	28 (200)	32 (230)
	GT	920 (420)	195/60 R 15	26 (180)	27 (190)	28 (200)	32 (230)	28 (200)	32 (230)
			"Special Spare"	32 (230)	32 (230)	32 (230)	32 (230)	**	**
Wagon models	DL	1120 (520)	DR 78-14	26 (180)	30 (210)	26 (180)	32 (230)	*	*
	DL, GL	1120 (520)	185 R 14	27 (190)	30 (210)	28 (200)	36 (250)	28 (200)	36 (250)
				"Special Spare"	40 (280)	40 (280)	40 (280)	40 (280)	**

\* Max 75 mph (120 km/h)

\*\* Max 50 mph (80 km/h)

PLUC  
SET 035  
CHANGED 52020

---

# **VOLVO**

**AB VOLVO • GÖTEBORG, SWEDEN**

---