

VOLVO

Coupe



OWNER'S MANUAL 1981 USA/CANADA

Notice to Owner: Your Volvo has been built to comply with all U.S.A. and Canada safety and anti-pollution regulations. Evidence of this can be verified from the certification labels attached to the door opening sheet metal and on the left wheel housing in the engine compartment. For further information regarding these regulations, please contact your local dealer.

Owner Information

Name

Address

City, State

Tel. No.

Car Information

Vehicle Identification
Number (VIN)

Ignition/Door Key No.

Trunk/Glove Box Key No.

Delivery Date

Notice: All information, illustrations and specifications contained in this manual are based on the latest product information available at the time of publication. Volvo reserves the right to make model changes at any time, or to change specifications or design, without notice and without incurring obligation.

DESCRIPTION	Page		
General Information	2	Emergency towing	34
Keys	3	Towing information	35
Instruments and controls	4	Trailer hauling	36
Instruments	6	Automatic transmission, brake system	37
Warning lights	7	Catalytic converter	38
Ignition switch, parking brake	8	MAINTENANCE SERVICE	
Lighting	9	Maintenance services	39
Turn signals	10	Gas station checks	40
Cruise control	11	Engine B28F	41
Windshield wipers	12	Servicing	42
Electrically operated windows	13	Engine oil	44
Rear window demister, hazard warning flasher, electrically heated passenger seat	14	Cooling system	46
Rear side view mirrors	15	Servicing	47
Heating and ventilation, air conditioning	16	Transmission oil	54
Clock, cigarette lighter, ash tray	18	Rear axle, power steering, brake fluid	56
Interior light	19	Lubrication	57
Radios, AM-FM-FM Stereo-CB/tape players, elect. operated antenna	20	Coolant	58
Front seats	21	Alternater, jump starting	59
Seat belts	22	Replacing bulbs	60
Doors and locks	24	Fuses	64
Trunk lid	25	Wheels and tires	65
Hood, fuel tank cap	26	Wheel changing	68
STARTING AND DRIVING		Washing, cleaning	70
Service inspection	27	Anti-rust treatment	70
Break in period	28	What causes rust	71
Driving for economy	29	Paint touch-up	72
Starting the engine	30	Long distance trips, Cold weather	74
Gear shift positions	31	Service diagnosis	75
Automatic transmission	32	Specifications	80
		Volvo service manuals	86
		INDEX	87

General Information



Do not export your Volvo to another country before investigating that country's applicable safety and exhaust emission requirements. In some cases it may be impossible to comply with these requirements.



**Ignition/Steering wheel lock
Front doors**



**Trunk
Glove box**

Write the key number codes on the inside of the front cover of this manual. (See tag attached to plastic key ring). In the event the original keys are lost, duplicates may be ordered from your Volvo dealer.



Tag

Instruments and Controls

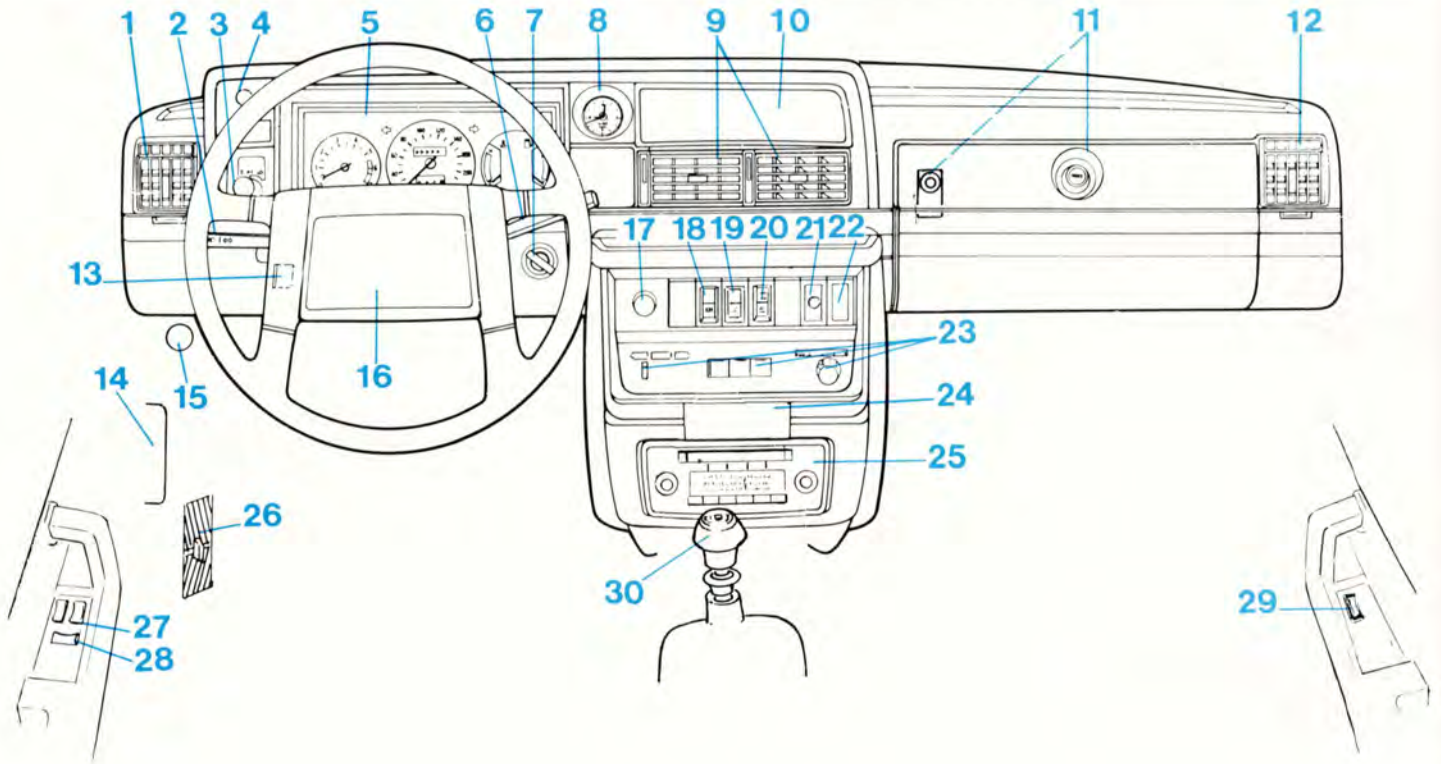

Instruments and Controls

	See page
1 Fresh air louver	17
2 Turn signals	10
Cruise control	11
3 Headlights, parking lights	9
4 Instrument lights	9
5 Instruments	6
6 Wiper/washer	12
7 Ignition switch/steering wheel lock	8
8 Clock	18
9 Fresh air louvers	17
10 Storage compartment (extra instrument location)	-
11 Glove box	-
(elec. button for trunk lock)	25
12 Fresh air louver	17
13 Interior light	19
14 Fuse box	64
15 Hood release handle	26
16 Horn	-
17 Cigarette lighter	18
18 Rear window demister	14
19 Electrically heated passenger seat	14
20 Hazard warning flasher	14
21 Air conditioning	16
22 Seat belt reminder light	22
23 Heating and ventilation	16
24 Ash tray	18
25 Radio	20
26 Fresh air intake	17

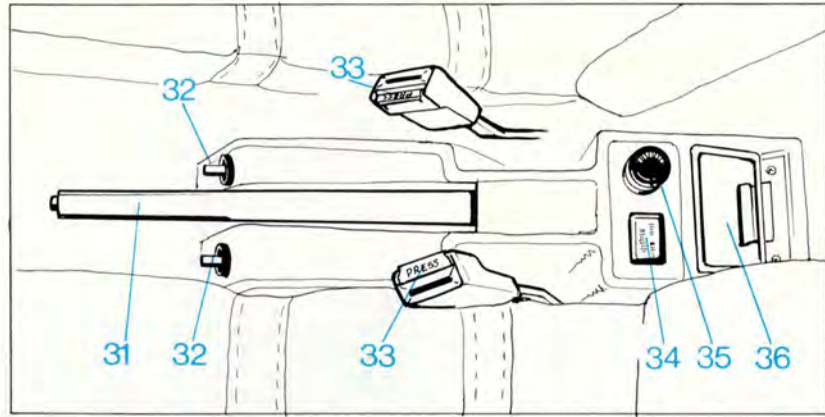

	See page		See page
27 Switches, window winder	13	32 Control for electrically operated side mirrors	15
28 Switch, central lock	24	33 Seat belt release buttons	22
29 Switch, window winder	13	34 Seat belt reminder light	22
30 Gear lever or gear selector	31, 32	35 Cigarette lighter	18
31 Parking brake	8	36 Ash tray	18

The pages in this section provide a detailed description of the vehicle's instruments and controls.

Note that vehicles may be differently equipped, depending on special legal requirements, etc.

Instruments

A Tachometer

Reads thousands of engine rpm.
Black range for momentary use, during acceleration.
Engine should not be operated in red range.

B Left turn signal indicator (green)

C Speedometer

In kilometers and miles.

D Odometer

Total mileage reading

E Trip odometer

(last figure represents 1/10 mile/km)

F Right turn signal indicator (green)

G Temperature gauge

The gauge pointer should remain inside the black range during normal operation. If the pointer enters the red range repeatedly,

check coolant level and fan belt tension. (See sections titled "Cooling system and coolant".)

WARNING! Allow engine to cool before adding fluid.

H Fuel gauge

The fuel tank capacity is approx 60 liters= 15.8 US gals.
The red range represents approx. 2.1 US gals.=8 liters.



I Reminder light, Lambda-sond™* (oxygen sensor system) service

J Alternator warning light (red)

K Oil pressure warning light (red)

L Overdrive indicator light (green)

Lights when overdrive is engaged.

M Trip odometer reset knob

Push in to reset

N High beam indicator (blue)

O Parking brake reminder light (red)

P Brake failure warning light (red)

R Bulb failure warning light (yellow)

* Lambda-sond™ is a trademark of Volvo of America Corporation.

The warning lights described on this page should never be on when driving

When the ignition key is turned on, and before the engine starts, all of the warning lights should be on to test the function of the bulbs. Should a light not go off after the engine has started, the system indicated should

be inspected. (However, the parking brake reminder light will not go off until the parking brake is fully released.)

I Lambda-sond™ (oxygen sensor system) service reminder light (red)



As required by the U.S. Environmental Protection Agency this light will come on at 30,000 mile (50,000 km) intervals. It is a reminder to have the oxygen sensor system serviced. The light will stay on until reset by servicing dealer.

K Oil pressure warning light (red)



If the light comes on during driving, the oil pressure is too low. Stop the engine immediately and check the engine oil level. See section titled "Engine Oil". After hard driving, the light will come on occasionally when the engine is idling. This is normal, provided it goes off when the engine speed is increased.

P Brake failure warning light (red)



If the light comes on while driving and the brake pedal can be depressed further than normal, it is an indication that one of the brake circuits is not functioning. Proceed cautiously to a Volvo dealer for an inspection of the brake system.

J Alternator warning light (red)



If the light comes on while the engine is running, check the tension of the alternator drive belt as soon as possible. (See section titled "Cooling system".)

NOTE:

This warning light is illuminated if the alternator is not charging. However, **oil pressure, alternator, parking brake, brake failure, Lambda-sond™ system service reminder and bulb failure will be illuminated at the same time** due to the design of the system.

O Parking brake reminder light (red)



This light will be on when the parking brake (hand brake) is applied. The parking brake lever is situated between the front seats.

R Bulb failure warning light (yellow)



The light will come on if any of the following bulbs are defective:

- one of the lower beams
- one of the tail lights
- one of the brake lights (when the brake pedal is depressed).

See section on "Replacing Bulbs".

Ignition switch, parking brake

Ignition switch/steering wheel lock



- 0 Locked position:**
remove the key to lock the steering wheel.



- I Intermediate position:**
certain circuits (heater blower, cigarette lighter, accessories, etc.) on.



- II Driving position:**
key position when engine is running.



- III Starting position:**
release the key when engine starts. The key returns automatically to driving position.

The steering wheel lock might be under tension when the car is parked. Turn the steering wheel slightly to free the ignition key.



Parking brake (hand brake)

The lever is situated between the front seats. The brake is applied to the rear wheels. Always use the parking brake (hand brake) when parking, to maintain the best possible function.

For winter use, see section titled "Cold weather".

A buzzer will sound if the ignition key is in the ignition lock and the front door on the driver's side is open. The buzzer will also sound if the headlights or parking lights are on when the door is open.

The buzzer goes off when the front door is closed.



Parking brake reminder light

The reminder light PARKING BRAKE on the instrument panel comes on whenever the parking brake lever is not fully released and the ignition is on.

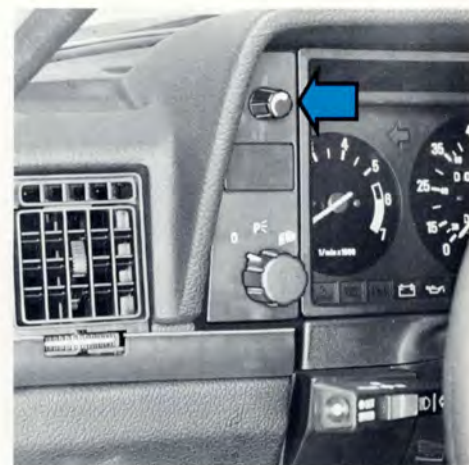

Headlights and position lights

- 0** All lights off
- P** Parking lights on
- D** Headlights and parking lights on

Switch from upper to lower beams, and vice versa, by moving the turn signal switch lever on the left side of the steering column towards the steering wheel. The lights can be used without switching on the ignition key.

A buzzer will sound if the headlights or parking lights are on and the front door on the driver's side is open. The buzzer will also sound if the ignition key is in the ignition lock when the door is open.

The buzzer goes off when the front door is closed.

Instrument panel lamps rheostat

Clockwise – brighter
Counterclockwise – dimmer.

Turn signals

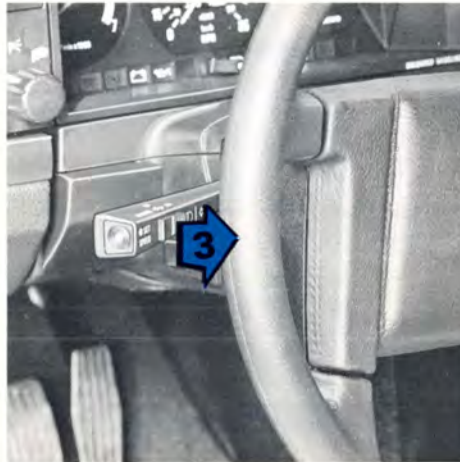
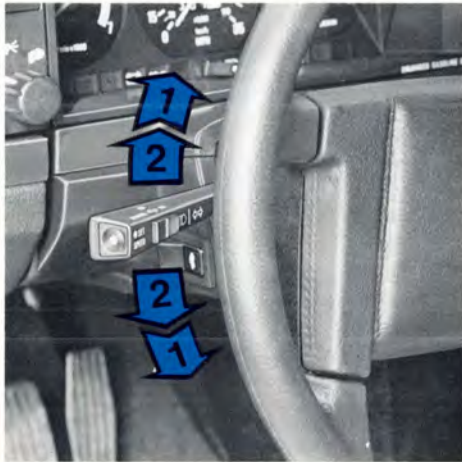

Turn signals

1 Signal lever engaged for normal turns.

Defective turn signal bulb will cause turn signal indicator and remaining signal lights to flash more rapidly.

2 Lane change position. In maneuvers such as lane changing, the driver can flash the turn signals by moving the turn signal lever to the first stop and holding it there. The lever will return to the neutral position when released.

3 High and low beam switching (headlights on).

Move the lever towards the steering wheel and release it.

3 Headlight flasher (headlights off).

Move the lever towards the steering wheel. The headlight high beam will be on until the lever is released.

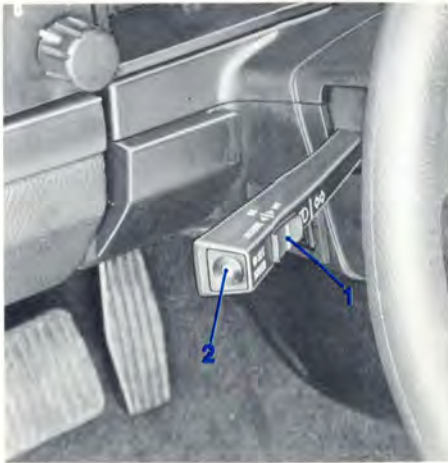

Cruise control

The cruise control switches are located on the turn signal switch lever.

To engage and set desired speed:

1. Set switch (1) to ON.
2. Accelerate to desired cruise speed.

NOTE:

The cruise control cannot be engaged at speeds below 30 mph.

3. Depress switch SET SPEED (2).

When lower cruise speed is desired

Depress switch SET SPEED and hold it in until desired speed has been reached.

Operating clutch pedal or brake pedal

Will automatically disengage the cruise control. Previously selected cruise speed is retained in the memory. It can be re-introduced by momentarily setting the switch to RESUME position.

NOTE:

The vehicle will accelerate very quickly should there be a substantial speed differential as the switch is reset to RESUME. It is therefore recommended that the vehicle be accelerated manually and the switch reset to RESUME when the speed differential is reduced.

WARNING!

The cruise control should not be used in heavy traffic or when driving on wet or slippery roads.

In case the gear shift unintentionally is moved to Neutral during driving with the cruise control engaged:

- depress the brake pedal (or clutch pedal) momentarily, or set the cruise control switch (1) to OFF.

This will disengage the cruise control and prevent excessive speeds.

Acceleration

Momentary acceleration, such as for passing, does not interrupt cruise control operation. The previously selected speed will be maintained without having to set switch to RESUME.

Disengaging the cruise control system

- Set switch (1) to position OFF.
 - Depress brake pedal or clutch pedal.
 - Depress SET SPEED and hold it depressed.
- Switching off the ignition will automatically disengage the cruise control system.

Windshield wipers

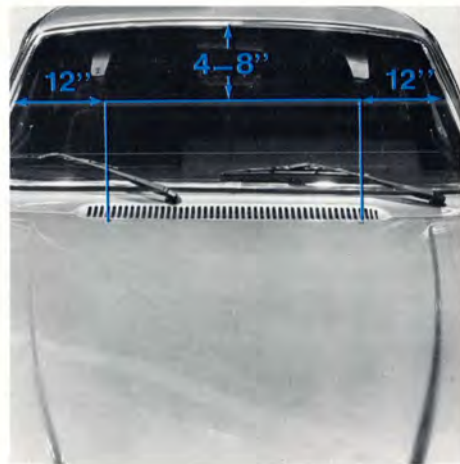

Wiper/washer

1 Intermittent wiper.

With switch in this position, the wipers will make a stroke every seventh second.

2 "Single stroke" position.

Switch returns automatically when released.

3 Wipers, low speed.

4 Wipers, high speed.

5 Wiper and washer.

Adjusting washer nozzles

The nozzles may be adjusted by inserting a needle into the metal nozzle and rotating to desired position.

4-8"=10-20 cm

12"=30 cm

Washer fluid reservoir

The washer fluid reservoir for the windshield washer is located in the engine compartment and holds approx. 1.6 US gals=5.6 liters.

During wintertime, the reservoir should be filled with anti-freeze specified in section titled "Cold weather".

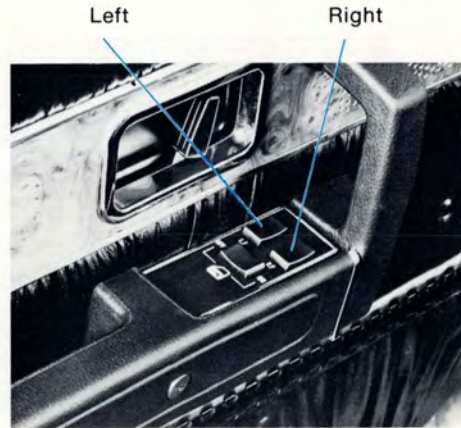

Electrically operated windows

Both doors are equipped with electrically operated windows.

Operation is controlled by switches in the door arm rests. The illustration shows the arm rest of the driver's door, and the relative location of the switches.

The ignition must be ON to enable operation of the windows.

Depressing the rear portion of the switch causes the window to move downward.

Depress forward portion to raise the window.

Rear window demist, elect. heated passenger seat, hazard warning flasher

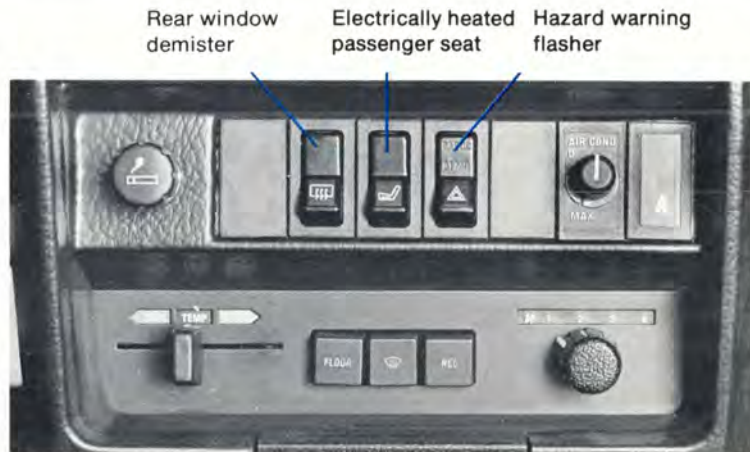
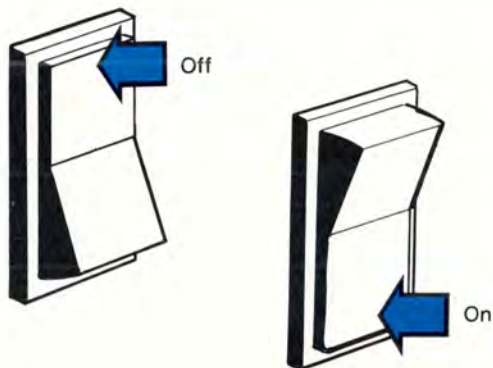

Rear window demister

Switch off the rear window demister when the glass is clear of mist or frost. Otherwise the battery will be unduly strained. Do not place items against the inner surface of the rear window that may damage the printed circuit. Do not scrape the inner surface of the rear window glass with a hard object or use an abrasive window cleaner, otherwise damage to the printed circuit will occur.

Electrically heated passenger seat

The front seats are electrically heated. The heaters are controlled by thermostats. They switch on at temperatures below approx. $+15^{\circ}\text{C}$ ($=60^{\circ}\text{F}$) and off at $+25^{\circ}\text{C}$ ($=77^{\circ}\text{F}$). Switch off the passenger seat heater when the seat is not occupied. The driver's seat heater cannot be deactivated.

Hazard warning flasher

Four way flashing is used to indicate that the vehicle has become a traffic hazard (either during daylight or at night). **NOTE:** Regulations regarding the use of the hazard warning flasher may vary from state to state.

Rear/side view mirrors

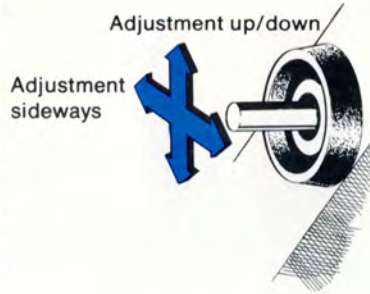
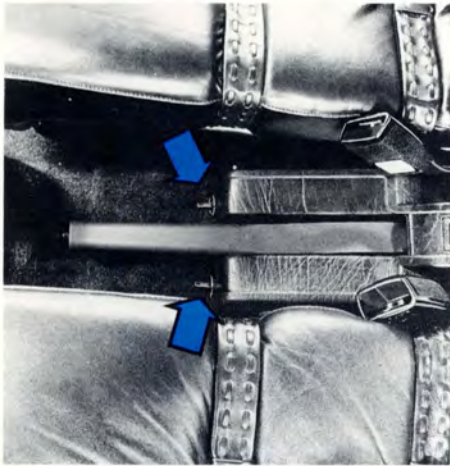

Electrically operated side view mirrors

The control switches are located in front of the parking brake housing.

Avoid using ice scrapers made of metal as they can easily scratch the mirror surface.



Rear view mirror

- D Normal position
- N Night position, reduces glare from following headlights

The mirrors should always be adjusted before driving.

Heating and ventilation, air conditioning

Heater and air conditioner

Heater and air conditioner are built into one unit. With this system it is possible to keep the inside temperature constant regardless of outside temperature. Correct setting of the system controls allows heated or refrigerated air to enter.

1 TEMP

Left = cool

Right = warm

When using the air conditioner the temperature control should be set to COOL, all the way to the left.

Use the compressor control knob to set temperature desired.

2 FLOOR

Out = no air to floor

In = full flow of air to front and rear floor

3 DEF (defrost)

Out = low volume air flow to defroster

In = full flow

4 REC (Recirculation)

Push in for rapid cooling and during high humidity conditions.

Do not use for heating.

Out = full flow of outside air

In = air is recirculated for faster cooling

5 FAN (Blower motor)

1 = low speed

2 = medium speed

3 = high speed

4 = highest speed

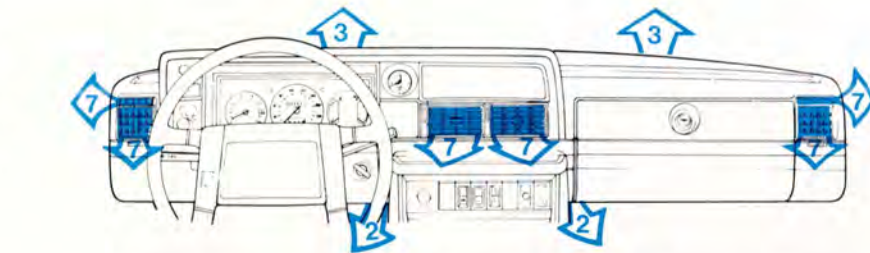

The fan is always in operation, when the ignition switch is in ON-Position.

6 AIR COND

Start the air conditioning compressor by turning the control knob clockwise toward MAX.

For rapid cooling, position the knob into the yellow range beyond MAX. After desired temperature is reached re-position the control knob into the blue range.

At cruising speeds, the knob should be kept within the blue range. If it remains in the yellow range, icing may occur resulting in decreased cooling capacity.

7 Fresh air louvers (dash)

The air flow through the fresh air louvers is decreased when the FLOOR (2) and/or DEF (3) controls are depressed.

How to ...

... obtain max. heat

- 1 TEMP → WARM
- 2 FLOOR depressed
- 5 FAN → 3 (or 4)
- 6 All dash louvers halfway open and floor air louver closed.



... remove condensation

- 1 TEMP → WARM
- 3 DEF depressed
- 5 FAN → 3 (or 4)
- 7 All louvers closed as well as the floor fresh air louver.



Always keep front external inlet grille (in front of the windshield) clear of obstructions (snow, ice, etc.).

Fresh air louvers (dash)

- A Closed
- B Open
- C Directing air flow horizontally
- D Directing air flow vertically

NOTE: For rapid removal of condensation from inside glass surfaces, the air conditioner can be switched on even when not required for interior cooling. The air conditioner will dehumidify the air inside the vehicle.

Have your Volvo dealer check the system for correct operation yearly. The air conditioning system should be operated periodically during the winter season.



Fresh air louver (floor)

There is a floor directed fresh air louver on the driver side of the vehicle.

Airflow is controlled by the lever at the center of the louver.

Lever placed forward – louver opens

Lever placed rearward – louver closes

Maximum airflow is obtained with louver fully open and the fan (blower motor) at lowest setting.

... obtain rapid cooling

- 1 TEMP ← COOL
- 4 REC depressed
- 5 FAN → 4
- 6 AIR COND to MAX
- 7 Ventilation outlets open

All windows must be closed.

Clock, cigarette lighters, ash trays

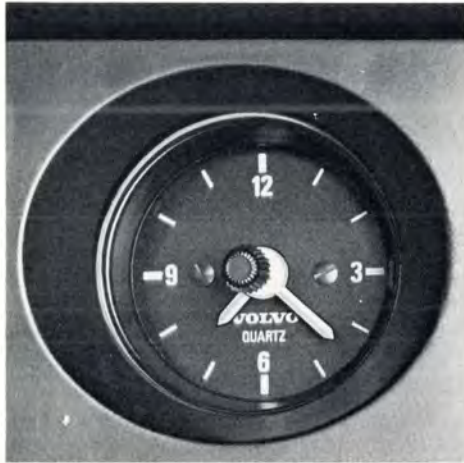

Quartz crystal clock

To reset the hands, push in the reset knob and turn.

Note: A slight ticking sound emitted by the clock is considered normal.



Cigarette lighter

Ash tray

Cigarette lighters

To operate, depress the knob fully. When the knob automatically releases, the cigarette lighter is ready for use.

The ignition must be switched on for the cigarette lighter to function.

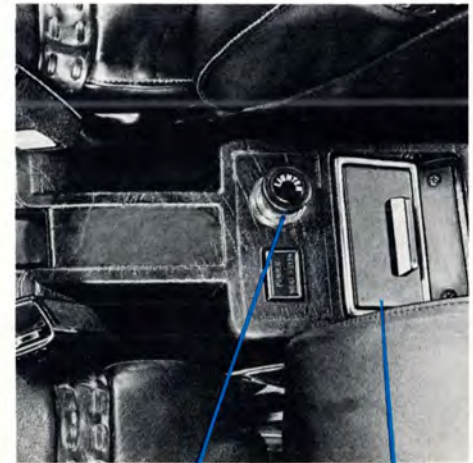

Cigarette lighter

Ash tray

Ash trays

To remove the ash trays depress the center spring and remove.

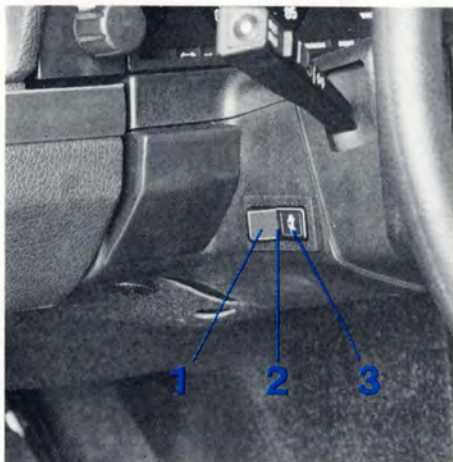

Interior light

There are two interior lights, one at each door. There are three switches, one on each lamp and one on the steering column.

Switch on steering column

- 1 Light is on when either of the doors are opened.
- 2 Light always out.
- 3 Light always on.

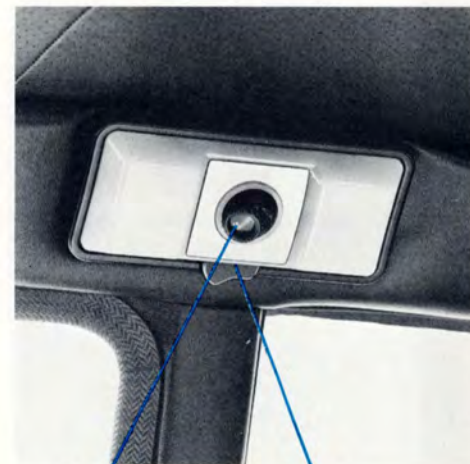

Spotlight
Switch
Lamp switches

To facilitate finding ignition lock, etc., during darkness a time delay device will illuminate the interior light for approx. 15 seconds after closing the driver's door (does not apply to the passenger's door).

These switches light the spotlight in the center of the interior light. It can be aimed as desired.

Radios, AM-FM-FM stereo-CB/Tape players, elect. operated antenna



Operating instructions

This optional equipment is available from Volvo Accessories in several different models, each with its own special features. Operating instructions are contained in the manuals associated with each model. These manuals are placed in the cars when the equipment is installed by the Dealer.

Your Volvo Dealer will be able to assist you with any questions regarding the operation of this equipment.

NOTE: Operation of Citizens Band (CB) radios is governed by Federal Regulations.

You must obtain a special license before operating this equipment. An application for a CB license is enclosed with each Volvo CB radio

Radio antenna mast

NOTE: Always lower the antenna mast when entering automatic car wash.

Seat height

There are two levers, each with three positions, for adjusting the height of the seat (front and/or back of cushion).

This allows adjustment of the seat cushion angle for added comfort.

After adjusting the seat, check that it is securely latched.

NOTE! Do not attempt to adjust seat height while seated.

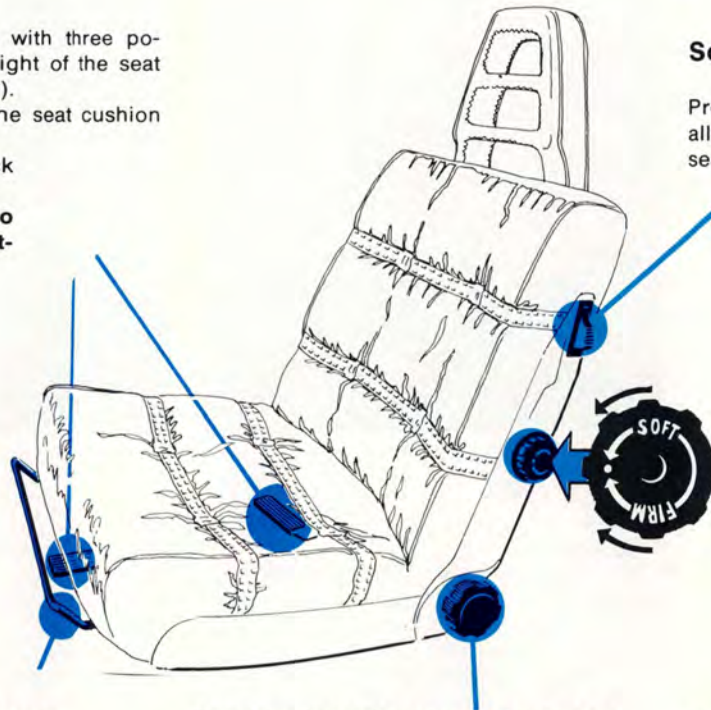

Seat back release

Press the button and fold seat back forward to allow passengers access to/from the rear seats.

Lumbar support adjustment

Horizontal seat adjustment

Pull control upward, then slide seat forward or rearward to desired position.

Make sure that seat is properly secured when you release the control.

Note: For your safety, never adjust seat while driving.

Seat back inclination adjustment

Rotate control clockwise to tilt seat back rearward.

Rotate counterclockwise to tilt seat back forward.

Note that body weight must be shifted to allow seat back to move forward.

Both front seats are electrically heated and are thermostatically controlled. Automatic engagement begins at 59°F (+15°C) and ends at 77°F (+25°C).

Observe that the passenger seat heater may be switched on/off by a switch on the instrument panel.

Seat belts



Release buttons, front seats

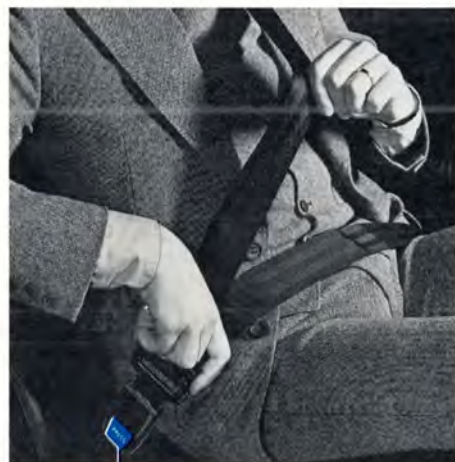

Release button, rear seats

Seat belts, retractable

Fasten the seat belts whenever you drive or ride.

Two lights will be illuminated for 4–8 seconds after the ignition key is turned to driving position. One light is located in the instrument cluster and one in the console between the front seats.

A buzzer will sound at the same time if the driver has not fastened his seat belt.

The front and rear outboard seats are provided with self-retracting inertia belts.

To buckle:

Pull the belt out from the retractor far enough to insert the latch plate into the buckle until a distinct snapping sound is heard. The belt should not be twisted or turned.

To unfasten, depress red pushbutton in buckle and let the belts rewind into their retractors.

The seat belt retractors are normally "unlocked". The retractors will lock up as follows:

- if belt is pulled out rapidly
- during braking and acceleration
- if the vehicle is leaning excessively
- when driving in turns

Check seat belt mechanism function as follows:

1 Attach the seat belt. Pull rapidly on the strap.

2 **CAUTION: Check other traffic before accomplishing this check.**

Brake firmly from approximately 30 mph (50 km/h) or turn in a tight circle while pulling on the belt.

In all the above checks you should not be able to pull the belt out.



Seat belts, manually adjustable

The center rear seat belt is manually adjustable. It should always be adjusted to the correct length.

To lengthen, angle the buckle as shown in the illustration and pull the belt through.

To shorten, pull the upper part of the double webbing until snug.

Maintenance

Check periodically that the anchor bolts are secure and the belt in good condition.

Use water and a mild detergent for cleaning.

As the seat belts lose much of their strength when exposed to violent stretching, they should be replaced after collision, even though they may appear to be undamaged. Never modify or repair the belt on your own, but have this done by a Volvo workshop.

Doors and locks

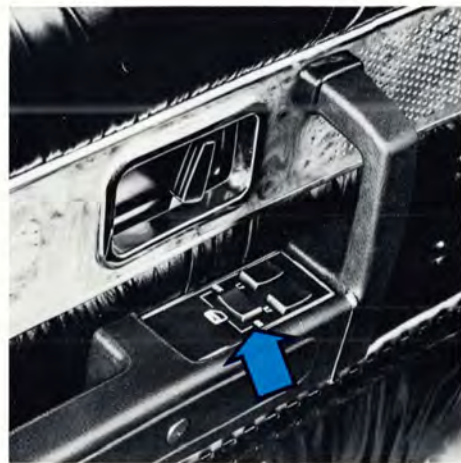

Control door locks

The vehicle is equipped with a central locking system. Locking/unlocking the driver's side front door will automatically control the other door.

Unlocking doors

Both front doors can be opened by the door key. Unlocking the driver's side front door will automatically control the right side front door. To open the doors from the inside, first the left part of the armrest switch must be depressed (position OFF) or the knob on the door pulled (pulling extra hard will also control the right front door).

Locking doors

Both doors are locked when the knob on the door is depressed.

To lock the doors when leaving the vehicle, depress the knob on the door (depressing extra hard will also lock the right front door) or depress the switch in the armrest (to position ON) before closing the door. Also the door key can be used to lock the door (locking the driver's front door will lock the right front door).

Switch, central lock

ON = locking both doors
OFF = unlocking both doors

The lock buttons should not be in the down position during driving. In case of an accident, this may hinder rapid access to the occupants of the vehicle.



Trunk lid

The lid can be opened by using the key. Open by turning the key $\frac{1}{4}$ turn, as shown.

The spare wheel, jack and tool kit are stowed in the left side of the trunk.

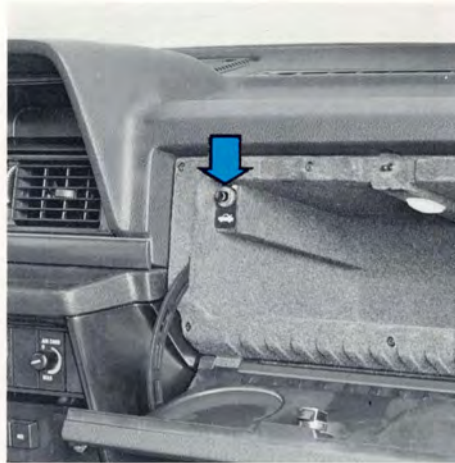

Electrically operated trunk lock

The trunk lock can be released electrically by actuating a pushbutton switch in the glove box.

- Depress switch to release lock.
- Closing trunk lid automatically resets the lock.

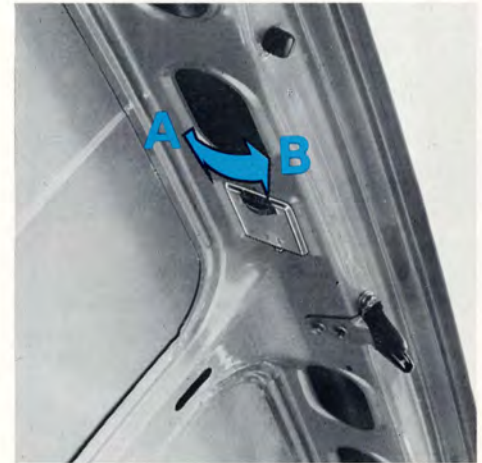

Trunk light

- A Light always off
- B Light is on when trunk lid is opened

Hood, fuel tank cap

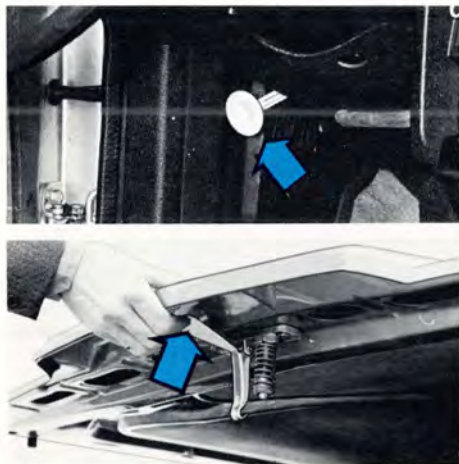

To open the hood

Pull the release handle (located under the left side of the dash).

Lift the hood slightly, insert a hand under the center line of the hood and depress the safety catch handle. Open the hood.

Check that the hood locks properly when closing.



Filling fuel

The gas cap is located behind the door on the right rear fender. Open slowly during hot weather conditions.

When filling, position the cap in the special bracket on the door.

After filling the tank, install the cap and turn until a "click" is heard.

Note: Unleaded fuel is required for all models. A label on the instrument panel and rear fender, near the filler inlet, will remind owners and filling station attendants of this requirement.

Important! It is unlawful to dispense leaded fuel into any vehicle labeled "unleaded gasoline only".

STARTING AND DRIVING

Service Inspection

To ensure proper operation the car should be taken to a Volvo dealer between the first 600 – 1,200 miles (1,000–2,000 km) for a service inspection. The oil in the engine, transmission and rear axle will then be changed. This is very important since the oil rapidly collects impurities during the break in period.

Break in period

A new car should be broken in!

Manual transmission

During the break in period do not exceed the following speeds:*

First 600 miles (1,000 km)

1st gear	20 mph	(30 km/h)
2nd gear	30 mph	(50 km/h)
3rd gear	50 mph	(80 km/h)
4th gear	70 mph	(110 km/h) ¹⁾

600 – 1,200 miles (1,000 – 2,000 km)

1st gear	25 mph	(40 km/h)
2nd gear	45 mph	(70 km/h)
3rd gear	60 mph	(100 km/h)
4th gear	80 mph	(130 km/h) ²⁾

Avoid driving at low speed in high gear.

¹⁾ 80 mph (130 km/h) with overdrive engaged. Do not use overdrive below 40 mph (65 km/h).

²⁾ 90 mph (150 km/h) with overdrive engaged.

* These are the maximum speeds recommended by the factory.

Note that legislation in different countries and states can stipulate other max. speeds than those given here.

Automatic transmission

Refrain from using "kick-down" when driving a car equipped with an automatic transmission during the first 1,200 miles (2,000 km).

Economical driving does not necessarily mean driving slow

Better driving economy may be obtained by thinking ahead, avoiding rapid starts and stops and adjusting the speed of your vehicle to immediate traffic conditions. Observe the following rules:

- Bring the engine to normal operating temperature as soon as possible by driving under light load. A cold engine uses more fuel and is subject to increased wear.
- When possible avoid using the car for driving short distances. This does not allow the engine to reach normal operating temperature.
- Drive carefully and avoid rapid acceleration and hard braking.
- Do not exceed speed limit.
- Avoid carrying unnecessary items (extra load) in the car.
- Check tire pressure regularly—cold tires.
- Remove snow tires when threat of snow or ice has ended.
- Note that roof racks, ski racks, etc., increase air resistance and thereby gas consumption.

Utilize the transmission to improve fuel economy.

Use correct gear!

- From first to second gear at approx. 10 mph (20 km/h)
From second to third gear at approx. 20 mph (35 km/h)
From third to fourth gear at approx. 30 mph (50 km/h)
- If vehicle is equipped with overdrive, use it at every opportunity (at speeds in excess of 45 mph = 70 km/h)
- Avoid using automatic transmission kick-down feature unless necessary.

Other factors which decrease gas mileage are:

- Worn or dirty spark plugs
- Incorrect spark plug gap
- Dirty air filter
- Incorrect valve clearance
- Incorrect idle speed
- Dirty engine oil and clogged oil filter
- Dragging brakes
- Incorrect front end alignment
- Low tire pressure

The above mentioned items and others are checked at the standard 7,500 Mile (12,500 km) Maintenance Service intervals.

Starting the engine

To start the engine:

- 1 Enter the car and fasten the seat belt.
- 2 Apply the parking brake, if not already set.
- 3 Place the gear selector lever in neutral. (position N or P, automatic transmission).
- 4 Depress the clutch pedal (manual transmission).
- 5 Without touching the accelerator pedal turn the ignition key to starting position. Release the key as soon as the engine starts.

If the engine does not start at once, depress the throttle pedal half way and keep it there until the engine starts.

Avoid repeated short attempts to start (fuel is injected every time the starter is engaged when engine is cold).

Allow the starter to operate for a longer time (but not more than 15 – 20 seconds).

Do not race a cold engine immediately after starting.

Engine warm-up—initial driving procedure

Experience shows that engines in vehicles driven short distances are subject to abnormally rapid wear because the engine never reaches normal operating temperature.

It is therefore beneficial to reach normal operating temperature as fast as possible.

This is achieved by driving under light load as soon as possible.

WARNING

Always open the garage doors fully before starting the engine inside the garage to ensure adequate ventilation. The exhaust gases contain carbon monoxide, which is invisible and odorless but very poisonous.



The overdrive light on the instrument panel goes on when the overdrive is engaged.

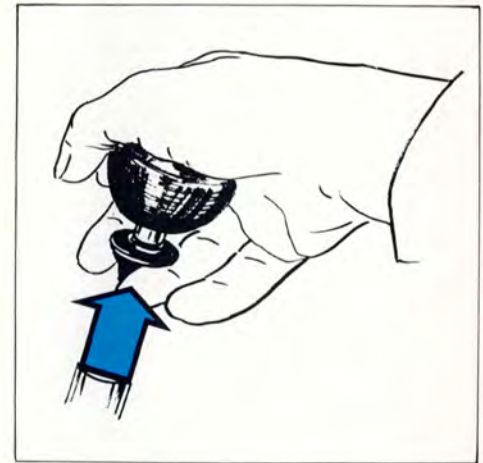

4-speed manual transmission

Depress the clutch fully when changing gears.

Overdrive (some models only)

Shift to overdrive at 45 mph (70 km/h) and disengage it when speed drops below 40 mph (65 km/h) or vehicle encounters hilly terrain. The overdrive can be engaged in 4th gear only. The overdrive is engaged by pressing in the switch on the top of the gear lever. If the switch is pressed in once again the overdrive will be disengaged. In addition the overdrive is disengaged when downshifting.

No extra operation of clutch or throttle pedal is normally necessary. **Engagement** is facilitated if the accelerator pedal position is maintained steady.

When **disengaging**, depressing the clutch pedal slightly makes a smooth transfer.

The overdrive should be used after the engine has reached normal operating temperature (minimum time is five minutes) and the vehicle is being operated on relatively level roads.

Downshifting to a lower gear will disengage the overdrive.

Reversing inhibitor

Lift the ring to enter reverse gear.

The ring locking mechanism prevents reverse gear from being engaged unintentionally.

Automatic transmission

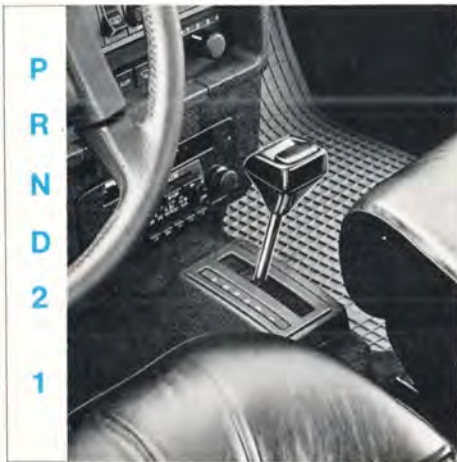

Shift positions

- P park
- R reverse
- N neutral
- D drive
- 2 intermediate
- 1 low

The gear selector can be moved freely between D and 2. The other positions are separated by a lockout which is operated by depressing the selector knob.

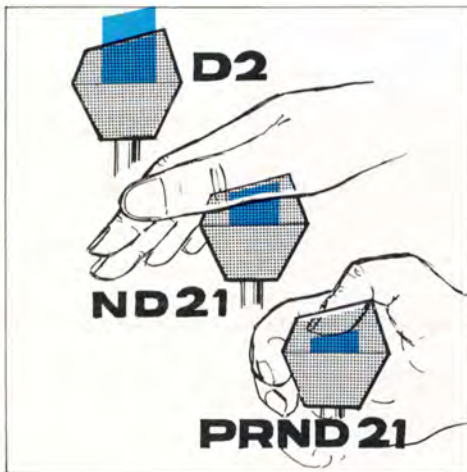

Shift gate

Depressing the selector knob slightly allows selection of positions **N** and **1**.

Depressing the selector knob fully allows selection of positions **R** and **P**. This is also necessary when initially bringing the selector out of position **P**.

Depressing the selector knob fully thus permits shifting freely between all positions.

P Park

Use this position when parked with the engine running or stopped.

Never use P while car is in motion.

The transmission is mechanically locked in position P. Also use the parking brake when parking on grades.

R Reverse

Never use R while car is moving forward.

N Neutral

Neutral position = no gear is engaged. Use parking brake.

Driving gears

D Drive

D is the normal driving position. Upshift and downshift of the three forward gears occurs automatically and is governed by throttle opening and vehicle speed.

2, intermediate position

Upshift and downshift of first two gears (low and intermediate) occurs automatically.

No upshift to 3rd (top) gear occurs.

Position 2 may be used to obtain forced downshift to 2nd gear for increased engine braking effect.

Position 2 can also be used ...

- For relatively slow highway driving.
- For city driving.
- When driving on mountain roads where precise speed control is desirable.
- For passing.

Kick-down

Automatic shift to a lower gear is achieved by depressing the throttle pedal briskly (passing the normal full throttle position).

An up-shift will be achieved when approaching the top speed for a particular gear or by releasing the throttle pedal slightly.

Kick-down can be used for maximum acceleration or when passing at highway speeds.

Starting and stopping a car equipped with automatic transmission

- 1 Fasten the seat belts.
- 2 Apply the parking brake or the brake pedal to hold the car (to prevent the car from moving when the gear selector is moved).
- 3 Select position **P** or **N**. (Engine cannot be started in any other position.)
- 4 Start the engine by turning the ignition key.
- 5 Select desired gear.
- 6 Release the brake and accelerate.

To stop the car, release the throttle pedal and apply the brakes.

It is not necessary to move the gear selector as the transmission will downshift automatically.

WARNING!

Always place gear selector in Park and parking brake set to ON before leaving vehicle.

1, low position

If position 1 is selected when driving at high speeds, 2 is engaged first and 1 when the speed has dropped to approx. 30 mph (50 km/h).

NOTE: No upshift once 1 is engaged.

Use position 1 to select low gear with no upshift. For instance, when entering and descending steep grades.

NOTE:

- **Never select P or R while the car is in motion.**
- **When initially selecting positions D, 2, 1 or R the car should be standing still with the engine idling.**
- **When traveling abroad or for police use the gear selector should not be downshifted to 2 or 1 at speeds above 75 mph (125 km/h).**

Emergency towing (pulling)

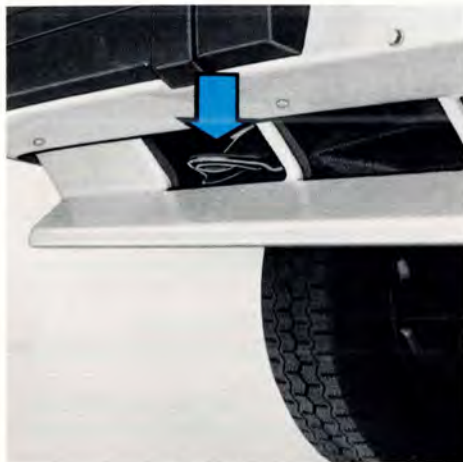

Front eyelet



Rear eyelet

Precautionary steps to observe when towing

- Steering must be unlocked.
- Observe legal speeds.
- Remember that power brake and power steering assists will not be available when engine is inoperative. Pedal pressure required is 3–4 times above normal and greater steering effort must be employed.
- **Towing cars equipped with automatic transmission:**
 - Gear selector in position N. Check transmission oil level (see section titled "Transmission oil").
 - Maximum speed: 20 mph (30 km/h).
 - Maximum distance: 20 miles (30 km).

Jump starting, see section titled "alternator, jump starting".

CARS EQUIPPED WITH AUTOMATIC TRANSMISSION CANNOT BE STARTED BY PUSHING OR PULLING THE CAR.

Towing information

FRONT

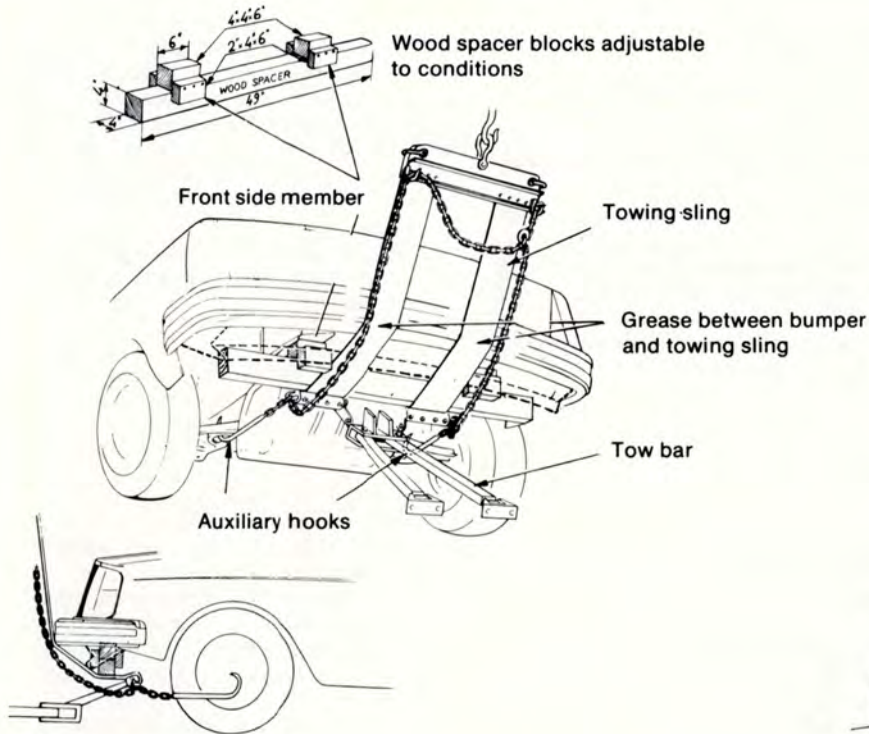

REAR

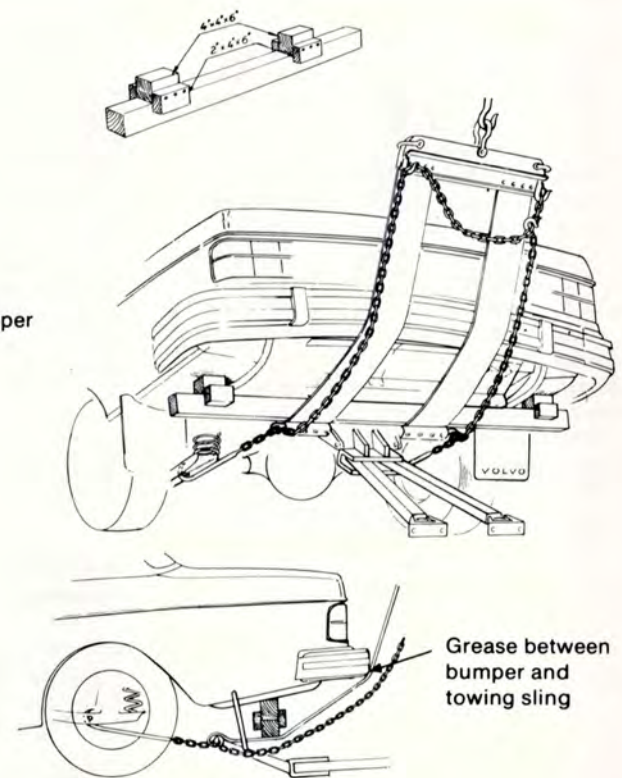

Trailer hauling

When preparing for trailer hauling, observe the following:

- Use a trailer hitch which meets Federal Safety Standards for rear end collisions (FMVSS 301-75) such as those offered as Genuine Volvo Accessories.
- Maximum trailer weight recommended by Volvo is 2 000 lbs (908 kgs). Observe legal requirements of the state in which the vehicles are registered. All Volvo models are equipped with energy absorbing shock mounted bumpers. Trailer hitch installation should not interfere with the proper operation of this bumper system.

WARNING:

Bumper mounted or installed trailer hitches should not be used on Volvo cars.

NOTE: Additional lighting equipment must be connected to specific points in the electrical system. Otherwise the bulb failure warning light will come on. (See your Volvo Dealer.)

Trailer hauling does not normally present any particular problems, but take into consideration:

- The hitch tongue load should not exceed 200 lbs (90 kgs).
- Engine and transmission are subject to increased loads.
- Avoid overload and other abusive operation.
- Hauling a trailer affects handling, durability and economy.
- It is necessary to balance trailer brakes with the towing vehicle brakes to provide a safe stop (check and observe State regulations).
- More frequent vehicle maintenance is required.

Remove the ball and drawbar assembly when the hitch is not being used.

WARNING: do not drive with trunk lid open!

Poisonous exhaust gases may enter via the open trunk lid.

If the trunk lid for any reason must be open, proceed as follows:

- Close the windows.
- Set the heating system controls FLOOR and DEF to max. and the blower to full speed (4). See section titled "Heating and Ventilation".

Handling, roadholding

Vehicle load, tire design and inflation pressure are important for proper handling. Therefore check that the tires are inflated to the recommended pressure according to the vehicle load.

It is recommended to use tires of the same make and dimensions on all four wheels.

CAUTION:

Do not mix radial ply and bias ply tires as this will adversely alter the vehicle handling characteristics.

Roof rack (removable)

Permanent and removable roof racks are available from Volvo Accessories.

Observe the following points when in use.

- Avoid point loads. Distribute the load evenly.
- Place the heavy cargo at bottom of load.
- Observe that center of gravity and handling are influenced by the load weight.
- Increasing load size increases wind resistance.
- Anchor the cargo correctly with a cord.
- Drive carefully. Avoid rapid starts, heavy cornering and heavy braking.
- Max. roof load is 220 lbs (100 kg).

The following "Special Tips" apply to cars with automatic transmission

- For steep hills and when driving for prolonged periods at low speeds position 1 should be selected. Avoid, however, repeated changes since this can cause overheating of the gearbox oil. For driving on mountain roads with long persistent uphill gradients, select position 2.
- When negotiating long, steep downhill slopes, position 1 should be selected and position 2 for less severe inclines, in order to obtain the best possible engine braking effect.
- Do not hold the car stationary on an incline by using the accelerator pedal, engage the handbrake instead. This prevents the gearbox oil from becoming overheated.
- When driving with heavy trailers, it is recommended that an additional oil cooler be installed. This applies especially when driving hard e.g. mountain driving or prolonged driving at high speeds without breaks. The additional oil cooler is available as a genuine Volvo accessory. Regarding oil change, see section titled "Transmission oil".

Moisture on brake discs and brake pads affects braking.

Driving in rain and slush or passing through a normal car wash can cause water to collect on the brake discs and pads. This will cause a delay in braking effect when the pedal is depressed. To avoid such a delay, when the brakes are needed, depress the pedal occasionally when driving. This will remove the water from the brakes. This should also be done after washing or starting in very damp weather.

If the brake power assist does not function –

The power assist to the brakes functions only when the engine is running. When the car is moving without the engine running the brake pedal pressure required to stop the car is increased 3–4 times.

The brake pedal feels stiff and hard.

Air dam (front spoiler)

An air dam can negatively influence the normal flow of cooling air to the front wheel brakes. Therefore, special light alloy wheel rims must be used in conjunction with the air dam. (See section titled "Wheels and Tires").

Failure in one of the brake circuits

The brake failure warning light goes on.



The pedal stroke increases slightly and the pedal feels softer but the pedal pressure required does not increase noticeably.

Drive cautiously to a Volvo dealer or Service Station to have the brake system checked.

Severe strain on the brake system

The brakes will be subject to severe strain when driving in mountains or hilly areas. The speed is usually low which means that the cooling of the brake is less efficient than when driving on level roads.

To reduce the strain on the brakes it is advisable not to use the brakes excessively. Instead, shift into a lower gear and let the engine help with the braking. A good rule is to use the same gear downhill as would be used uphill. For vehicles with automatic transmission use position 2 or in some cases 1.

Catalytic Converter

Catalytic Converter Cautions

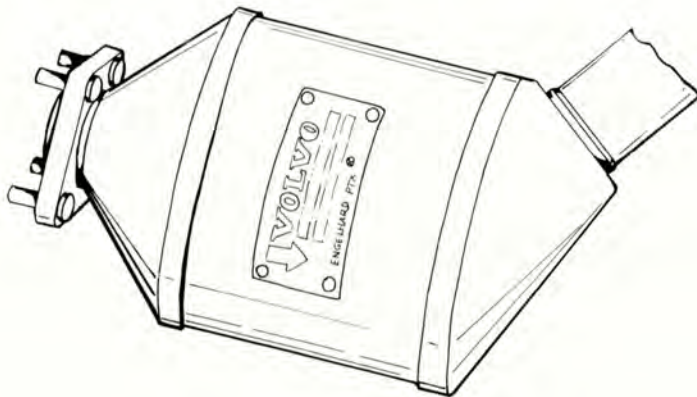

- Keep your engine properly tuned. Certain engine malfunctions, particularly involving the electrical, fuel or ignition systems, may cause unusually high converter temperatures. **Do not continue to operate your vehicle if you detect engine misfire, noticeable loss of power or other unusual operating conditions**, such as engine overheating, repetitive stalls or backfires. A properly tuned engine will help avoid malfunctions that could damage the Catalytic Converter.
- Remember that tampering or unauthorized modifications to the engine or the vehicle may be illegal and can cause catalyst or exhaust system overheating. This includes:
 - Altering fuel injection settings or components.
 - Adjusting ignition timing beyond specified limits.
 - Altering emission system components or location or removing components.
- Do not park your car over combustible materials, such as grass or leaves, which can come into contact with the hot exhaust system and cause such materials to ignite under certain wind and weather conditions.
- Excess starter cranking (in excess of one minute) with an intermittently firing or flooded engine, can cause catalyst or exhaust system overheating. This also applies to lengthy pushing or towing of vehicle to start (manual transmissions only).

NOTE: Unleaded fuel is required for cars with catalytic converter. A label on the instrument panel and rear fender, near the filler inlet, will remind owners and filling station attendant of this requirement. Important! It is unlawful to dispense leaded fuel into any vehicle labeled "unleaded gasoline only".

MAINTENANCE

Maintenance services

Your Volvo has passed two major inspections before it was delivered to you according to Volvo specifications. When driven 600–1,200 miles (1,000–2,000 km), your car should be brought to the Volvo dealer for a service inspection. Engine, manual transmission and rear axle oils, will be changed at this time.

Following this inspection, maintenance inspections as outlined in this book should be performed every 7,500 miles (12,500 km).

The extended maintenance inspection intervals make it even more advisable to follow this program.

Inspection and service should also be performed any time a malfunction is observed or suspected.

Retain receipts for all vehicle emission services to protect your emission warranty.

See your "Warranties and Maintenance Records Manual".

Maintenance inspection 7,500 mile (12,500 km) intervals

Volvo advises you to follow the inspection program at 7,500 mile (12,500 km) intervals which is outlined in the "Warranties and Maintenance Records Manual". This maintenance program contains inspections and services necessary for the proper function of your car over the next 7,500 miles (12,500 km).

The maintenance inspections contain several checks which require special instruments and tools and therefore must be performed by a qualified technician.

To keep your Volvo in top condition, specify time tested and proven Genuine Volvo Parts and Accessories.

THE FEDERAL CLEAN AIR ACT (USA)

The Clean Air Act requires vehicle manufacturers to furnish written instructions to the ultimate purchaser to assure the proper functioning of those components that control emissions.

The maintenance instructions listed in the "Servicing" section of this Manual represent the minimum maintenance required. These services are not covered by the warranty. You will be required to pay for labor and material used. Refer to your "Warranties and Maintenance Records Manual" for further details.

In accordance with Federal Regulations, your Volvo is warranted to meet certain Emission Performance Standards. Refer to your Warranties and Maintenance Records Manual for detailed information concerning:

- Emissions Performance Warranty
- Limited 12-Month New Car Warranty
- Limited 12-Month Replacement Parts and Accessories Warranty
- Extended Limited Warranty on Dealer Demonstrators
- Limited 5-Year/50,000 Mile Emission System Warranty

Note: The above pertains to USA vehicles only.

Gas station checks

Fuel

Octane rating 91 RON –87 (R+M)/2
Unleaded fuel must be used as the vehicles are fitted with catalytic converters.

Engine oil

Maintain oil level between the dipstick marks. The distance between the marks represents approx. 2 quarts (2 liters). Engine oil "**For API Service SE-CC or SF-CC**" SAE 10 W-40. (See section titled "Engine oil".)

Washer fluid

Washer fluid reservoir.
Water and solvent (wintertime use windshield washer anti-freeze).

Coolant

Maintain fluid level between MAX and MIN marks on expansion tank.
Mixture of 50 % Volvo anti-freeze Type A (red) or corresponding and 50 % water should be used.

Brake fluid Hydraulic clutch

Clutch fluid (only car with manual transmission).
Check that the level is above the MIN mark, without removing the cap.
Brake fluid DOT 4.

Battery

Electrolyte level $\frac{1}{4}$ " – $\frac{3}{8}$ " (5–10 mm) above plates.

Use distilled water only. **Never** add acid.

Warning: battery gases are explosive if brought in contact with open flame or sparks.

Low maintenance battery

Adding water not required under normal conditions. Check level in conjunction with normal service or once a year.

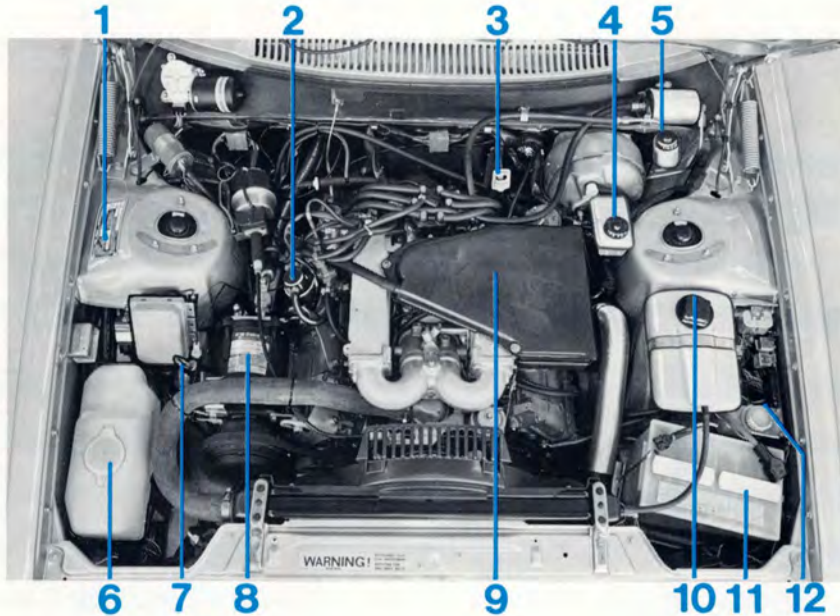

Engine B28F

- 1 Data plate
- 2 Oil filler cap, engine
- 3 Oil dipstick, automatic transmission
- 4 Brake fluid reservoir
- 5 Clutch fluid reservoir (cars with manual transmission)
- 6 Washer fluid reservoir
- 7 Oil dipstick, engine
- 8 Compressor (Air conditioner)
- 9 Air cleaner
- 10 Expansion tank, cooling system
- 11 Battery
- 12 Oil reservoir, power steering

Servicing

MAINTENANCE SCHEDULE

A = Adjust (Correct if necessary)
R = Replace

I = Inspect (Correct or Replace if necessary)
L = Lubricate

Maintenance Operation	Miles (Km)	600 – 1,200 (1,000 – 2,000)	7,500 (12,500)	15,000 (25,000)	22,500 (37,500)	30,000 (50,000)	37,500 (62,500)	45,000 (75,000)	Description on page
EMISSIONS SYSTEM MAINTENANCE									
Engine Oil and Oil Filter ¹⁾		R	R	R	R	R	R	R	45
Cooling System Hoses and Connections		I							46
Engine Drive Belts		A				I			46
Torque Manifold Nuts		A							47
Valve Clearance						I			47
Vacuum Fittings, Hoses and Connections		I							47
Oxygen sensor						R			48
Reset Service Indication System for Oxygen Sensor.						A			48
Air Cleaner Filter						R			49
Idle RPM		I ²⁾		I ²⁾		I ²⁾		I ²⁾	49
Spark Plugs						R			49
Fuel System Cap, Tank, Lines and Connections		I							50
Ignition Timing		I							51
Torque Catalytic Converter Mounting Bolts		A							52
Manual Transmission Oil		R	I	I	I	I	I	I	54
Automatic Transmission Oil ¹⁾		I	I	I	I	I ³⁾	I	I	55
Rear Axle Oil		R	I	I	I	I	I	I	56

¹⁾ Oil and oil filter cartridge are first changed at the 600–1,200 mile (1,000–2,000 km) inspection. Subsequent oil and filter changes should be made at 7,500 mile (12,500 km) intervals or **at least every sixth month**. However, adverse conditions (like hot ambient temperatures, trailer hauling, hill climbing, driving long distances at high speeds, extended periods of idling or low speed operation, short trip operation at freezing temperatures require oil changes more frequently (every third month).

²⁾ Not California model.

³⁾ For cars used for hard driving, or in hilly terrain etc, perform preventive service. This includes oil changes every 30,000 miles (50,000 km).

Maintenance Operation	Miles (Km)	600– 1,200 (1,000– 2,000)	7,500 (12,500)	15,000 (25,000)	22,500 (37,500)	30,000 (50,000)	37,500 (62,500)	45,000 (75,000)	Description on page
MISCELLANEOUS MAINTENANCE									
ENGINE									
Engine Coolant						R			46
Fuel (Line) Filter									50
PCV Nipple (Orifice)									51
Ventilation Hoses									51
BRAKES									
Inspect Brakes. Replace components if necessary.			I			I		I	56
Change Brake Fluid ¹⁾								R	56
STEERING									
Tire Wear (Align front end if needed.)		I	I	I	I	I	I	I	65
Check power steering fluid level.		I	I	I	I	I	I	I	56
BODY									
Trunk, Door and Hood Hinges and Latches.		L	L	L	L	L	L	L	57

¹⁾ For detailed information, see page 56.

Servicing

The following items should be checked weekly by the driver. (This only takes a few moments.)

Description on page

Engine oil level	45
Brake fluid	56
Radiator coolant level	58
Battery fluid level	40
Tire pressure	65, 85
Operation of all lights	9
Horns	4
Windshield wipers	71
Level of windshield fluid	12

The following should also be carried out at regular intervals.

Cleaning	70
Washing	70
Polishing	71
Rust protection	71

Engine oil



A oil dipstick
B oil filler hole

Checking engine oil level

The oil level should be checked each time the fuel tank is refilled. Be sure the oil level is maintained between the upper and lower marks on the dipstick. Low oil level can cause internal damage to the engine and overfilling can result in high oil consumption. The distance between the dipstick marks represents approx. 2 US qts=2 liters of oil.

To add or change engine oil

Add oil of the same kind as already used.

Capacity: 6.9 US qts=6.5 liters incl. filter.

Replace: Between first 600–1,200 miles (1,000–2,000 km) and every 7,500 miles (12,500 km) (or at least **every sixth month**).

Driving under adverse conditions such as high ambient temperatures, trailer hauling, hill climbing, driving long distances at high speeds, extended periods of idling, low speed operation or short trip operation at freezing temperatures may require oil and filter changes more frequently (every third month).

Drain the oil after driving while it is still hot.

Oil quality:

According to API Service { SE-CC
SF-CC

Synthetic or semisynthetic oils may be used if their specifications comply with the above.

Note! Oils with the designation SE-CD **must not** be used

Viscosity:

Temperature range ¹⁾		
Below 14°F (-10°C)	Between 14°F (-10°C) and 86°F (+30°C)	Above 86°F (+30°C)
SAE 10 W-40, 10 W-30 or 15 W-50		
SAE 20 W-50 ³⁾		
SAE 10 W		
SAE 20 W-20		
Footnote 2	SAE 30	

¹⁾ Refer to stable ambient temperatures.

²⁾ At very low temperatures (below -4°F = -20°C or when cold-starting difficulties are anticipated), multigrade oil SAE 5 W-20 or SAE 5 W-30 is recommended. These oils should **not** be used if temperatures persist above 32°F (0°C).

³⁾ SAE 20 W-50 should only be used during extreme driving conditions that involve high oil consumption. e.g. mountain driving with frequent decelerations or fast highway driving.



Changing oil filter

Replace the oil filter at every oil change. If the oil filter is changed separately, 1/2 US qt. = 0.5 liter of oil should be added.

Cooling system

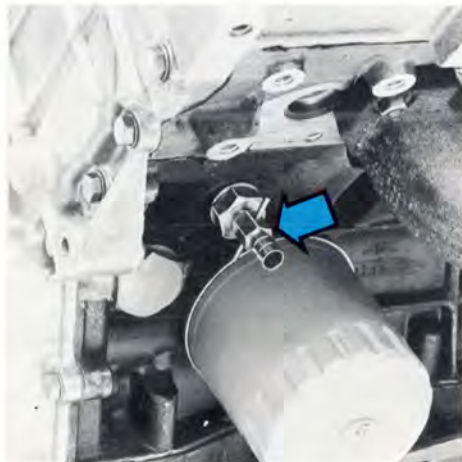

Changing coolant

Every two years or 30,000 miles (50,000 km) the cooling system should be drained, flushed and refilled.

Remove the expansion tank cap.

Open the drain cocks on both sides of the engine block and disconnect the lower radiator hose.

Fill coolant through the expansion tank.

The heater controls should be fully open when draining and filling.

Add coolant until the level is up to the MAX mark or slightly above.

Start engine and run until hot. Check the cooling system connections for tightness. Also re-check the coolant level.

Capacity: 11.5 US qts=10.9 liters.

Coolant: Volvo P/N 283240-0 or 283241-8.

Cooling system, hoses and connections

Check all cooling system hoses and connections for defects or deterioration of hoses and loose clamps or fittings.

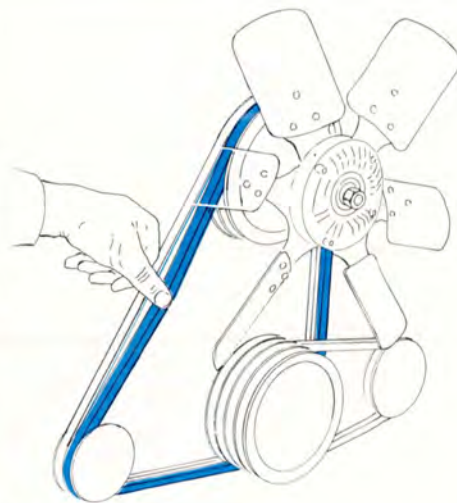

Drive belts

The belt tension can be checked by depressing the fan belt at a point midway between the alternator and fan. It should be possible to press down the belt about $\frac{1}{4}$ "– $\frac{3}{8}$ " (5–10 mm). This also applies to other drive belts on the engine.

Torque exhaust manifold nuts

The manifold nuts should be torqued at the 600–1,200 mile (1,000–2,000 km) inspection. A loose manifold could alter air/fuel ratio and cause an increase in emissions and/or poor driveability.

Valves

The valve clearance should be checked every 30,000 miles (50,000 km).

Vacuum fittings, hoses and connections

Unstable idle, misfiring or poor emission control is often caused by leaking vacuum hoses or connections. Check hoses and connections on distributor vacuum unit, connections on heater control servo systems and hydraulic brake servo.

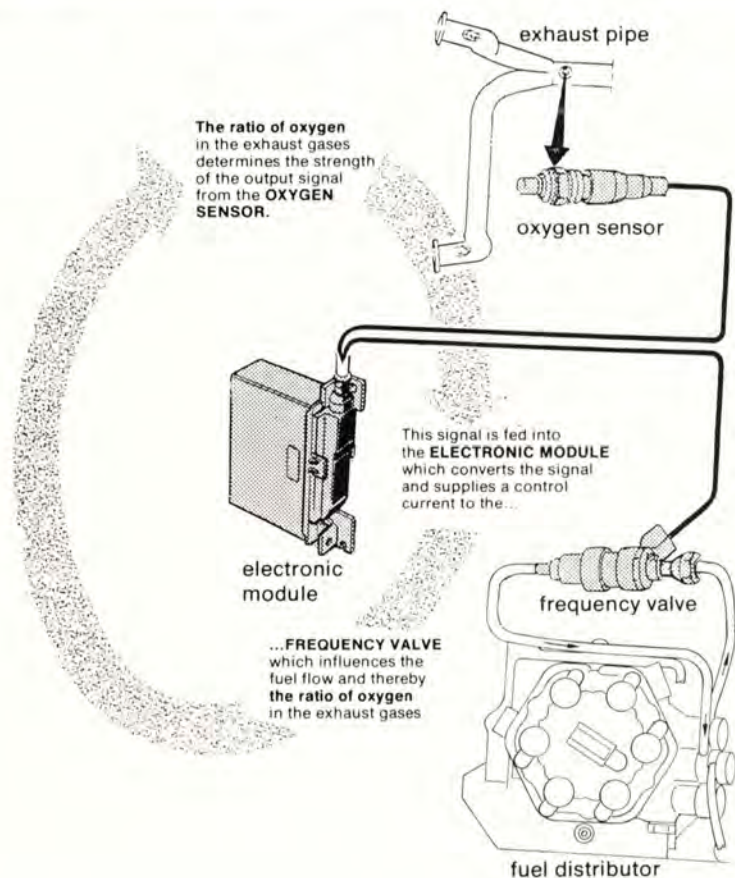

Lambda-sond™ (oxygen sensor) system

This is an emission control system designed to reduce emissions and improve fuel economy.

An oxygen sensor monitors the composition of the exhaust gases leaving the engine. The exhaust gas analysis is fed into an electronic unit which continuously influences a frequency valve. This adjusts the air-fuel ratio to provide optimum conditions for combustion and efficient reduction of the three major pollutants (hydrocarbons, carbon monoxide and nitrous gases) by a 3-way catalytic converter.

Change oxygen sensor unit and reset service indication for oxygen sensor

The oxygen sensor must be replaced every 30,000 miles (50,000 km).

To remind the driver about the change of the oxygen sensor unit there is a special reminder light. (See section titled "Warning Lights".) The light will stay on until reset.

Note:

Failure to follow the recommended maintenance may result in vehicle not meeting Federal or state emissions standard.

Air cleaner

Replace the air cleaner cartridge with a new one every 30,000 miles (50,000 km). The cartridge should be replaced more often when driving under dirty and dusty conditions. The filter cannot be cleaned and, therefore, should always be replaced with a new one.

Checking and adjusting idling speed

This check should be made every 15,000 miles (25,000 km). California vehicles are equipped with a constant idle speed system that require no check or adjustment.

Change spark plugs

The spark plugs should be changed every 30,000 miles (50,000 km).

However, city driving or fast highway driving may require changing after 7,500 miles (12,500 km) of driving. When fitting new plugs, be sure to fit the right type (Volvo Part No. 273593-4 or Bosch HR6 DS). Torque to 7–10 ft.lbs. (10–14 Nm).

When changing the plugs, check that the suppressor connectors are in good condition. Cracked or damaged connectors should be replaced.

When changing spark plugs, clean the cables and cable terminals, also the rubber seals. If the car is driven on roads where salt is used during the winter, coat the cables with silicone.

Servicing

Fuel system cap, tank and lines, and connections

The effectiveness of the fuel system to contain hydrocarbons is largely dependent on a leak-free system. Check for proper sealing of gasoline filler cap which contains "O" ring type seals. Check all evaporative hoses in vehicle for tightness. Check fuel lines under vehicle and repair if necessary.

Fuel 91 octane RON –87 (R+M)/2

Unleaded fuel is **required** for models with catalytic converter (all models). A label on the instrument panel and on the rear fender, near the filler inlet, will remind of this requirement.

It is unlawful to dispense leaded fuel into a vehicle labeled "unleaded gasoline only".

Special instructions for work on the fuel injection system

Extreme cleanliness is essential when working on the injection system. Great care must be observed.

Injection system service should be handled by qualified technicians, using equipment intended for this service.

CI system

The B28F engine is provided with a fuel injection system called the CI system (Continuous Injection). Fuel injectors are open and inject fuel as long as the engine is operating.

This system has few moving parts, is reliable and meets the exhaust emission standards at maximum efficiency.

Air supplied to the engine is continuously measured and determines the amount of fuel injected.

The air flow is regulated by two throttle valves. The air flow sensor and the fuel distributor are integrally built as a single unit. A lever is actuated by the air flow to produce continuous fuel distribution.

Fuel (line) filter

The fuel filter is located on the firewall. This filter is to be changed every 50,000 miles (80,000 km). The filter is replaced as one complete unit.

Replace more frequently if contaminated fuel was introduced into the tank.

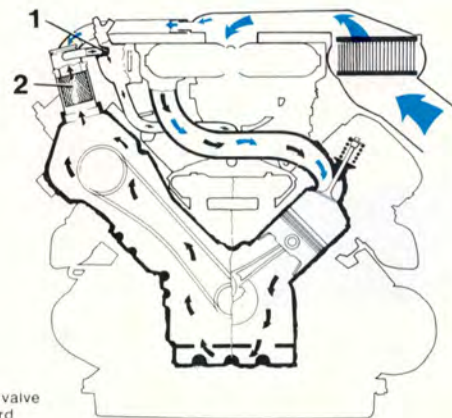

Ignition timing

The ignition timing should be inspected at the 600–1,200 mile (1,000–2,000 km) inspection. All adjusting work should be done with the proper equipment. The distributor is one of the most sensitive engine units. Careless handling can lead to decreased engine output and high fuel consumption or even serious damage to the engine.

Crankcase ventilation

The engine is provided with positive crankcase ventilation which prevents crankcase gases from being released into the atmosphere. Instead, the crankcase gases are admitted to the intake manifold and cylinders.

Cleaning PCV valve

The calibrated positive crankcase ventilation valve should be cleaned every 60,000 miles. Rubber hoses should be checked for damage at the same time. Replace if necessary.

Servicing

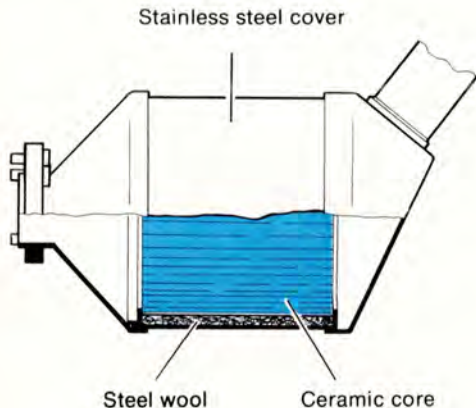

Catalytic converter

This is a supplementary device in the exhaust system, designed to clean the remaining dirty exhaust gases.

This device is mainly a container with a ceramic material insert, designed to let the exhaust gases pass through channels in the insert. The channel walls are covered by a thin layer of platina-palladium. These metals act as catalysts, permitting a chemical action to occur without actually taking part in it.

The CO content will increase if the Catalytic Converter is damaged.

Lambda-sond™ equipped vehicles use Catalytic Converters containing platinum and rhodium.

Torque catalytic converter mounting bolts

The Catalytic Converter mounting bolts should be torqued at 600–1,200 miles (1,000–2,000 km).

CAUTION:

Vehicles with Catalytic Converter must use unleaded fuel only. Otherwise the Catalytic Converter will become ineffective.

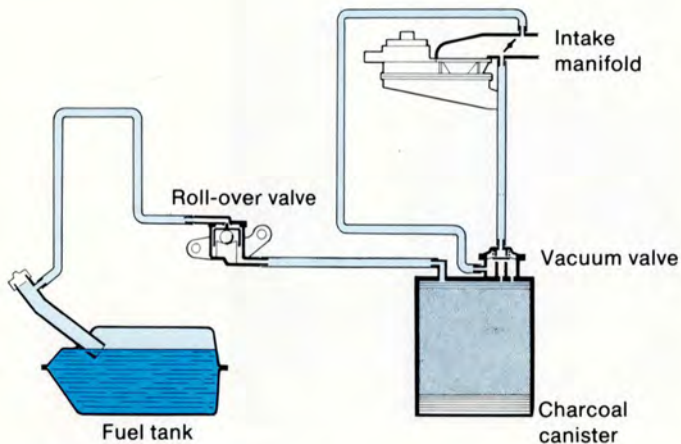

Evaporative control system

Vehicles intended for the North American market are equipped with a gas evaporative control system, which prevents gasoline fumes from being released into the atmosphere.

The system is comprised of an expansion chamber in the fuel tank, a roll-over valve on the cross member in front of the fuel tank, and a charcoal canister with built-in vacuum valve under the left front wheel housing.

The components are interconnected by hoses which channel fuel vapor from the gas tank to the charcoal filter where it is stored until the engine is started and then drawn into the engine fuel induction system.

Transmission oil

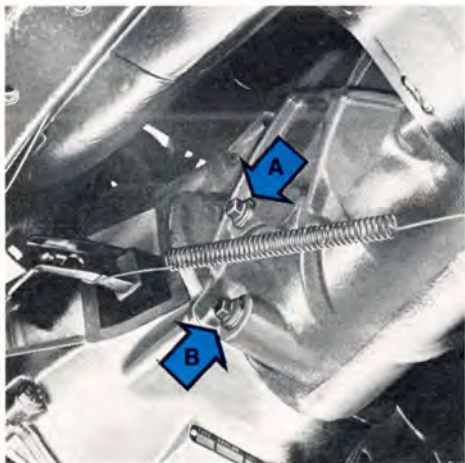

Manual 4-speed transmission with overdrive, M46

Capacity: 2.4 US qts=2.3 liters.

Fluid type: Automatic Transmission Fluid type F or G (FLM)

Replace: at 600–1,200 mile (1,000–2,000 km) service only.

The oil level should be up to the filler plug (A). Drain the oil immediately after driving, while it is still hot by removing plug (B).

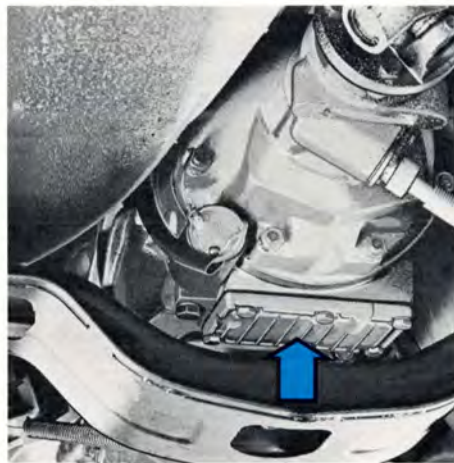

Transmission and overdrive are lubricated by the same oil. Therefore, when the oil is drained through plug B, also remove cover on the overdrive and clean strainer.

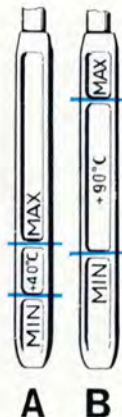

Automatic transmission

- Capacity: 7.3 US qts=6.75 liters.
Fluid type: Automatic Transmission Fluid type F or G (FLM)
Replace: no oil changes necessary under normal driving conditions.

Driving under adverse conditions such as trailer hauling, driving long distances at high speeds etc. should have the oil changed every 30,000 miles (50,000 km). If an additional oil cooler has been installed this oil change is not necessary.

(See also section titled "Trailer hauling".)

A Cold gearbox oil – oil temperature +105°F (+40°C).

This is a normal temperature for the transmission after idling for about 10 minutes.

At oil temperature below +40°C, the level may be below the MIN mark.

B Warm gearbox oil – oil temperature +195°F (+90°C).

This temperature is obtained when driving for about 30 minutes.

At oil temperature above +90°C, the level may be above the MAX mark.

Note!

The engine should be idling when checking transmission fluid level.

Check the oil level as follows:

Park the car on level surface with the engine idling.

Slowly move the selector lever through all the gear positions and then to position P. Wait 2 minutes before checking the oil level. As the illustration shows, the dipstick has a "cold" and "warm" side. The oil level should be between the MIN and MAX marks.

Wipe the dipstick with a clean cloth. CAUTION! The oil may be very hot!

Do not use rags which can leave lint on the dipstick.

The transmission is topped up via the dipstick tube.

The space between the MIN and MAX marks on the dipstick corresponds to 0.5 liter. Do not fill the transmission with too much oil, since this can result in oil being ejected from the transmission.

Too little oil, on the other hand, can negatively affect transmission operation, particularly in very cold weather.

Rear axle, power steering, brake fluid

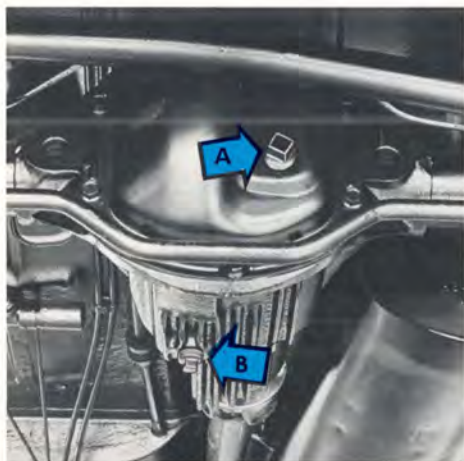

Rear axle

Capacity: 1.7 US qts=1.6 liters.
Oil type: API GL-5 (MIL-L-2105 B or C)
Viscosity: SAE 90
Replace: at 600–1,200 mile (1,000–2,000 km) service only.

The oil level should be up to the filler plug (A). Drain rear axle oil through drain plug (B). When the temperature is steadily below 15°F = -10°C, use API GL-5 SAE 80 W oil. Cars equipped with limited slip differentials should use oils with proper additives.



Power steering

Capacity: 1.25 US qts=1.2 liters.
Fluid type: ATF
Replace: no fluid change required.

The level should be between the MAX and MIN marks.

Check fluid level with engine idling and after driving while the fluid still is hot. Wipe the reservoir clean.

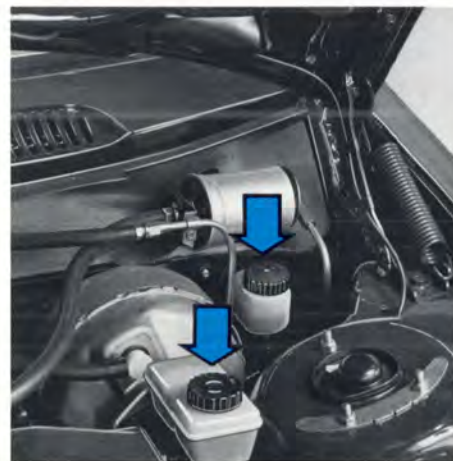

Brake fluid/Clutch fluid (only on cars with manual transmission)

Fluid type: DOT 4
Replace: every third year or 45,000 miles (75,000 km). The brake fluid should be replaced once a year or every 15,000 miles (25,000 km) for cars equipped with air dam. The clutch fluid does not need to be changed.

Check, without removing the cap, that the level is above the "MIN" mark of the fluid reservoirs.

Always entrust brake fluid changing to a Volvo dealer.

Change brake fluid every year when driving under extremely hard conditions (mountain driving etc).

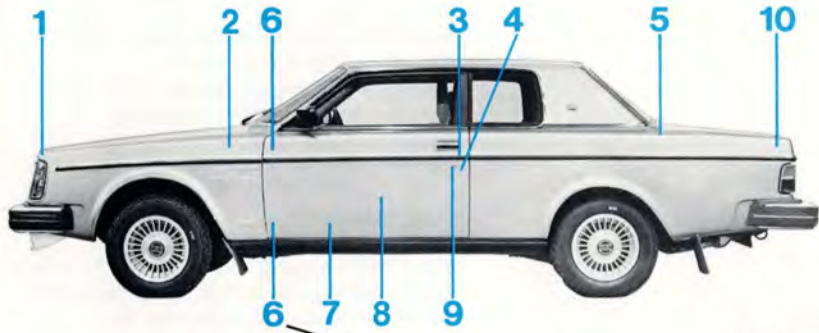

Door hinges and door stop



A Grease
B Oil

Chassis maintenance

To simplify maintenance, your Volvo has been equipped with ball joints, steering rods and propeller shafts that do not require regular lubrication.

Points that normally require lubricating have been packed with very durable grease at the factory and then carefully sealed, eliminating the need for subsequent lubrication.

Lubricate body

To avoid rattles and unnecessary wear, the body should be lubricated once a year. Hinges on hood, doors and trunk lid as well as door stops should be lubricated every 7,500 miles (12,500 km).

During winter, locks in the doors and trunk lid should be treated with special anti-freeze lubricant to prevent freezing.

No. Lubricating point

Lubricant

1 Hood lock	Paraffin wax
2 Hood hinges	Oil
3 Door lock outer sliding surfaces	Paraffin wax
4 Striker plate	Paraffin wax
5 Trunk lid hinges	Oil
6 Door hinges	Grease
Door stop	Oil
7 Front seat slide rails and latch devices	Oil
8 Window regulator	Oil, grease
Locking device (Accessible after door upholstery panels removed)	Silicon grease
9 Key holes	Lock oil
10 Trunk lid lock	Lock oil

Coolant



Check coolant level

The cooling system must be filled with coolant and not leak to operate at maximum efficiency. Check the coolant level when filling fuel. The level should be between the "Max" and "Min" marks on the expansion tank. The check should be made with particular thoroughness when the engine is new or the cooling system has been drained.

Do not remove the filler cap other than for topping-up with coolant. Frequent removal may prevent coolant circulation between the engine and the expansion tank during engine warming up and cooling.

Top up with coolant

Top up with coolant by filling the expansion tank when level is at the "Min" mark. Use a mixture of 50 % anti-freeze/summer coolant and 50 % water all the year round. Top up to the "Max" mark.

If the engine is warm, and you are going to top up coolant, unscrew the cap slowly in order to allow any excess pressure to escape.

NOTE: Do not top up with water only. Water by itself reduces the rust-protective and anti-freeze qualities of the coolant and has a lower boiling point. It can also cause damage to the cooling system if it should freeze.

Cooling system

The risk for overheating is greatest, especially in hot weather, when:

- towing a trailer up steep inclines for prolonged periods at full throttle.
- idling for prolonged periods while the air conditioning system is in operation.
- stopping the engine suddenly after high-speed driving, so-called after-boiling.

To avoid overheating, the following rules should be followed.

- Reduce speed and change down when towing a trailer up long steep inclines. The risk of overheating can be reduced by switching off the air conditioning system for a short while.
- Do not let the engine idle unnecessarily.
- Do not stop the engine immediately after high-speed driving, but allow the engine to idle for 1/2-1 minute before switching off.

When the risk of overheating is imminent, or in the event of overheating, (the temperature gauge goes repeatedly into, or stays continually in, the red section) the following precautions should be taken:

- Switch off the air conditioning system.
- Stop the car and put the gear lever into neutral position-position N. **Do not stop the engine!**
- Increase the engine speed to approx. 2000 r/min (twice idling speed).
- Check the level of coolant in the expansion tank. Top-up, if necessary.

Note:

This car is equipped with an alternator

When changing the battery or when carrying out work involving the electrical system, the following should be observed.

- 1 A battery connection to the wrong terminal will damage the diodes. Before connections are made, check the polarity of the battery with a voltmeter.
- 2 If booster batteries are used for starting, they must be properly connected to prevent the diodes from being damaged.
For correct connection, see next section, titled jump starting.
- 3 If a fast charger is used for charging the battery, the battery leads should be disconnected.
- 4 Never disconnect the battery circuit (for example, to change the battery) while the engine is running, as this will immediately ruin the alternator.
Always make sure that all the battery connections are properly tightened.
- 5 If any electrical welding work is performed on the vehicle, the ground lead and all the connecting cables of the alternator must be disconnected and the welder wires placed as near the welding point as possible.

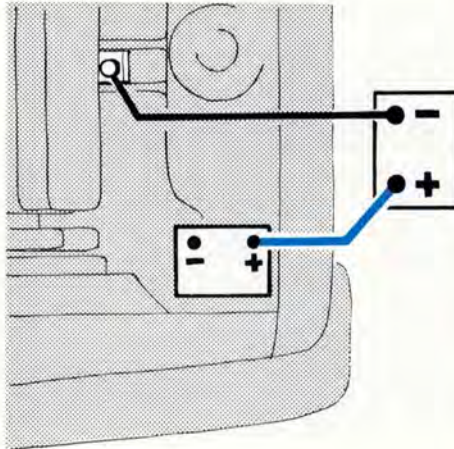

Jump starting

CAUTION: Improper hook-up of jumper cables could result in damage to equipment and/or battery.

Check that cars are not touching. (To prevent premature completion of negative circuit). Using jumper cables, first connect booster battery positive terminal (+) to car battery positive terminal (+). Then connect booster battery negative terminal (-) to a stationary solid metal part on the engine at a point away from the battery. Do not connect to any part of fuel system or any moving parts. Avoid touching hot manifolds.

WARNING!

To prevent possible explosion, never expose battery to open flame or electric spark. Do not smoke near battery. Batteries generate hydrogen gas which is flammable and explosive.

Battery fluid contains sulfuric acid. Do not allow battery fluid to contact eyes, skin, fabrics or painted surfaces. If contact occurs, flush affected area immediately with water.

Obtain medical attention if eyes are affected.

After engine has started remove negative terminal (-) jumper cable first then positive terminal (+) jumper cable.

Replacing bulbs

Replacing bulbs

The replacement of bulbs in the various lighting units is shown on the following pages. Make sure when installing bulbs, that the guide pin on the socket fits into its corresponding recess.

When installing bulbs, do not touch the glass with your fingers. The reason for this is that grease, oil or any other impurities can be carbonized onto the bulb and damage the reflector.

Use bulbs of correct type and voltage. Failure to do so could activate the bulb failure warning light.

Replacing sealed beam headlamp units

- 1 Press the two plastic screws down and turn them $\frac{1}{4}$ turn and remove them.
- 2 Lift up the rim slightly and remove it forwards.
- 3 Remove the Phillips screws and rim. Lift out the headlamp unit.
- 4 Disconnect the socket contact.

Installation is done by reversing the procedure.

Check headlight alignment.

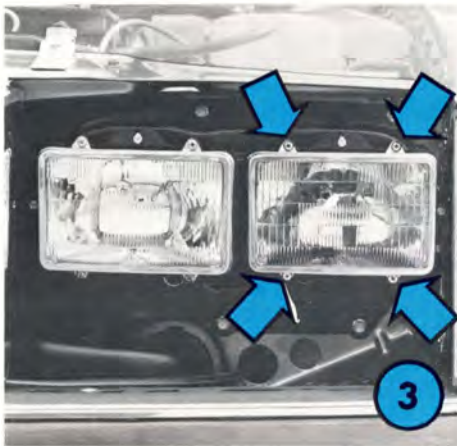
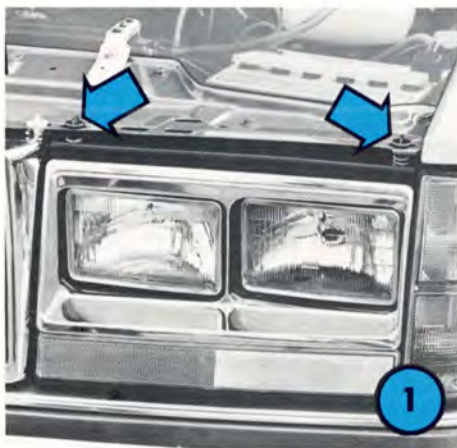

Replacing bulbs

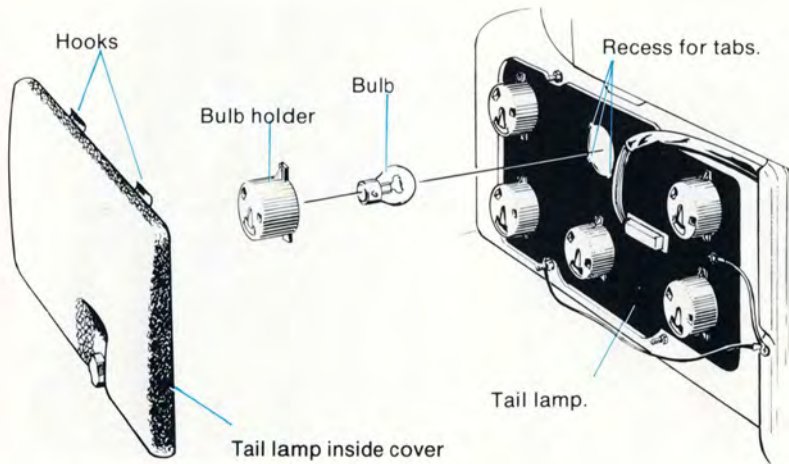

Tail lamp bulbs

All tail lamp bulbs are replaced from inside of trunk.

- 1 Unscrew and remove tail lamp inside cover. Note that inside cover is hooked at the upper edge. Lift the lower end out/up and unhook upper edge.
- 2 Turn bulb holder approx. $\frac{3}{8}$ " counterclockwise and remove it.
- 3 Depress bulb in bulb holder, turn it slightly counterclockwise, and remove it.
- 4 Install a new bulb. Install bulb holder in tail lamp. NOTE: One of the bulb holder tabs is wider and fits only in the corresponding recess. Turn the bulb holder clockwise. Check that bulb illuminates. Replace tail lamp inside cover.

Bulbs	Power CP (W)	Socket	US Bulb No
1 Stop light	32 (21)	Ba 15 s	1073
2 Back up light	32 (21)	Ba 15 s	1073
3 Rear turn signal	32 (21)	Ba 15 s	1073
4 Tail light	4 (5)	Ba 15 s	67
5 Reflector	—	—	—
6 Tail light, side marker light	4 (5)	Ba 15 s	67

Replacing bulbs



Front light bulbs

Loosen the Phillips screws and remove the lens. The bulbs can now be removed by pressing them inwards and turning them slightly counterclockwise.

When re-installing lens, check that the gasket is in position.

Bulbs	Power CP (W)	Socket
1 Front position, Side marker lights	4 (5)	Ba 15 s ¹⁾
2 Front turn signal	32 (21)	Ba 15 s ²⁾

¹⁾ US Bulb No 67

²⁾ US Bulb No 1073



License plate light

Insert a screwdriver as shown and carefully pry loose the lamp housing. Take care not to damage the paint. Pull out the lamp housing and replace the bulb. Insert the front edge of the lamp housing and press up the rear edge by hand.

Bulbs	Power	Socket
License plate light	4 W	Ba 9 s

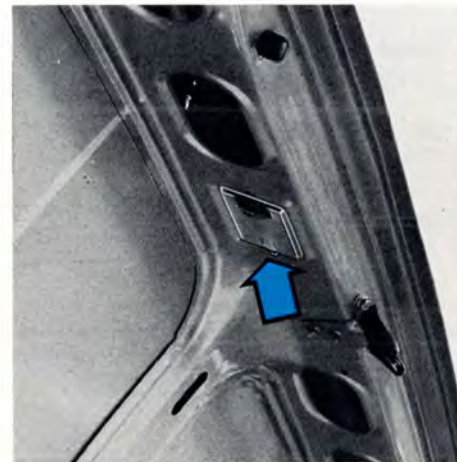

Trunk light

Remove screw holding the light assembly. Lift out and to the right to remove.

Replace the bulb.

Reinstall by first inserting the guide into the left side, then press in the light assembly and install the screw.

Bulbs	Power	Socket
Trunk light	15 W	S8,5-8

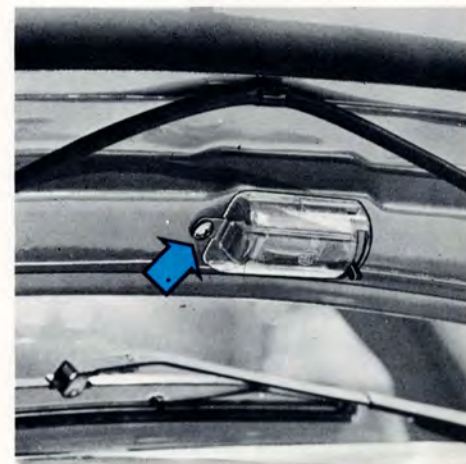

Interior light with spotlight

To remove the lens, squeeze it at the points shown using your fingers and lift out one edge at a time.

When installing the lens, make sure the recess for the spotlight switch is pointing downward.

Bulbs	Power	Socket	No. of bulbs
1 Interior light	5 W	S 8,5-8	2
2 Spotlight	4 W	Ba 9 S	1

Engine compartment light

Remove the screw holding the lamp and lift it to the right.

Replace the bulb.

To install the lamp, first insert the guides on the right side in the recess, then press in the lamp and install the screw.

Bulbs	Power	Socket
Engine compartment	15 W	S8,5-8

Replacing bulbs for instrument lighting and heater control lighting

Due to the location of the bulbs, their replacement should be carried out by a Volvo dealer.

Fuses

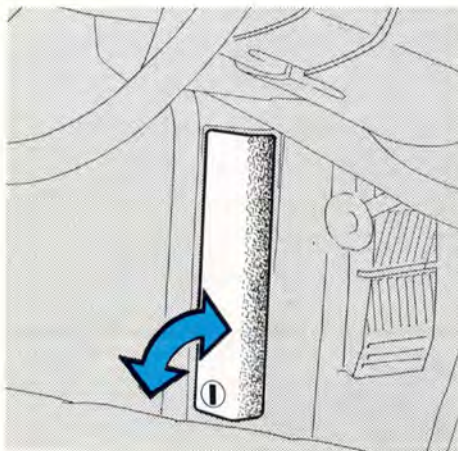

Replacing fuses

The fuse box is positioned in front of the left front door pillar.

When replacing fuses, check that right amperage is used.

Never use fuses of higher amperage. If one fuse repeatedly fails, take the car to your Volvo dealer for fault-tracing.

WARNING!

Turn ignition switch OFF before replacing fuses. Excessive heat may be created by a short circuit. Care must be exercised while replacing blown fuses.



17 Fuse storage, spare

1	Cigarette lighter	8 A
	Electrically operated side mirrors	
	Radio (optional)	
	Cruise control	
2	Window wiper/washer	16 A
	Horn	
3	Heater blower	25 A
4	Seat belt warning	8 A
	Ignition key buzzer	
5	Fuel feed pump	8 A
6	Brake light	8 A
	Relay, interior light	
7	Fuel pump	16 A
8	Interior light	8 A
	Glove box light	
	Clock	
	Trunk light	
	Engine compartment light	
	Central locking	
	El. radio antenna	
9	Hazard warning flashers	8 A
10	Elect. op. windows	16 A
	El. heated passenger seat	
11	Overdrive	16 A
	Rear window demist	
12	Back-up lights	8 A
	Relay, window lifts	
	Heated driver's seat	
	Air conditioning	
13	Instruments	8 A
	Turn signals	
	Seat belt warning light	
	Temperature warning light	
	Relay, fuel injection	
14	Spare	
15	Parking light, left side	8 A
	License plate light	
16	Parking light, right side	8 A
	Light on instruments and controls	
	Buzzer, headlights and key	

Checking and correcting tire pressure

Check the tire pressure when refueling.

The tire pressure should only be corrected when the tires are cold.

With warm tires, correct only when the pressure is too low. The tire temperature rises after driving just a few miles.

Tire pressures, cold tires, psi (kPa)

Tire	Recommended tire infl. pressure cold tires, psi						Vehicle capacity weight
	Normal speed				>75 mph		
	1-3 pers.		Full load				
	Front	Rear	Front	Rear	Front	Rear	
185/70 R 14	27 (190)	27 (190)	28 (200)	32 (230)	28 (200)	32 (230)	770
Space saver spare	36 (250)	36 (250)	36 (250)	36 (250)	-	-	

See Consumer Information Booklet for complete tire pressure information.

Space saver spare tire max. speed 50 mph.

Examples of tire wear

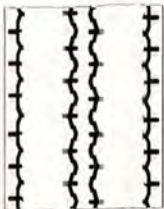

Underinflated

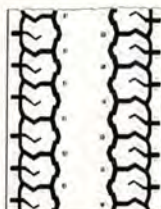

Overinflated

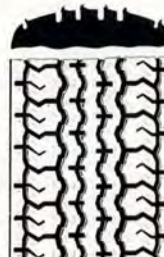

Wrong toe-in

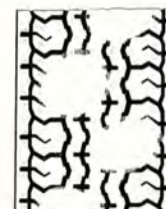

Unbalance

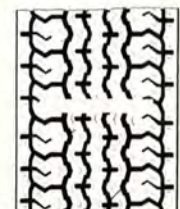

Wear indicator exposed.
Tire is worn, replace.

Wear indicator

The tires have a so-called "wear indicator" in the form of a number of narrow strips running across or parallel to the tread. When approx. $\frac{1}{16}$ " = 1.5 mm is left on the tread, these strips show up and indicate the tire should be replaced.

Tires with less than $\frac{1}{16}$ " tread have a very poor grip in rain or snow.

How to improve tire economy

- Maintain correct tire pressure.
- Drive smoothly: avoid fast starts, hard braking and tire screeching.
- Tire wear increases with speed.
- Do not change wheel location unless necessary.
- Correct front wheel alignment is very important.
- Unbalanced wheels impair tire economy and driving comfort.
- Hitting curbs can damage the tires permanently.

Wheels and tires

Winter Season

Radial snow tires are recommended for winter driving.

Tire **chains** can be used on the rear wheels if the chains do not project too far from the tire and chafe against the brake caliper or other components.

Strap-on emergency chains must not be used since the space between the brake caliper and the wheel rim is inadequate.

WARNING!

Air dam (front spoiler)

Air dams can negatively influence the normal flow of air to the front wheel brakes. Therefore, special light alloy wheel rims or steel wheel rims of 1980 or 1981 year models+ ventilated brake disks at the front wheels must be used in conjunction with the air dam.

Special wheel rims

Only special wheel rims, tested and approved by AB Volvo, are suitable for use with air dams.

Spare tire

To save trunk space, the car has been equipped with a space saver spare tire. The tire is intended for temporary use only and is stored deflated. To fill with air, there is a special air compressor which may be connected to the cigarette lighter receptacle. When used, the spare tire should be inflated to 36 psi.

The air valves include a safety valve which protects the tire from over-inflation. Tire and rim comprise a unit which should not be separated. Replace as a unit at a Volvo dealership in case the spare tire is damaged.

NOTE:

The tire should be used only in place of a deflated (flat) tire and is intended only for driving to a repair shop where the damaged tire can be repaired or replaced.

Maximum speed is 50 mph=80 kmh.

Keep in mind that because of its simple design the tire tread pattern does not provide optimum driveability.

Air compressor

The air compressor has no switch and will start when connected to the cigarette lighter receptacle. If it does not start when plugged in, check fuse No. 1 first and then the tobacco residue in the receptacle.

Do not use the air compressor for periods longer than 20 minutes as it will overheat. Allow cooldown between periods.

Do not inflate the spare tire to pressures higher than 36 psi.



Installing spare tire

- 1 Lift the car and remove the defective wheel.
 - 2 Install the space saver spare tire.
 - 3 Connect the air compressor hose to the tire valve.
 - 4 Route the electrical cable through the side window to avoid damage to the cable and plug it into the cigarette lighter receptacle.
 - 5 Inflate to 36 psi (in middle of gauge between graduations 2 and 3). Disconnect the air compressor and install the tire valve cap.
 - 6 Lower the car and retighten the wheel nuts alternately.
- Drive to nearest repair shop and have the spare tire replaced by the repaired or replaced original. Deflate the spare tire.

Wheel changing

To observe when replacing wheels

To avoid re-balancing, mark and re-install wheels in same location and same position as before removal.



Changing a wheel

Spare wheel, jack and tool kit are stowed in the trunk compartment. Before raising the car with the jack be sure it is on firm and level ground.

NOTE: Do not crawl or work under the car while it is raised by the jack.

Before the car is raised with the jack the parking brake should be applied and first or reverse gear engaged. With automatic transmission, the selector should be in **Park**. Block one of the wheels on the opposite side of the car from the jack.

Removal

The wheel cap can be removed with the tommy bar or the screwdriver provided in the tool kit.

Loosen the wheel nuts $\frac{1}{2}$ –1 turn with the box wrench provided in the tool kit. All of the wheel nuts have right-hand threads which are loosened by turning them counter-clockwise.

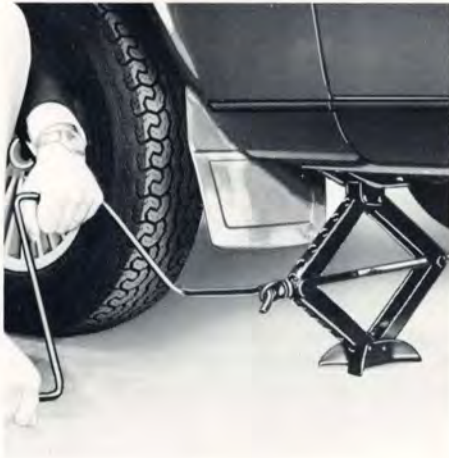

Insert the lifting arm of the jack in the jack attachment closest to the wheel to be changed.

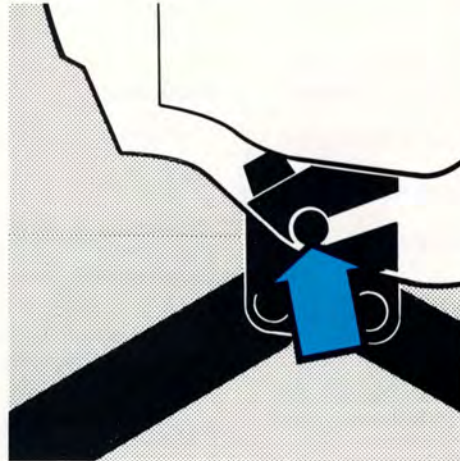

Be sure the arm goes all the way into the attachment.

Raise up the side of the car enough to lift the wheel off the ground.

Unscrew the wheel nuts completely and remove the wheel carefully so as not to damage the threads of the studs.

WARNING!

- Never crawl under a car supported by a jack.
- Use the jack intended for the car when replacing a wheel. For any other job use stands to support the end of the car being worked on.
- Apply the parking brake, engage first or reverse gear (pos. P for cars equipped with automatic transmission).
- Block the wheels standing on the ground. Use rigid wooden blocks or large stones.
- The jack should stand on firm, level ground.

Installation

- Clean the contact surface between wheel and hub.
- Lift on the wheel and fit the wheel center on the hub shoulder.
- Tighten the nuts until the wheel makes good contact with the flange.
- Lower the car and tighten the nuts alternately to 72 – 100 ft.lbs. (100 – 130 Nm)
- Install the wheel cap.

NOTE: Do not rotate a raised rear wheel if the car is equipped with a limited slip differential. This will also move the opposite wheel on the ground and the car may slide off the jack.

Body care

Body care

To avoid corrosion, especially when salt and chemicals are being used on the roads, the car should be washed as soon it becomes dirty.

- Wash off the dirt on the underside (wheel housings and fenders etc).
- Soften the dirt on surface finishes with water.
- Wash off the dirt with a sponge, using plenty of water. Warm but not hot water is recommended.
- In case of sticky dirt a water soluble grease solvent may be used.
- Rinse with clean water.
- Dry carefully with a soft clean chamois cloth.
- Open up drain holes in doors and bottom rails.

NOTE: Test the brakes immediately when driving to remove water.

Decoration mouldings should be cleaned with polish (do not use rubbing compound or steel wool). For chromed parts use commercially available chrome cleaners.

Machine washing

Hand washing is superior to carwash machine washing. However, if machine washing, remember to lower the antenna mast.

We recommend that you do not wash your car in an automatic wash during the first six months (because the paint will not have hardened sufficiently). If automatic car washing is essential use only reputable establishments.

Cleaning the upholstery

To clean **leather upholstery**, use soft cloth and mild soap solution, for instance common bath soap.

For more difficult spots, consult an expert for the choice of cleaning agent.

When aging, leather changes appearance, but the typical texture remains. To preserve smoothness and appearance, it is recommended

to treat the leather with a special leather preservative after one or two years of use.

Seat belts

Clean only with mild soap solution and lukewarm water.

Floor mats

The floor mats should be vacuumed or brushed clean regularly, especially during the winter when they should be taken out for drying. Spots on textile mats can be removed with a household detergent.

For plastic or leather upholstery never use gasoline, kerosene or similar cleaning solutions. The material will be damaged.

Polishing (waxing)

Polishing and waxing are not necessary unless a glossy surface can no longer be obtained by normal car washing.

Normally polishing is not required during the first year after delivery, however, waxing may be beneficial.

Before applying polish or wax the car must be washed and dried. Tar spots can be removed with kerosene or tar remover. Difficult spots may require a fine rubbing compound.

After polishing use liquid or paste wax.

Several commercially available products contain both polish and wax. Waxing alone does not substitute for polishing of a dull surface.

Anti-rust treatment

Your Volvo has been rust protected at the factory. On external surfaces a heavy coat of wear resistant material has been used, while on the internal surfaces a lighter rust protector is used.

The external rust protection should be inspected regularly or at least once per year. If the rust protection has been penetrated a repair

should be made as soon as possible to prevent moisture from entering between the metal and coating. Carefully clean and remove any rust prior to repair of the rust protective coating.

The internal rust protection should be renewed first time after 36 months and then at least every 24th month.

See your Volvo dealer for additional information.

What causes rust

The two most common causes of rust to your car are:

1. The accumulation of road dirt and moisture in hard-to-get-at cavities and other areas under the car:
2. The removal of paint and protective coatings on the outside of the car and underneath through damage by stones and gravel or minor accidents.

Several factors influence the speed at which corrosion will occur:

1. The length of time various parts of a car stay wet. Parts of the car filled with road dirt and water remain damp for long periods of time even when other parts are dry.

Particular attention should be paid to the underside of the car and floor sections inside.

The floor sections stay wet because moisture collects and remains under the floor matting.

Drain holes located at the bottom of the doors get clogged with dirt, trapping water inside the door and causing the door to rust through at the bottom.

2. Corrosion will be accelerated in areas of higher relative humidity, especially where temperatures often stay above the freezing point and where the atmosphere is affected by industrial pollution, or where salt is used for de-icing the roads.

Where parts of the car are covered with road dirt containing road salt, corrosion will be accelerated at a lower relative humidity than if the surface were clean.

3. Increased temperature will cause an accelerated rate of corrosion of those parts of the car which are not well ventilated to permit quick drying.

4. Industrial pollution and the presence of salt will also accelerate the deteriorations of paint finishes.

The foregoing identifies the need for every car owner to keep the car and particularly the underside, as clean and dry as possible and to repair any minor damage to paint work and protective coating as soon as possible.

The need is more important in those localities where road salt is used for de-icing, the relative humidity is higher, air pollution is present and temperatures regularly stay above freezing.

Replacing wiper blades

Fold the wiper arm outward. Press the metal tab upwards (1) and pull the wiper blade upwards (2). Push on the new wiper blade and **check for correct attachment.**

NOTE:

For improved driving safety, replace the wiper blades when they start to wipe inefficiently.

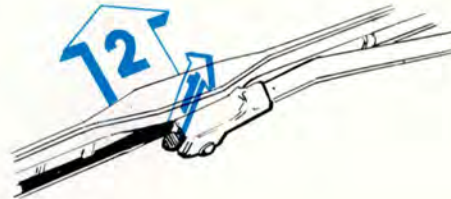

Paint touch-up

Paint touch-up

Paint damage requires immediate attention to avoid rusting. Make it a habit to check the finish regularly, for instance when washing the car. Touch-up if necessary.

Paint repairs require special equipment and skill. Contact your Volvo dealer for any extensive damages.

Minor scratches can be repaired by using Volvo touch-up paint.

NOTE: When ordering touch-up paint from your Volvo dealer, use the paint code indicated on the service label. The label is located on the wheel housing in the engine compartment.

Minor stone chips and scratches

Material:

Rust remover

Primer—brush on type

Surface finish—brush on type

(The paint pen head also contains grinding paste for subsequent treatment.)

Penknife or similar

Brush

NOTE: When touching-up the car, it should be well cleaned and dry and have a surface temperature above +15°C (60°F).

Scars on the surface (where the paint has not been completely penetrated). Repairs can be made directly after light scraping to remove dirt.

Deep scars, (down to the bare metal):

- 1 Scrape or sand the damaged surface lightly and break the edges of the scar.

Apply the rust remover. (Avoid contact with eyes and skin!). Wait a few minutes and then rinse carefully with water and wipe dry.

- 2 Thoroughly mix the primer and apply it with a small brush.

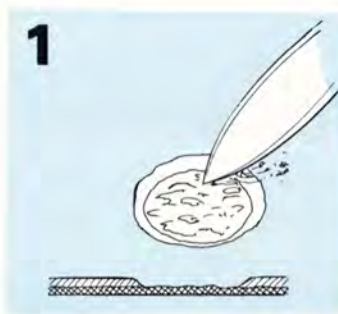

Paint code

VOLVO		MADE IN
	kg	
	kg	
1-	kg	
2-	kg	

When the primer surface is dry, the paint can be applied using a brush.

Mix the paint thoroughly, apply several thin paint coats and let dry after each application.

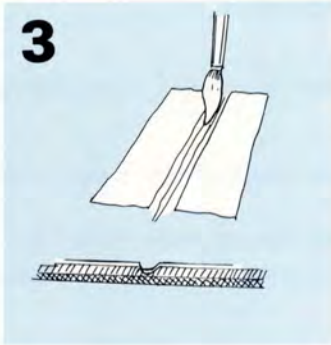

3 If there is a longer scratch, you may want to mask to protect surrounding paint.

Touching-up damaged paint on fender edges and sills

Material:
Rust remover
Primer – spray
Surface finish – spray
Sand paper (H 150 – 300 grit)
Thinner

NOTE! When touching-up the car, it should be well cleaned and dry and have a temperature exceeding + 15°C (60°F).

Mask with tape and paper prior to painting larger surfaces. Remove the masking immediately after application of the last paint coat, before the paint starts to dry.

Touching-up is as follows:

- 1 Remove paint flakes.
- 2 Sand the damaged surface and wash it clean with thinner.
Apply the rust remover. (Avoid contact with skin!) Wait a few minutes and then rinse carefully with water and wipe dry.

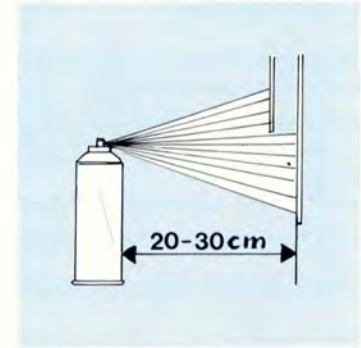

- 3 Shake the spray can for at least 1 minute. Spray on the primer. Move the can slowly and evenly back and forth over the spot and about 20–30 cm (8–12 in.) from the surface. Protect the surrounding surfaces with suitable paper.

NOTE! Spray painting should be done in a well ventilated and dust-free area.

- 4 When the primer has dried, apply the surface enamel in the same way. Spray on several times and allow the paint to dry a minute or so between each application.

Winter precautions, preparations for long distance trips

Winter precautions

The following precautions should be taken to avoid unnecessary trouble when cold weather is due.

- 1 Make sure cooling system contains approx. 50 % anti-freeze and 50 % water which will lower the freezing point to approx. -31°F (-35°C).
See page 46 for instructions on how to replace coolant.
- 2 Keep the fuel tank as full as possible to prevent condensation from forming.
Also use a reliable additive (drygas) to the fuel. Add before filling gas.
- 3 Use light oils for the engine, see recommendations page 44.
- 4 The battery is subject to additional strain in wintertime. Electrical components are used more extensively and cold weather will lower the battery capacity.
Check battery condition and apply grease to the terminal posts.
- 5 In cold and slushy weather, avoid using the parking brake as it might freeze. Place transmission in park and/or block the wheels instead.
- 6 Fill windshield washer reservoir with non-freezing cleaner. The washer will be used more frequently and it is important to keep it from freezing.
- 7 Lubricate the door locks with appropriate lock fluid.

Preparations for long distance trips

Have the car checked prior to a long distance trip.

It is a good idea to have a supply of important spare parts (bulbs, fuses, etc.).

Observe following:

- Check that the engine operates correctly and that the fuel consumption is normal.
- Check engine and drive line for leaks (oil, coolant, fluid, fuel).
- Check condition and tension of drive belts. Replace worn belts.
- Check battery condition.
- Check the tires, including the spare tire. Fill air or replace as necessary.
- Check brakes, wheel alignment and steering.
- Check lights.
- Check tools, jack and other equipment required.
- Check all fluid levels.

The diagnosis outlined below is only intended to serve as a guide to locate and temporarily correct minor faults. Causes for unsatisfactory performance should be investigated and corrected by your Volvo dealer.

NOTE: The points indicated by an asterisk (*) should be checked by your Volvo dealer.

Condition: Starter fails to operate (or operates very slowly)

Possible cause	Correction
Weak battery or dead cell.	With the ignition switch in the "Driving" or "On" position, check to see if the warning lights on the dashboard come on and if they stay on when the starter is engaged. If the lights do not come on or if they go off when the starter is engaged, the battery is discharged or see below.
Loose or corroded battery cable terminals.	Check battery terminals and clamps. Clean or replace if necessary. Check that the starter cable is secure at its terminals. The ground strap, which connects the body to the rear of the engine, should also be checked for corrosion or looseness.
Open circuit between ignition/starter switch and ignition terminal on starter.	The circuit is closed if a clicking sound is heard from the starter when it is engaged. If no clicking sound is heard, check that the blue wire at the starter is secure. If still no clicking sound is heard, the ignition switch or the wire is defective.
Starter motor defective.	If the above checks have been performed, and no fault is evident, the starter may be defective. NOTE: In this case the headlight intensity will not dim when the starter is engaged.

Service diagnosis

Condition: Starter motor operates but engine does not start

Possible cause	Correction
Intake system leaking.	Check vacuum hose connections at manifold and auxiliary air valve.
No fuel reaching engine.	Check for fuel in the tank. Check fuse No 5, 7 and 13.
No spark.	Remove one spark plug wire and unscrew the radio interference suppressor. Hold the wire approx. $\frac{3}{8}$ " (10 mm) from the valve cover and run the starter. If there is no spark, check that the high tension lead from the coil to the distributor cap is connected and that the wires to the distributor and coil are connected.
Spark plugs, high tension leads or distributor cap wet or defective.	Clean the parts with a dry cloth or spray with a moisture remover. Replace defective or worn parts.
Cold start injector defective.	Test the cold start injector function with cold and hot engine.*
Rest pressure incorrect.	Test rest pressure and the fuel system for leaks.* If no fault is found following the above steps, contact your Volvo dealer.

* Should be checked by a Volvo dealer.

Condition: Erratic idle (misfiring)

Possible cause	Correction
Intake system leaking.	Check vacuum hose connections at manifold and auxiliary air valve.
Spark plugs, high tension leads or distributor cap worn (defective).	Clean distributor cap and leads, check the cap for cracks. Replace defective or worn parts.
Worn spark plugs.	Remove. Clean or replace spark plugs.
Cold start injector leaking.	Test the injector function.*
Uneven compression.	Test compression.*

Condition: Engine stalls at irregular intervals

Possible cause	Correction
Defective wires.	Check wire terminals at: fuel pump, fuse No. 5 and 7, coil, distributor, ignition switch and relays.
Intake system leaking.	Check vacuum hose connections at manifold and auxiliary air valve.
Low idle speed.	Adjust.*
Fuel filter clogged.	Clean fuel tank filter and replace fuel line filter.

* Should be checked by a Volvo dealer.

Service diagnosis

Condition: Low top speed, loss of power

Possible cause	Correction
Air filter clogged.	Check air filter.*
Throttle misadjusted.	Check that the throttle touches the high speed stop when the accelerator is fully depressed.*
Incorrect timing.	Check and adjust.*
Fuel filter clogged.	Clean fuel tank filter and replace fuel line filter.*

Condition: Excessive fuel consumption

Possible cause	Correction
Fuel lines leaking.	Check tightness.
Spark plugs worn.	Replace plugs.
Incorrect timing.	Check/adjust.*
Air filter clogged.	Check/replace.*
Control pressure incorrect.	Check/replace control pressure regulator.*
Cold start injector leaking.	Replace injector.* (A leaking cold start injector also causes uneven idle and hard starting.)

* Should be checked by a Volvo dealer.

Condition: Dieseling

Possible cause	Correction
Injector leaking.	Check air flow sensor plate and rest pressure.*

Condition: Misfiring at highway driving

Possible cause	Correction
Spark plugs fouled.	Drive the vehicle in a lower gear and keep the engine rpm higher for a few miles in order to remove carbon deposit on the spark plugs. If this procedure is not effective, clean or replace the spark plugs.

* Should be checked by a Volvo dealer.

Dimensions and weights

Length	192.5" (489 cm)
Width	67.3" (171 cm)
Height, curb weight	53.9" (137 cm)
Wheelbase	104.3" (265 cm)
Track, front	56.3" (143 cm)
rear	53.5" (136 cm)
Turning circle (between curbs)	32.5" (9.8 m)
Curb weight (depending on type)	3105–3115 lbs (1410–1415 kg)
Gross vehicle weight (GVW)	4070 lbs (1830 kg)
Capacity weight	770 lbs
Permissible axle weight, front	1980 lbs (900 kg)
rear	2180 lbs (990 kg)
Max. trailer weight	2000 lbs (908 kg)
Max. hitch load	200 lbs (90 kg)

Capacities

Fuel tank	15.8 US gals=60 liters
Cooling system	11.5 US qts. = 10.9 liters
Oil capacity,	
engine, at oil change	6.9 US qts.=6.5 liters
excl. oil filter	6.3 US qts.=6.0 liters
transmission (M46)	2.4 US qts.=2.3 liters
(BW55)	7.1 US qts.=6.75 liters
rear axle	1.7 US qts.=1.6 liters
steering gear, power	1.25 US qts.=1.2 liters

Specifications

ENGINE

Liquid-cooled, gasoline, 6-cylinder V-engine with 90° angle. Aluminum cylinder block with cast iron, replaceable wet liners. Aluminum cylinder head has separate inlet and exhaust passages. Single, overhead camshafts.

Engine lubrication is provided by a gear pump driven from crankshaft. Full-flow type oil filter. Exhaust emission control accomplished by fuel injection, Lambda-sond™ system and catalytic converter. Closed crankcase ventilation system and evaporative emission control system.

Type designation

Volvo B28F

Output (SAE J 245) at rpm	130 hp (97 kW)/5500
Max. torque (SAE J 245) at rpm	153 ft.lbs. (208 Nm)/2750
Number of cylinders	6
Bore	3.58" (91 mm)
Stroke	2.87" (73 mm)
Displacement	2.85 liters
Compression ratio	8.8:1
Valve clearance cold engine	
inlet	0.004–0.006" (0.10–0.15 mm)
exhaust	0.010–0.012" (0.25–0.30 mm)

Cooling System

Type	Positive pressure, closed system
Thermostat-begins to open at	188°F (82°C)
-fully open at	207°F (97°C)
Fan belts, designation	HC-38 × 1100
Coolant: Volvo P/N 283240-0 or 283241-8	

Fuel system

The engine is equipped with continuous fuel injection system.

Ignition System

Firing order	1-6-3-5-2-4
Ignition setting	
stroboscope setting with vacuum regulator disconnected, AC off	10° ± 2° B.T.D.C. (at 700-800 rpm) (Calif. models 900 rpm)
Spark plugs	Volvo P/N 273593-4 (Bosch HR6 DS)
Spark plug gap	0.028-0.032" (0.7-0.8 mm)
Tightening torque	7-10 ft.lbs. (10-14 Nm)
Distributor, direction of rotation	Clockwise

ELECTRICAL SYSTEM

12 V, negative ground.
Voltage-controlled alternator. Single-wire system with chassis and engine used as conductors.

Voltage	12 V
Battery, type	Low maintenance**
Capacity	70 Ah
Electrolyte, specific gravity	1.28
Recharge at	1.21
Alternator, rated output	980 W
max. current	70 A

** Volvo P/N 1235266

Lights, 12 V	US bulb No.	Power	Socket	No. of bulbs
Headlights, inner	4×6½" Type 1A1	Sealed Beam		2
Headlights, outer	4×6½" Type 2A2	Sealed Beam		2
Position Lights, front	67	5 W/4 cp	Ba 15 s	2
Turn Signals, front	1073	21 W/32 cp	Ba 15 s	2
Turn Signals, rear	1073	21 W/32 cp	Ba 15 s	2
Tail Lights	67	5 W/4 cp	Ba 15 s	2
Stop Lights	1073	21 W/32 cp	Ba 15 s	4
Back-up Lights	1073	21 W/32 cp	Ba 15 s	2

The following bulbs may be obtained from your nearest Volvo dealer:

Rear Ash Tray Light	1.2 W	W 1.8 d	1
License Plate Light	4 W	Ba 9 s	2
Interior Light	10 W	S 8.5-8	4
Spotlight	4 W	Ba 9 s	2
Glove Box Light	2 W	Ba 9 s	1
Instrument Panel Light	2 W	Ba 7 s	3
Control Panel Light	1.2 W	W 1.8 d	3
Shift Positions,			
Auto Transmission	1.2 W	W 1.8 d	1
Engine Compartment			
Light	15 W	S 8.5-8	1
Trunk light	15 W	S 8.5-8	1
Warning Lamps			
Charging	1.2 W	W 1.8 d	1
Turn Signals	1.2 W	W 1.8 d	2
Brake Failure	1.2 W	W 1.8 d	1
Parking Brake	1.2 W	W 1.8 d	1
Headlights	1.2 W	W 1.8 d	1
Oil Pressure	1.2 W	W 1.8 d	1
Overdrive	1.2 W	W 1.8 d	1
Warning Flashers	1.2 W	W 1.8 d	1
El. Heated Window	1.2 W	W 1.8 d	1
Oxygen Sensor Reminder	1.2 W	W 1.8 d	1
Seat Belts	2 W	Ba 9 s	2
Bulb Failure	1.2 W	W 1.8 d	1

Specifications

FRONT END

Suspension is of the McPherson type with the shock absorber mounted in a strut in the coil spring.

Rack and pinion steering gear.

Safety steering column.

Front wheel alignment

The alignment specifications apply to an unloaded car but include fuel, coolant and spare wheel.

Toe-in $\frac{1}{8}'' = 0.12 \pm 0.06''$ (3.0 ± 1.5 mm), power steering

Camber +1 to + $1\frac{1}{2}^\circ$, difference not to exceed $\frac{1}{2}^\circ$ between left and right side

Caster Not adjustable

POWER TRANSMISSION

Hydraulically operated clutch of the single, dry-plate type.

Floor-shift operated manual transmission has four synchromesh forward gears, one reverse and electrically operated overdrive.

Optional automatic transmission.

Hypoid type final drive. Limited slip differential is optional.

Transmission

Type designation	M46	BW55
Reduction ratios		
1st gear	3.71:1	2.45:1
2nd gear	2.16:1	1.45:1
3rd gear	1.37:1	1.00:1
4th gear	1.00:1	—
Overdrive	0.79:1	—
Reverse	3.68:1	2.21:1

Rear axle	3.73:1	3.54:1
-----------	--------	--------

Speeds in mph (km/h) at 1,000 engine rpm

Transmission	M46
Rear axle ratio	3.73:1
1st gear	5.2 (8.3)
2nd gear	8.9 (14.3)
3rd gear	14.0 (22.5)
4th gear	19.1 (30.8)
Overdrive	23.9 (38.5)
Reverse	5.2 (8.4)

Recommended max. and min. speeds, mph (km/h)

1st gear	2nd gear	3rd gear	4th gear
-30 (-50)	15-53 (20-85)	22-85 (35-135)	28* - (45)

* 40 mph (65 km/h) with overdrive engaged.

Tool kit

Wheel nut and spark plug wrench.
 2 screwdrivers (1 Phillips, 1 standard).
 Tommy bar.
 2 open end wrenches.

Tire pressures

Tire	Recommended tire infl. pressure cold tires, psi (kpa)						Vehicle capacity weight
	Normal speed				>75 mph		
	1-3 pers.		Full load				
	Front	Rear	Front	Rear	Front	Rear	
185/70 R 14	27 (190)	27 (190)	28 (200)	32 (230)	28 (200)	32 (230)	770
Space saver spare	36 (250)	36 (250)	36 (250)	36 (250)	-	-	

See Consumer Information Booklet for complete tire pressure information.

Space saver spare tire max. speed 50 mph (80 km/h).

Volvo Service Manuals

Service Manuals for your Volvo are available for purchase. These are the same used by competent Volvo technicians. Each major system in the car is covered by an individual Manual. These are grouped into ten sections and placed into a binder system. (Note that Manuals and binders may be obtained separately or in preassembled sets.)

Major sections within the binder system include: 0-General Information; 1-Service and Maintenance Instruction; 2-Engine; 3-Electrical System; 4-Power Transmission; 5-Brakes; 6-Front End and Steering; 7-Frame Suspension and Wheels; 8-Body; 9-Accessories and Other Equipment.

A Service Manual Brochure and Order Form was placed in the car prior to delivery from the dealer to you. Complete ordering information is provided.

Please note that these manuals may be offered for sale by your Volvo dealer. Prices charged by the dealer can vary from those listed in the brochure (according to Federal law).

Additional copies of the Brochure and Order Form may be obtained from your Volvo dealer, or by mail directly from:

Volvo of America Corporation
Rockleigh Industrial Park
Rockleigh, New Jersey 07647

Attention: Volvo Service Literature

Note that the above pertains to vehicles sold in the U.S.A. only.



Volvo supports Voluntary Mechanic Certification by the N.I.A.S.E. Certified mechanics have demonstrated a high degree of competence in specific areas.

Besides passing exams each mechanic must also have worked in the field for two or more years before a certificate is issued.

These professional mechanics are fully able to analyze vehicle problems and perform the necessary service procedures to keep your Volvo at peak operating condition.

Note! The above pertains to USA only.

Air Conditioning	16	Doors and locks	24, 74	Horn	4
Air dam (front spoiler)	37, 66	Drain plug, engine	45	Ignition and steering wheel lock	8
Alternator, important note	59	rear axle	56	Instrument lights	9
Anti-freeze	58	transmission	54	Instruments and controls	4
Anti-rust treatment	70	Drive belts	46	Interior light	19, 62
Ash trays	18	Electrically heated rear window	14	Jack	68, 85
Automatic transmission, driving	32	Electrically operated windows	13	Keys	3
oil	55	Electrical system	83	Kick-down	33
Battery	40	Emergency towing (pulling)	34	Lambda-sond	48
Body and chassis	57	Engine number	80	License plate lights	62
Brake fluid	40, 56	Engine	41, 82	Light	9
Brakes	37	Engine oil	44	Limited slip differential	56
Break in period	28	Fan belts	46	Locks	24
Bulb failure warning light	7	Fault tracing	75	Long distance trips	74
Bulbs	59, 83	Federal Clean Air Act	39	Lubrication	57
Capacities	81	Fresh air lowers	17	Lumbar support	21
Chassis number	80	Front seats	21	Maintenance Service	39
Checking coolant	40, 58	Front wheel alignment	84	Odometer	6
oil	45	Frozen locks	74	Oil change, engine	44
Cigarette lighter	18	Fuel	26, 40	rear axle	56
Clock	18	Fuel gauge	6	transmission	54
Cold start	30	Fuel tank cap	26	Oil filter	45
Cold weather driving	74	Fuses	64	Oil pressure	7
Control lights	6	Gas filler cap	26	Overdrive	31
Coolant	58	Gasoline	26, 40	Paint touch-up	72
Coolant, drain	46	Gas station checks	40	Parking brake	8
Cooling system	46, 58, 74, 82	Gear shift positions	31	Parking lights	9
Cruise control	11	Hand brake	8	Polishing	70
Defroster	16	Hazard warning flasher	14	Power steering	56
Diagnosis	75	Headlight flasher	10	Power train	84
Dimensions and weights	81	Headlights	59		
Dipstick	44	replacement	60		
Door lock anti-freeze	74	Heating	16		
		Hood lock	26		

Index

Radios	20	Upholstery, cleaning	70
Rear axle oil	56	Vehicle Identification Number	80
Rear view mirrors	15	Ventilation outlets	17
Rear window demister	14	VIN, VIC	80
Rust protection	71	Vehicle Identification Number	80
Seat belts	22	Warning lights	7
Seats	21	Warranty	39
Service Diagnosis	75	Warranty inspection	27
Servicing	39	Washer fluid	12, 41, 74
Shift positions	31	Washer nozzles	12
Shop manuals, Volvo	86	Washing	70
Snow chains	66	Waxing	70
Snow tires	66	Weights	81
Spare wheel	25, 67	What causes rust	71
Spark plugs	49	Wheel alignment	84
Specifications	80	Wheel change	68
Speedometer	6	Wheels and tires	65
Starting engine	30	Windshield washers	12, 41, 74
Starting key	3	Windshield wipers	12, 71
Steering wheel lock	8	Wintertime driving	74
Tachometer	6		
Temperature gauge	6		
Tire pressure	65		
Tires	65		
Tire wear indicator	65		
Tools	85		
Touch-up	72		
Towing	34		
Trailer hauling	36		
Transmission oils	54		
Trunk	25		
Turn signals	10		
Type designations	80		

NOTES

NOTES

NOTES

NOTES

NOTES

NOTES

NOTES

NOTES

When filling gas always check:

Fuel: Octane rating 91 RON (unleaded) 87 (R+M)/2

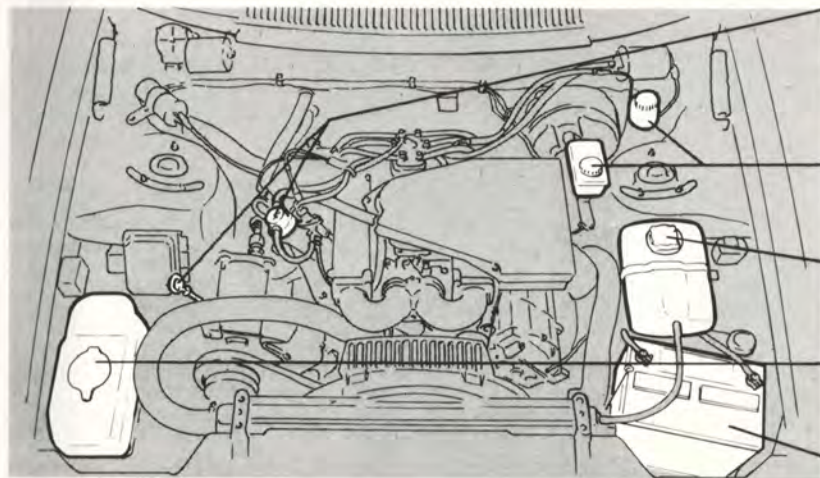

{ **Oil level** between dipstick marks. The distance between the marks represents approx. 2 US qts. = 2 liters

{ When necessary, add oil of the same type as already used.

{ Check without removing the cap that the **brake and clutch fluid** level is above the Min-mark. Brake and clutch fluid DOT 4.

{ **Coolant level** between the expansion tank marks. Mixture 50 % anti-freeze and 50 % water.

{ **Washer fluid** reservoir should be filled with water and solvent (wintertime: windshield washer anti-freeze).

{ **Electrolyte** level 1/4"-3/8" (5-10 mm) above plates. Fill distilled water only, never acid. Check level in conjunction with normal service or once a year.

In the Owner's Manual you will find instructions on how to replace bulbs on page 60
 ... how to replace fuses on page 64
 ... how to change a wheel on page 68

Tire pressures, cold tires, psi

Tire	Normal speed				>75 mph	
	1-3 pers.		Full load			
	Front	Rear	Front	Rear	Front	Rear
185/70R14	27	27	28	32	28	32
Space saver spare	36	36	36	36	-	-

VOLVO

AB VOLVO • GÖTEBORG, SWEDEN