

# **VOLVO**

**DL  
GL  
GLE  
TURBO**



**1984 OWNER'S MANUAL**

**U.S.A./CANADA**

**Notice to Owner:** Your Volvo is designed to meet all applicable safety and emission standards. Evidence of this can be verified from the certification labels attached to the door opening sheet metal and on the left wheel housing in the engine compartment. For further information regarding these regulations, please contact your local dealer.

**Owner Information**

Name .....

Address .....

City, State ..... Zip/Code .....

Tel. No. ....

**Car Information**

Vehicle Identification  
Number (VIN) .....

Starting (Ignition)/Door Key No. ....

Trunk/Glove Box Key No. ....

Delivery Date .....

**Notice:** All information, illustrations and specifications contained in this manual are based on the latest product information available at the time of publication. Volvo reserves the right to make model changes at any time, or to change specifications or design, without notice and without incurring obligation.

<b>DESCRIPTION</b>	<b>Page</b>		
General Information	2	Gear shift positions	37
Keys	3	Automatic transmission	38
Instruments and controls	4	Emergency towing	40
Instruments	6	Towing information	41
Warning lights	7	Trailer hauling	42
Ignition switch, turn signals	8	Automatic transmission, brake system	43
Lighting	9	Catalytic converter	44
Windshield wipers, washer nozzles	10		
Washer fluid reservoir	11	<b>MAINTENANCE SERVICE</b>	
Rear window demister, hazard warning flasher	12	Maintenance services	45
Parking brake, choke	13	Servicing	46
Clock, boost pressure gauge, ambient temperature gauge	14	Engine B23F,B21A,B21FT	48
Oil pressure gauge, voltmeter	15	Gas station checks	50
Cigarette lighter, ash trays	16	Engine oil	51
Electrically operated windows	17	Cooling system	53
Heating and ventilation	18	Servicing	54
Air conditioning	20	Carburetor	57
Radios, AM-FM-FM stereo/ tape players	21	Transmission oil	60
Front seats	22	Rear axle, power steering, brake fluid	62
Seat belts	24	Lubrication	63
Doors and locks	26	Coolant	64
Rear doors, trunk lid, vent windows	27	Alternator, jump starting	65
Long load storage, hood	28	Replacing bulbs	66
Rear/side view mirrors	29	Fuses	71
Interior light, sun roof, fuel tank cap	30	Wheels and tires	72
Rear seat, wagon	31	Wheel changing	74
Tailgate, wagon	32	Replacing wiper blades	76
Cargo compartment, wagon	33	Washing, cleaning	76
		Cleaning, anti-rust treatment	77
<b>STARTING AND DRIVING</b>		Paint touch-up	78
Service inspection	34	Long distance trips, cold weather	81
Break in period	34	Service diagnosis	82
Driving economy	35	Specifications	88
Starting the engine	36	Volvo service manuals	94
		<b>INDEX</b>	95

## General Information

---



55109

### Model versions of the basic Volvo Models DL, GL, GLE, Turbo

Volvo DL 2 door, 4 door, Wagon  
GL 4 door, Wagon  
GLE 4 door  
Turbo 2 door, 4 door, Wagon

Do not export your Volvo to another country before investigating that country's applicable safety and exhaust emission requirements. In some cases it may be impossible to comply with these requirements.





**Starting (ignition)/Steering wheel lock  
Front doors  
Tailgate (wagon)**

Write the key number codes on the inside of the front cover of this manual as well as your pocket diary.

These number codes are stamped on a separate tag supplied with the keys. This tag should be separated from the key ring and kept in a safe place.

The double-sided tape on the back of the tag can be used to secure it safely.

In the event the original keys are lost, duplicates may be ordered from your Volvo dealer.



**Trunk  
Glove box  
Floorlid (wagon)**



**Tag**

56720

# Instruments and Controls

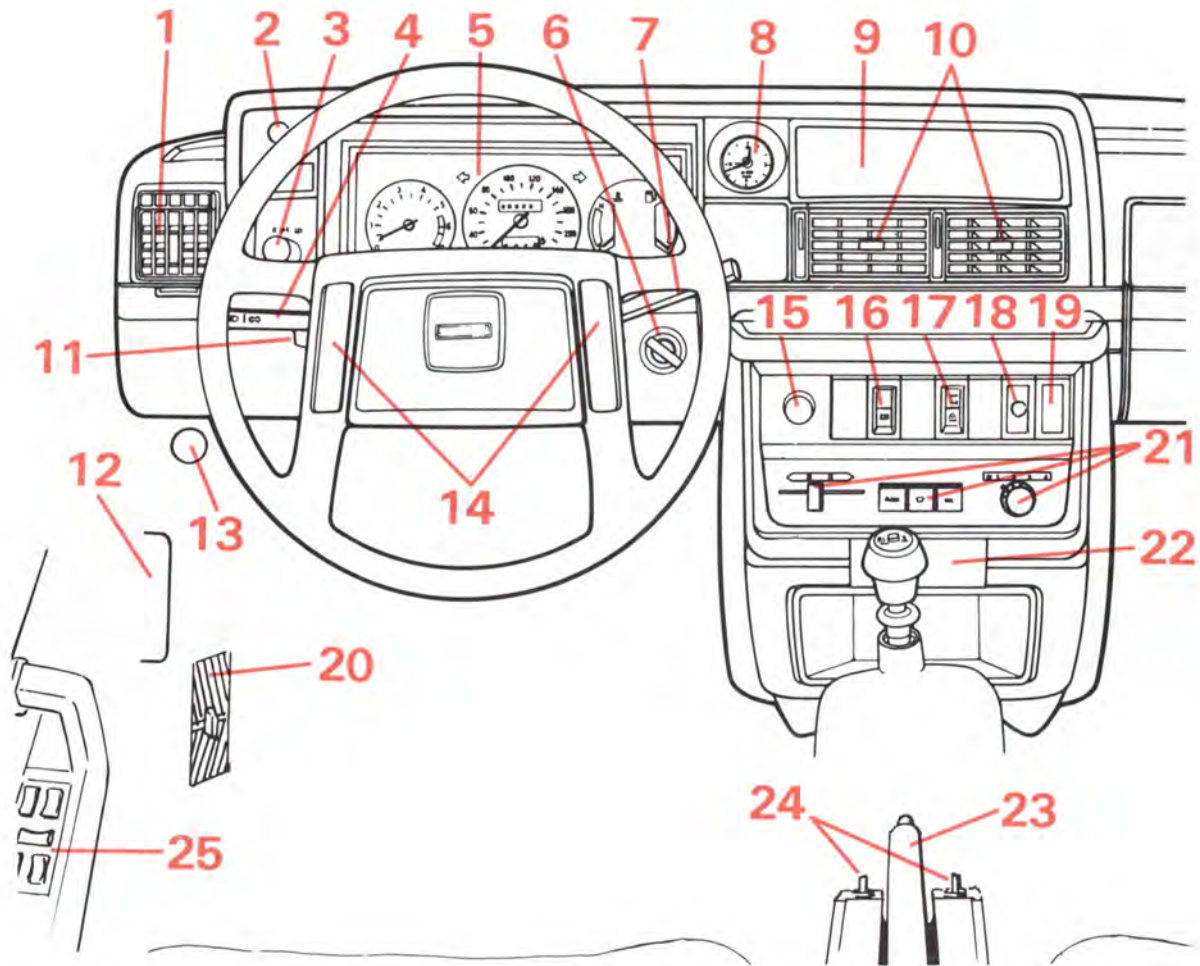

See page

1 Air louver	19
2 Instrument lights	9
3 Headlights, parking lights	9
4 Turn signals	8
5 Instruments	6
6 Ignition switch/steering wheel lock	8
7 Wiper/washer, tailgate window wiper/ washer (wagon)	10
8 Clock	14
9 Storage compartment (boost pressure gauge turbo engined cars only)	14
10 Air louver	19
11 Choke (only carburetor engine)	13
12 Fuse box	71
13 Hood release handle	28
14 Horn	—
15 Cigarette lighter	16
16 Rear window demister	12
17 Hazard warning flashers	12
18 Air conditioning	20
19 Seat belt reminder light	24
20 Fresh air louver	19
21 Heating and ventilation	18
22 Ash tray	16
23 Parking brake	13
24 Control for electrically operated side mirrors	29
25 Electrically operated windows	17

The pages in this section provide a detailed description of the vehicle's instruments and controls.

Note that vehicles may be differently equipped, depending on special legal requirements, etc.

# Instruments

## A Clock/Tachometer (certain models)

Reads thousands of engine rpm.

Black range for momentary use, during acceleration.

Engine should not be operated in red range.

## B Direction indicator (green)

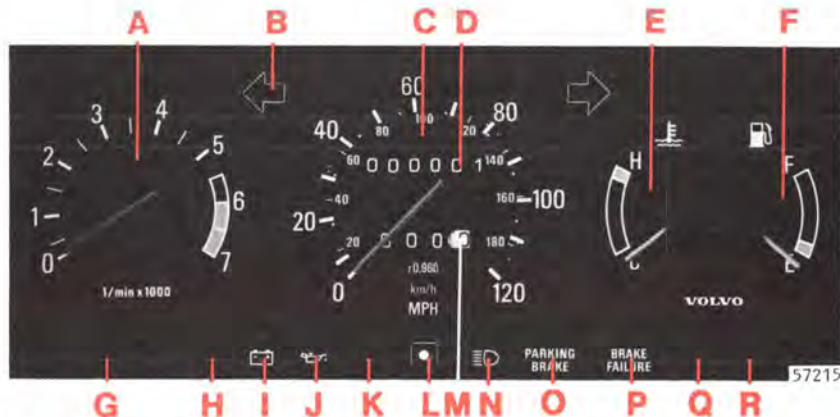

## C Speedometer

In kilometers and miles

## D Odometer

Total mileage reading.

## E Temperature gauge

The gauge pointer should remain inside the black range during normal operation.

If the pointer enters the red range, repeatedly, check coolant level and fan belt tension. (See sections titled "Cooling system and coolant")

Warning, allow engine to cool before adding fluid.

**Note:** Canadian model speedometers indicate kilometers only.

## F Fuel gauge

The fuel tank capacity is approx 60 liters = 15.8 US gals.

## G Reminder light, Lambda-sond™\* (oxygen sensor system) service

\*Lambda-sond TM is a trademark of Volvo of America Corporation.

## H Choke reminder light (yellow)

Lights when choke is used. (Certain Canadian models only.)

## Boost pressure warning light (red) (turbo engine models).

## I Alternator warning light (red)

## J Oil pressure warning light (red)

## K Overdrive indicator light (green)

Lights when overdrive is engaged.

## L Trip odometer reset knob

Push in to reset

## M Trip odometer

## N High beam indicator (blue)

## O Parking brake reminder light (red)

## P Brake failure warning light (red)

## Q Bulb failure warning light (yellow)

## R Overdrive OFF indicator light (green)

(Certain automatic transmission models only)



## The warning lights described on this page should never be on when driving

When the ignition key is turned on, and before the engine starts, all of the warning lights should be on to test the function of the bulbs. Should a light not go off after the engine has started, the system indicated should

be inspected. (However, the parking brake reminder light will not go off until the parking brake is fully released.)

### G Lambda—sond™ (oxygen sensor system) service reminder light (red)



56214/1

As required by the U.S. Environmental Protection Agency this light will come on at 30,000 mile (50,000 km) intervals. It is a reminder to have the oxygen sensor system serviced. The light will stay on until reset by servicing dealer.

### H Boost pressure warning light (turbo engine models)



56214/2

If the light goes on when driving, the boost pressure is too high. Drive the car to a repair shop for inspection, using care not to accelerate rapidly or drive at very high speed.

### I Alternator warning light (red)



56122/1

If the light comes on while the engine is running, check the tension of the alternator drive belt as soon as possible. (See section titled "Cooling system").

NOTE: This warning light is illuminated if the alternator is not charging. However, **alternator, parking brake, brake failure, Lambda—sond™ system service reminder and bulb failure will be illuminated at the same time** due to the design of the system.

### J Oil pressure warning light (red)



56122/2

If the light comes on during driving, the oil pressure is too low. Stop the engine immediately and check the engine oil level. See section titled "Engine Oil".

After hard driving, the light will come on occasionally when the engine is idling. This is normal, provided it goes off when the engine speed is increased.

### O Parking brake reminder light (red)



56122/3

This light will be on when the parking brake (hand brake) is applied. The parking brake lever is situated between the front seats.

### P Brake failure warning light (red)



56122/4

If the light comes on while driving and the brake pedal can be depressed further than normal, it is an indication that one of the brake circuits is not functioning. Proceed cautiously to a Volvo dealer for an inspection of the brake system.

### Q Bulb failure warning light (yellow)



56122/5

The light will come on if any of the following bulbs are defective:

- one of the lower beams
- one of the tail lights
- one of the brake lights (when the brake pedal is depressed).

See section on "Replacing Bulbs".

# Starting (ignition) switch, turn signals

## Starting (ignition) switch/steering wheel lock



- 0 Locked position:**  
remove the key to lock the steering wheel.



- I Intermediate position:**  
certain circuits (heater blower, cigarette lighter, accessories, etc.) on.



- II Drive position:**  
key position when engine is running.



- III Starting position:**  
release the key when engine starts. The key returns automatically to driving position.

53972

The steering wheel lock might be under tension when the car is parked. Turn the steering wheel slightly to free the ignition key.

A chime will sound if the starting key is in the ignition lock and the front door on the driver's side is open. The chime will also sound if the headlights or parking lights are on when the door is open.

The chime goes off when the front door is closed.



56178/1



56178/2

## Turn signals

### 1 Signal lever engaged for normal turns.

Defective turn signal bulb will cause turn signal indicator and remaining signal lights to flash more rapidly.

- 2 Lane change position.** In maneuvers such as lane changing, the driver can flash the turn signals by moving the turn signal lever to the first stop and holding it there. The lever will return to the neutral position when released.

### 3 High and low beam switching (headlights on).

Move the lever towards the steering wheel and release it.

### 3 Headlight flasher (headlights off).

Move the lever towards the steering wheel. The headlight high beam will be on until the lever is released.

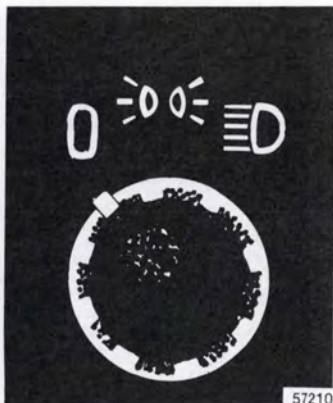

57210

## Headlights and position lights

0 All lights off

☾☽ Parking lights on

☾☽☾☾ Headlights and parking lights on

Switch from upper to lower beams, and vice versa, by moving the turn signal switch lever on the left side of the steering column towards the steering wheel. The lights can be used without switching on the starting (ignition) key.

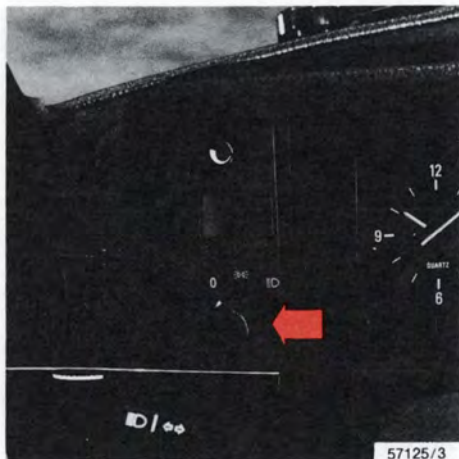

57125/3

A chime will sound if the headlights or parking lights are on and the front door on the driver's side is open. The chime will also sound if the starting (ignition) key is in the switch lock when the door is open.

The chime goes off when the front door is closed.

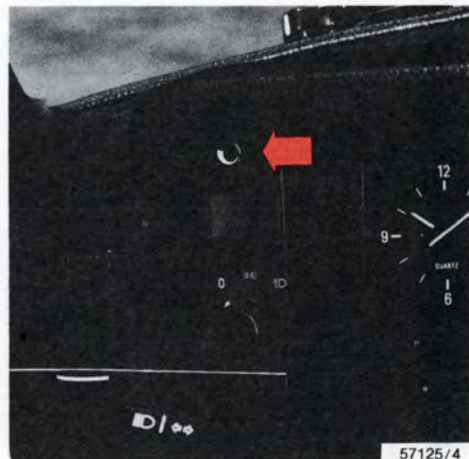

57125/4

## Instrument panel lamps rheostat

Clockwise — brighter

Counterclockwise — dimmer.



# Windshield wipers, tailgate window wiper, washer nozzles



## Wiper/washer

### 1 Intermittent wiper.

With switch in this position, the wipers will make a stroke every seventh second.

### 2 "Single stroke" position.

Switch returns automatically when released.

### 3 Wipers, low speed.

### 4 Wipers, high speed.

### 5 Windshield wiper/washer.

The wiper will make 2-3 complete stroking cycles after the lever is released.



## Tailgate window wiper/washer, wagon

Operated by the switch at the end of the windshield wiper/washer operating lever.

### 1 Tailgate wiper

### 2 Interval position (optional - certain models)

With the switch in this position, there is one stroking cycle approx. every fifteen seconds.

### 3 Tailgate washer

Depress the button to start the wiper/washer. The wiper will complete 2 - 3 stroking cycles after the button is released.

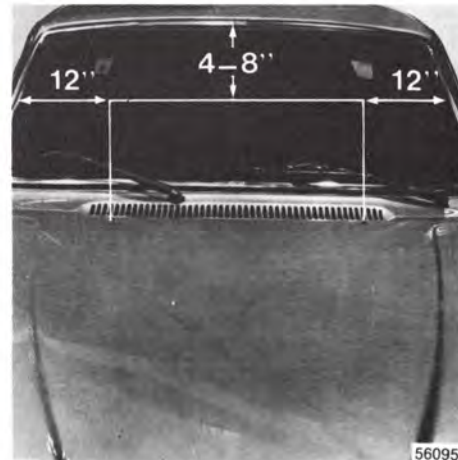

## Adjusting washer nozzles

The nozzles may be adjusted by inserting a needle into the metal nozzle and rotating nozzle to desired position.

4-8" = 10-20 cm.

12" = 30 cm.



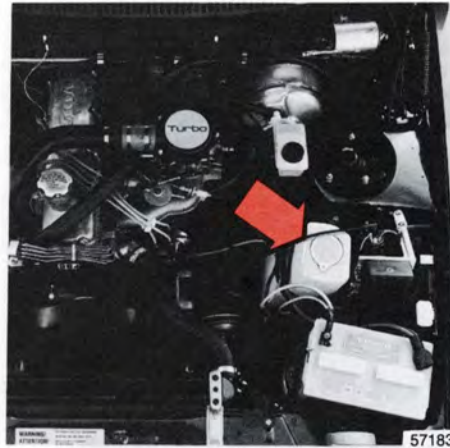

## Washer fluid reservoir

The washer fluid reservoir for the windshield and tailgate washer (wagon) is located in the engine compartment and holds approx. 1.6 US gals = 6.0 liters.

During wintertime, the reservoir should be filled with anti-freeze specified in section titled "Cold weather".

# Rear window demister, hazard warning flasher



## Rear window demister

To operate depress the switch. The indicator lamp in the switch will come on. The system will automatically be switched off after 10–15 minutes or when the starting (ignition) key is switched off. Do not place items against the inner surface of the rear window that may damage the printed circuit. Do not scrape the inner surface of the rear window glass with a hard object or use an abrasive window cleaner, otherwise damage to the printed circuit will occur.

## Hazard warning flasher

Four way flashing is used to indicate that the vehicle has become a traffic hazard (either during daylight or at night).

**NOTE:** Regulations regarding the use of the hazard warning flasher may vary from state to state.

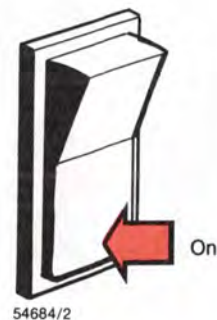
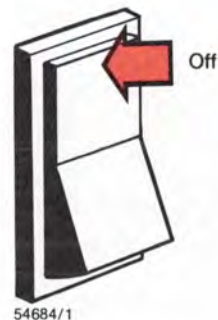



### Parking brake (hand brake)

The lever is situated between the front seats. The brake is applied to the rear wheels.

The reminder light PARKING BRAKE on the instrument panel comes on whenever the parking brake lever is not fully released and the ignition is on.

Always use the parking brake (hand brake) when parking, to maintain the best possible function.

For winter use, see section titled "Cold Weather".

In order to obtain the best possible performance of the parking brake, the brake linings should be broken in. (See section titled "Break in period".)

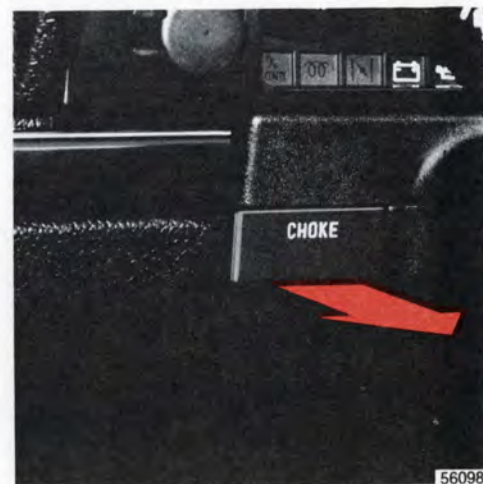

### Choke

#### (only in cars with carburetor engines for Canada)

Pull the choke out fully or  $\frac{2}{3}$  before starting a cold engine.

Pulling the choke out less than one inch (approx.) regulates idling without affecting choke.

Choke light on the instrument panel goes on when the choke is pulled out.

**Use the choke as briefly as possible**

Also see section titled "Starting the engine".

## Clock, boost pressure gauge, ambient temperature gauge

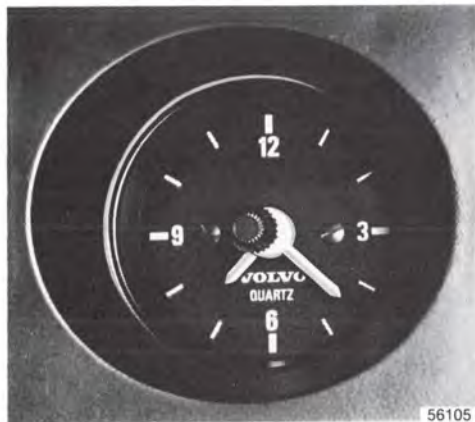

### Quartz crystal clock

To reset the hands, push in the reset knob and turn.

**Note:** A slight ticking sound emitted by the clock is considered normal.



### Boost pressure gauge

(turbo engine cars only)

The boost pressure gauge is divided into three sections.

**Black section:** The engine acts as a normally aspirated engine. This is the economical range.

**Yellow section.** The turbo is engaged.

**Red section.** The pressure in the intake manifold is too high. Drive the car carefully to a Volvo dealer for inspection.

The warning light for boost pressure goes on if the gauge pointer moves into the red section.



### Ambient temp. gauge (Canada)

(accessory U.S.A. models)

Electronic gauge which shows ambient temperature just above the road surface. Warns you of icy road conditions.





## Oil pressure gauge

(certain models)

The oil pressure gauge indicates the pressure of the oil in the lubricating system of the engine. The pressure is dependent on the speed of the engine, the oil temperature and the viscosity of the oil.

**The gauge pointer must not go down to the red field while driving.**

However, it may happen while idling with a hot engine that the pointer does go into the red field. This is not unusual providing the pointer rises to the normal driving range again when you increase the engine speed.

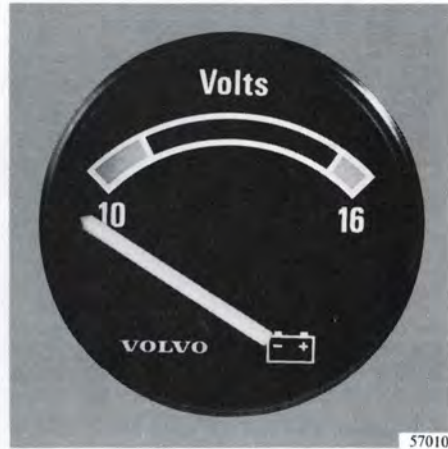

## Voltmeter

(certain models)

The voltmeter indicates the voltage in the electrical system and thereby also the state of the battery. While the car is being driven the pointer should be within the black field.

Should the pointer point to the upper or lower red field when driving, this may indicate some fault in the electrical system.

## Cigarette lighter, ash tray



Lighter

Ash tray

### Cigarette lighter

To operate, depress the knob fully. When the knob automatically releases, the cigarette lighter is ready for use.

The starting (ignition) switch must be ON for the cigarette lighter to function.

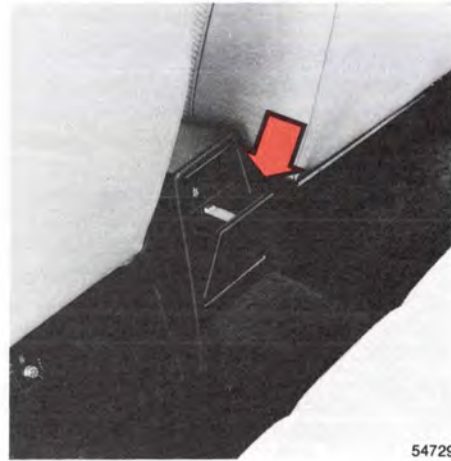

Rear seat ash tray

### Ash trays

To remove the ash trays depress the center spring and remove.

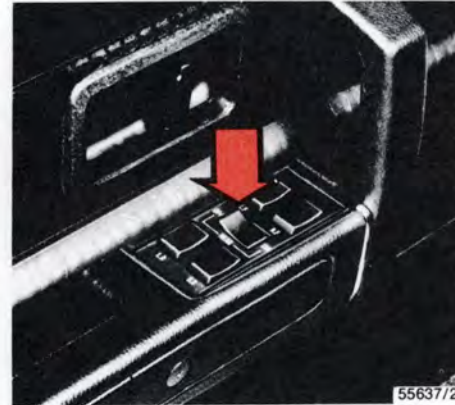
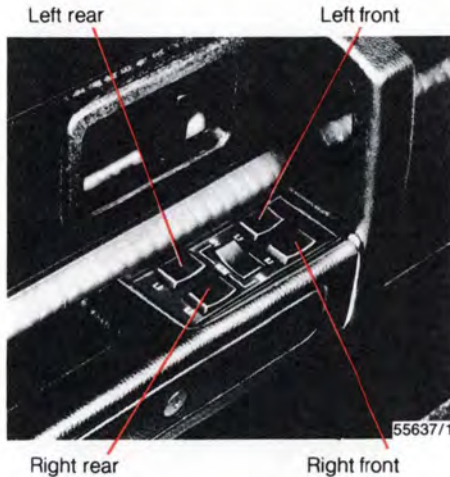

## Electrically operated windows (standard on certain models)

The electrically operated windows are controlled by switches set in the door arm rests. All the windows can be controlled from the driver's arm rest as shown in the above illustration.

The starting (ignition) switch must be ON for the electrically operated windows to function. The window is lowered if the rear part of the switch is pressed and raised if the front part of the switch is pressed.

## Cut-out switch for rear door electrically operated windows

If the car is equipped with rear door power windows, this function can be disabled by a switch located on the driver's door armrest.

This switch is positioned 90° in relation to the other switches.

ON — The rear door windows can be raised or lowered with the respective door switch as well as the switch on the driver's door.

OFF — The rear door windows **cannot** be raised or lowered with the respective door switch but instead **only** with the corresponding switch on the driver's door.

# Heating and ventilation

## Heating system

### 1 TEMP

Left = cool

Right = warm

### 2 FLOOR

Out = no air to floor

In = full flow of air to front and rear floor

### 3 DEF (defrost)

Out = low volume air flow to defroster

In = full flow

### 4 REC (recirculation)

To be used only for cars equipped with air conditioning.

Do not use for heating.

Out = full flow of outside air

In = air is recirculated for faster cooling

### 5 FAN (Blower motor)

The fan has 4 speeds and is shut completely off when the knob is turned to the left.

### 6 Air louvers (dash)

The air flow through the louvers is decreased when the FLOOR (2) and/or DEF (3) controls are depressed.

### 7 Fresh air louvers (floor)

Lever placed forward = louver opens

Lever placed rearward = louver closes

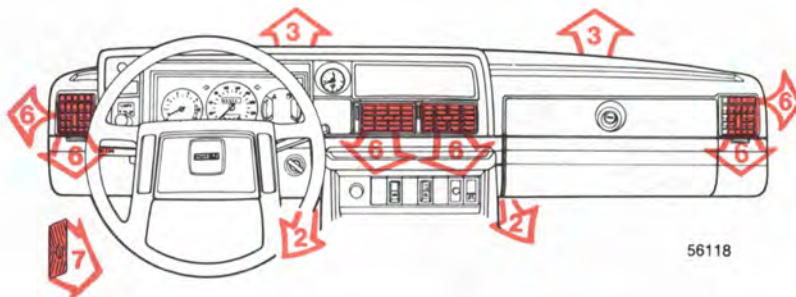

56118



56112/3



## How to . . .

### . . . obtain max. heat

- 1 TEMP → WARM
- 2 FLOOR depressed
- 5 FAN → 3 (or 4)
- 6 All dash louvers halfway open and floor air louver closed.

### . . . remove condensation

- 1 TEMP → WARM
- 3 DEF depressed
- 5 FAN → 3 (or 4)
- 6 All louvers closed as well as the floor fresh air louver.

Always keep front external inlet grille (in front of the windshield) clear of obstructions (snow, ice, etc.).

### Maximum defroster action

For maximum defroster capacity at very low ambient temperatures, use the recirculation control (button depressed).

If not using air conditioning, the recirculation feature should **not** be used in humid climates and temperatures above +23°F (-5°C).

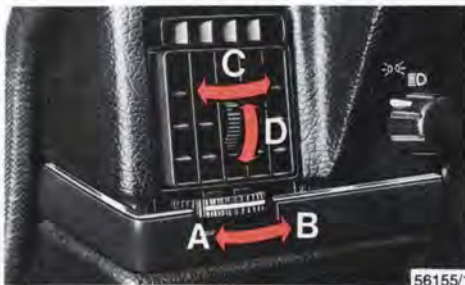

### Air louvers (dash)

- A Closed
- B Open
- C Directing air flow horizontally
- D Directing air flow vertically

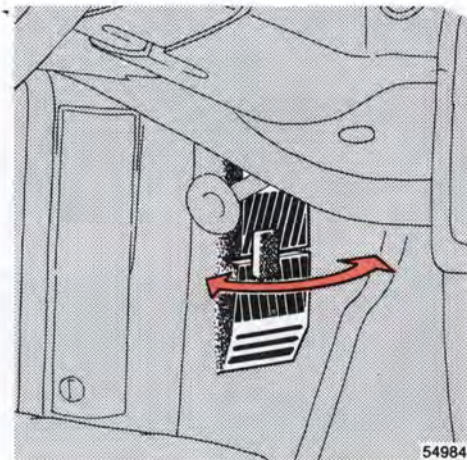

### Fresh air louver (floor)

There is a floor directed fresh air louver on the driver and passenger sides of the vehicle (driver's side only on some models). Airflow is controlled by the lever at the center of the louver.

Lever placed forward = louver opens  
Lever placed rearward = louver closes

Maximum airflow is obtained with louver fully open and the fan (blower motor) shut completely off. (The fan forces the air through the dash louvers.)

# Air conditioning



## Air conditioning (standard on certain models)

How to use the air conditioner:

### 1 FAN

Position 4 for rapid cooling.

### 2 AIR COND

Start the air conditioning compressor by turning the control knob clockwise toward MAX.

For rapid cooling, position the knob into the orange range beyond MAX. After desired temperature is reached re-position the control knob into the blue range.

**At cruising speeds, the knob should be kept within the blue range.** If it remains in the orange range, icing may occur resulting in decreased cooling capacity.

### 3 REC (Recirculation)

Push in for rapid cooling and during high humidity conditions.

### 4 TEMP

When using the air conditioner for cooling, the TEMP control should be set to COOL position, fully left. Use the AIR COND control to regulate the temperature.

To obtain rapid cooling, all windows must be closed and buttons FLOOR and DEF out. Close the floor fresh air louvers.

Cool air will then be discharged through the four dash outlets which should be fully open.

**NOTE:** For rapid removal of condensation from inside glass surfaces, the air conditioner can be switched on even when not required for interior cooling. The air conditioner will dehumidify the air inside the vehicle.

Have your Volvo dealer check the system for correct operation yearly. The air conditioning system should be operated periodically during the winter season.

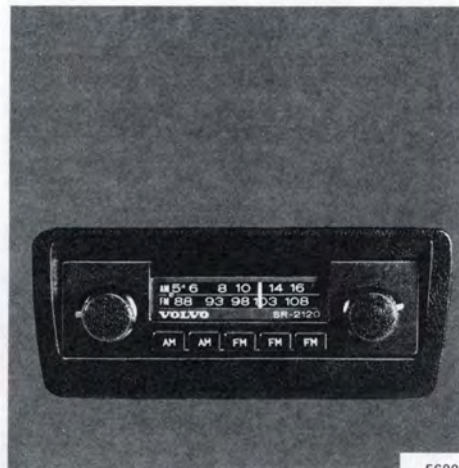

## Operating instructions

This optional equipment is available from Volvo Accessories in several different models, each with its own special features. Operating instructions are contained in the manuals associated with each model.

These manuals are placed in the cars when the equipment is installed by the Dealer.

Your Volvo Dealer will be able to assist you with any questions regarding the operation of this equipment.

## Radio antenna mast

**NOTE:** Always lower the antenna mast when entering automatic car wash.



# Front seats

## Driver seat height

There are two levers, each with three positions, for adjusting the height of the seat (front and/or back of cushion).

This allows adjustment of the seat cushion angle for added comfort.

After adjusting the seat check that it is securely latched.

**NOTE! Do not attempt to adjust seat height while seated.**

## Electrically heated seats (standard on certain models)

The driver's seat is electrically heated and is thermostatically controlled. Automatic engagement begins at 50°F (+10°C) and ends at 86°F (+30°C).

## Horizontal seat adjustment

Pull control upward, then slide seat forward or rearward to desired position.

**Make sure that the seat is properly secured when you release the control.**

**Note:** For your safety, never adjust seat while driving.

## Seat back release, 2-door models

Press the button and fold seat back forward to allow passengers access to/from the rear seats.

## Lumbar support adjustment

SOFT

FIRM

54988

## Seat back inclination

Rotate control clockwise to tilt seat back rearward.

Rotate counterclockwise to tilt seat back forward.

**Note that body weight must be shifted to allow seat back to move forward or rearward.**

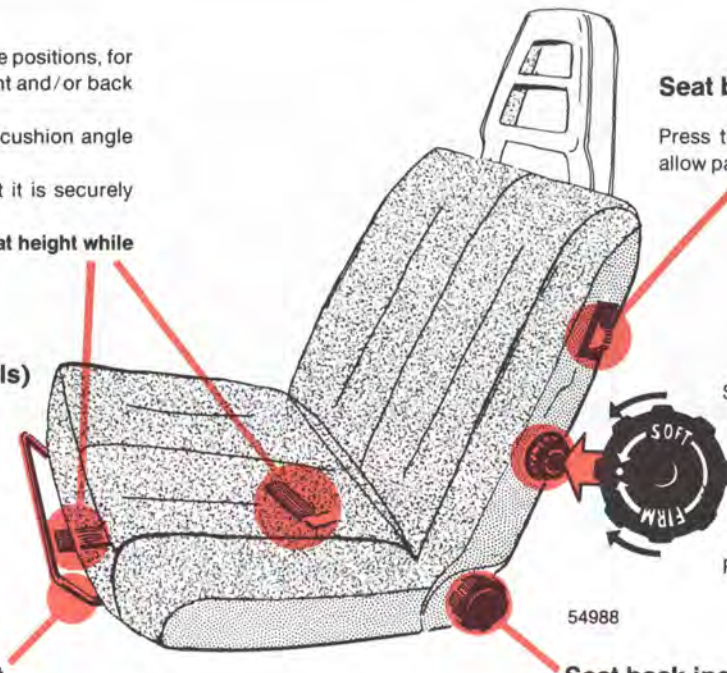





### Passenger seat height

The front passenger seat is retained by four brackets, each with three positions. The positions are the same as the driver's seat. However, this adjustment must be accomplished manually using appropriate hand tools.

### Child safety

Volvo recommends the proper use of restraint systems for all occupants including children. Remember that regardless of age and size, a child should always be properly restrained in a car.

Holding a child in your arms is NOT a substitute for a child restraint system. In an accident, a child held in a person's arms can be crushed between the vehicle's interior and an unrestrained person. The child could also be injured by striking the interior, or by being ejected from the vehicle during a sudden maneuver or impact. The same can also happen if the infant or child rides on the seat unrestrained. Other occupants should also be properly restrained to help reduce the chance of injuring or increasing the injury of a child.

In many states and provinces there is legislation governing how and where children should be carried in a car. Find out the regulations existing in your state or province.

A child restraint system can help protect a child in a vehicle. Here's what to look for when selecting a child restraint system:

- It should have a label certifying that it meets applicable Federal Motor Vehicle Safety Standards (FMVSS 213-80) — or in Canada, CMVSS 213.
- Make sure the child restraint system is appropriate for the child's height, weight and development—the label required by the standard or regulation, or instructions for infant restraints, typically provide this information.
- **In using any child restraint system, we urge you to carefully look over the instructions that are provided with the restraint. Be sure you understand them and can use the device properly and safely in this vehicle.**

When a child has outgrown the child safety seat (approximately 4-5 years, depending on size) you should use the rear seat with the standard seat belt fastened. The best way to protect the child here is to place the child on a cushion so that the seat shoulder belt is as far down on the hips as possible.

A safety cushion for this purpose can be obtained from your Volvo dealer. (Approval pending in Canada).

# Seat belts



56112/5



54738



57208

Release buttons, front seats

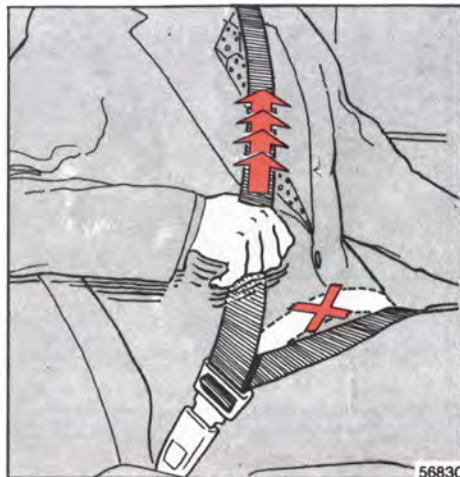

56830

## Seat belts, retractable

### Fasten the seat belts whenever you drive or ride.

Two lights will be illuminated for 4–8 seconds after the starting (ignition) key is turned to driving position. One light is located in the instrument cluster and one in the console between the front seats.

A chime will sound at the same time if the driver has not fastened his seat belt. The front and rear outboard seats are provided with self-retracting inertia belts.

### To buckle:

Pull the belt out from the retractor far enough to insert the latch plate into the receptacle (buckle for rear seats), until a distinct snapping sound is heard. The belt should not be twisted or turned.

To unfasten, depress red pushbutton in receptacle (buckle) and let the belts rewind into their retractors.

**Note:** The lap belt should sit low and tight under abdomen.

The seat belt retractors are normally “unlocked”. The retractors will lock up as follows:

- if belt is pulled out rapidly
- during braking and acceleration
- if the vehicle is leaning excessively
- when driving in turns

Check seat belt mechanism function as follows:

1. Attach the seat belt. Pull rapidly on the strap.
2. **CAUTION: Check other traffic before accomplishing this check.**

Brake firmly from approximately 30 mph (50 km/h) or turn in a tight circle while pulling on the belt.

In all the above checks you should not be able to pull the belt out.

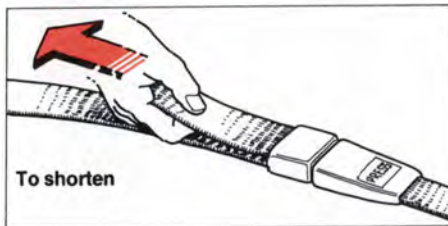
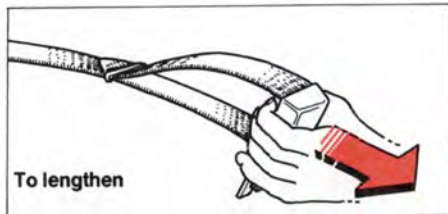

56405

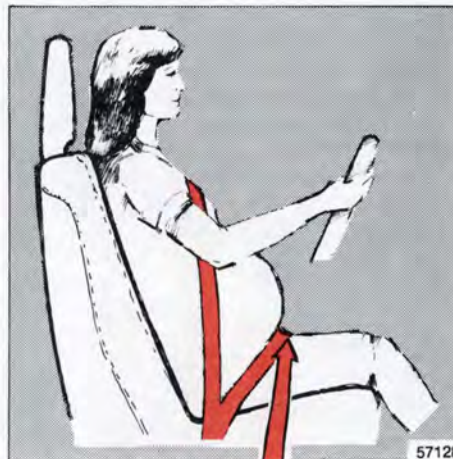

57128

## Seat belts, manually adjustable

The center rear seat belt is manually adjustable. It should always be adjusted to the correct length.

**To lengthen**, angle the buckle as shown in the upper illustration and pull the belt through.

**To shorten**, pull the upper part of the double webbing until snug.

## Pregnant women

Pregnant women should always wear seat belts. Remember that the belt should always be positioned in such a way as to avoid any possible pressure on the abdomen. The lap belt should be located low, as shown in the above illustration.

## WARNING!

Never use a seat belt for more than one occupant.

Never wear the shoulder portion of the belt under the arm or otherwise out of position. Such use could in event of accident cause injury.

Volvo recommends that all occupants wear and fasten their seat belts.

## Maintenance

Check periodically that the anchor bolts are secure and that the belts are in good condition.

Use water and a mild detergent for cleaning.

**As the seat belts lose much of their strength when exposed to violent stretching, they should be replaced after collision, even though they may appear to be undamaged.**

Never modify or repair the belt on your own, but have this done by an authorized Volvo dealer.



## Doors and locks



### Unlocking front doors

Both front doors can be unlocked by using the starting (ignition) key. Turning the key  $\frac{1}{4}$  turn counter-clockwise (right door: clockwise) lifts the lock buttons on the window ledge and the door can be opened by pulling the handle.

To open a door from inside, the lock button must first be pulled up.

In wintertime the door locks should be "lubricated" with a suitable agent to prevent freezing. If the lock is frozen, be careful not to break the key in the lock. Thaw the ice by heating the lock or the key. Use an electric heater with blower to prevent paint damage when thawing lock.

### Locking doors

All doors can be locked by depressing the lock buttons. To lock, depress the lock button and shut the door.

#### **Do not leave the key inside the car!**

Both front doors can be locked by using the key. Turning the key  $\frac{1}{4}$  turn clockwise (left door) or counter clockwise (right door) locks the doors.

**The lock buttons should not be in the down position during driving. In case of an accident, this may hinder rapid access to the occupants of the vehicle.**

### Central lock

Certain models are equipped with a central lock system. This means the lock on the driver's door automatically controls the locks on the other doors (including the tailgate on the wagon model). If the driver's door is locked or unlocked from the outside using the key, the other doors will automatically be locked or unlocked.

To lock/unlock the car by using the lock button on the inside of the driver's door, push/pull gently to lock/unlock only the driver's door or slightly harder to lock/unlock all the doors. Check the action of the buttons on the other doors to ensure their correct function (lock/unlock).



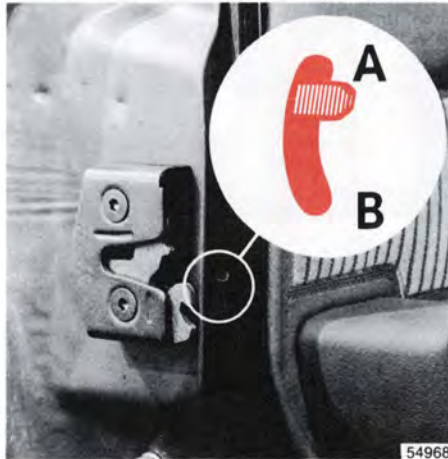

### Child safety locks (all except 2 door models)

The buttons are located on the rear door jambs.

#### A Normal lock function.

**B The door cannot be opened from the inside.**

**Remember, in the event of an accident, the rear seat passengers cannot open the doors from the inside with the buttons in position B.**

Wagon model contains child safety lock on tailgate. The lock differs from that shown above. See section titled "Wagon, tailgate".



### Trunk lid (2 and 4 door models)

**The lid can only be opened by using the key.**

Open by turning the key  $\frac{1}{4}$  turn, as shown. The spare wheel jack and tool kit are stowed in the left side of the trunk.

### Electrically operated trunk lock (certain models)

The trunk lock can be released electrically by actuating a pushbutton switch in the glove box.

- Depress switch to release lock
- Closing trunk lid automatically resets the lock

Lid may be operated manually using key.

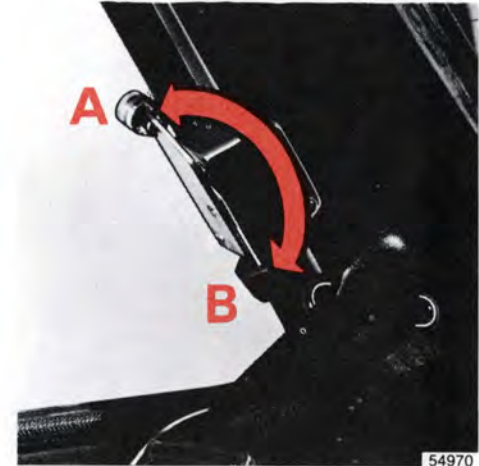

### Rear vent windows, 2-door models

**A Open**

**B Closed**

## Trunk light, long load storage, hood

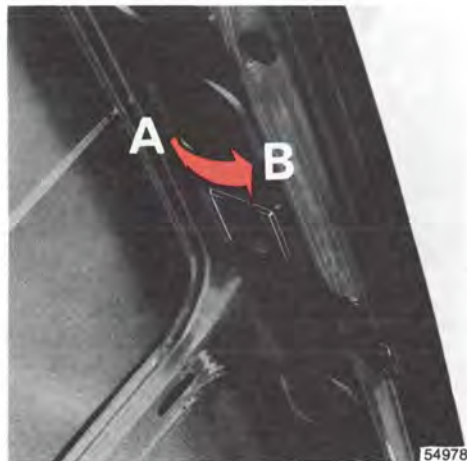

### Trunk light, 4 door model

- A Light always off.
- B Light on when trunk lid is opened.

### Long load storage, 2/4 door model

A flap in the rear seat makes it possible to carry "long loads" such as skis, etc. An optional, specially designed, storage bag should also be used to avoid soiling or tearing the upholstery. Please note that the flap in the rear seat is only intended for light loads such as skis, wood, etc.

Max. length of load 6½ ft = 2 m.

Max. weight of load 33 lbs = 15 kg



### WARNING!

When braking rapidly the load could be displaced and cause injury to occupants. Sharp edges on the load should be covered for protection. It is essential that the "load" be secured safely. Use belts locked around the folded down armrest (see illustration).

### WARNING!

Take care when loading/unloading the vehicle. Always turn off the engine and apply the parking brake. Place Automatic transmission gearshift selector in position P (Park). This will prevent accidental movement of the gear shift selector to position D (Drive).



### To open the hood

Pull the release handle (located under the left side of the dash).

Lift the hood slightly, insert a hand under the center line of the hood and depress the safety catch handle. Open the hood.

**Check that the hood locks properly when closing.**



53450

## Rear view mirror

- D Normal position
- N Night position, reduces glare from following headlights

### WARNING!

Packages on the rear window shelf can obscure vision and may become dangerous projectiles in event of sudden stop or accident.



55581

## Side view mirrors (manually operated)

- A Adjustment sideways
- B Adjustment up/down

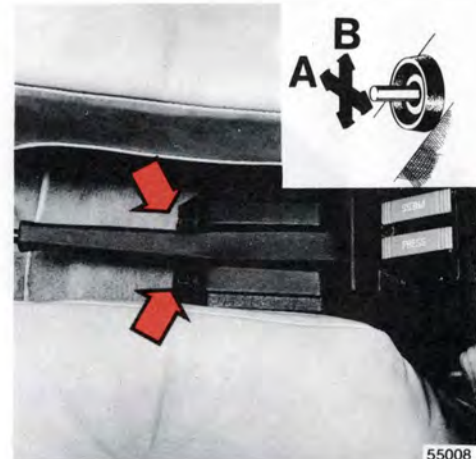

55008

## Electrically operated side view mirrors (certain models)

The control switches are located in front of the parking brake housing.

- A Adjustment sideways
- B Adjustment up/down

Avoid using ice scrapers made of metal as they can easily scratch the mirror surface.

**The mirrors should always be adjusted before driving.**



## Interior light, sunroof, fuel tank cap



### Interior light

- 1 Light always on.
- 2 Light always off.
- 3 Light is on when either of the front or rear doors are opened.

The wagon model has a slightly different kind of interior lamp housing.

On some models a time delay device illuminates the interior light for approx. 15 seconds after closing the driver's door. This facilitates finding starting (ignition) switch, etc., during darkness.



### Sunroof (certain models)

The sunroof is operated by a handle located between the sun visors. Unfold the handle and turn it counter-clockwise to open, clockwise to close.

**For safety reasons, the handle should always be folded when driving.**



### Filling fuel

The fuel tank cap is located behind the door on the right rear fender. Open slowly during hot weather conditions.

When filling, position the cap in the special bracket on the door.

After filling the tank, install the cap and turn until a "click" is heard.

An optional locking cap is also available. Refer to section titled "Fuel system" for additional information.



The following pages describe the rear seat, tailgate and cargo compartment of the wagon model.



### Folding rear seat

Depress either lever located at the front bottom edge of the rear seat cushion (right or left side). Tilt the seat towards the front seat.

Note:

It may be necessary to move front seats forward or raise the seat backs slightly to allow rear seat to fold down.

Pull the handle on the rear side of the seat back sideways, and fold the seat back forward and down so that it lies flat. The rear seat back and cushion are held automatically in their respective positions.

#### **CAUTION:**

**When returning the rear seat to its normal position, make sure the latches are securely locked and the seat belts are in a position where they are easily accessible for use.**

## Wagon, tailgate



### To open from the outside

Depress the release button located under the tailgate handle.

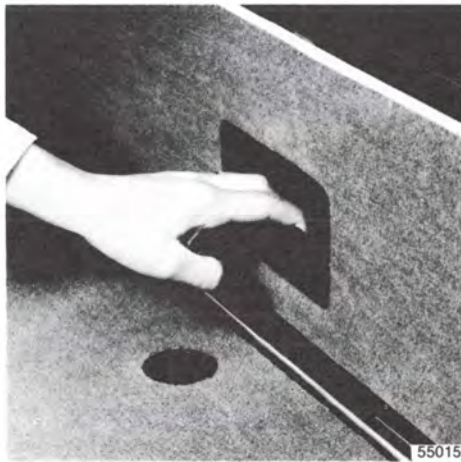

### To open from the inside

Pull out the T-handle located at the bottom of the tailgate.

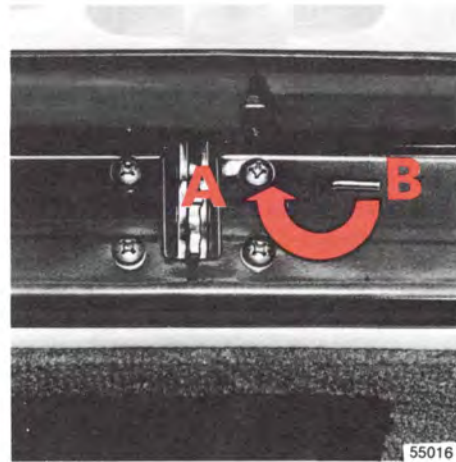

### Safety catch

A The lid cannot be opened from the inside.  
B The lock functions normally.

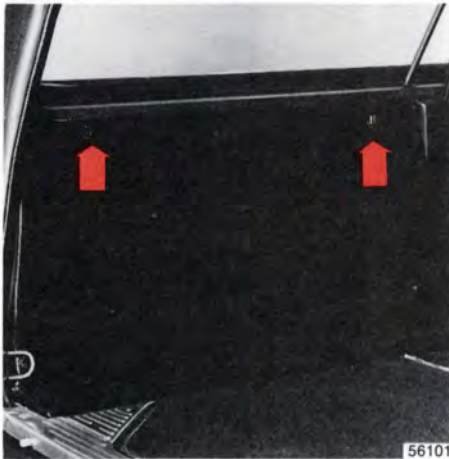

### Spare wheel, jack

The spare wheel and jack are stored under the hatch to the left in the cargo compartment. Loosen the two clips  $\frac{1}{4}$  turn and lift off the hatch.

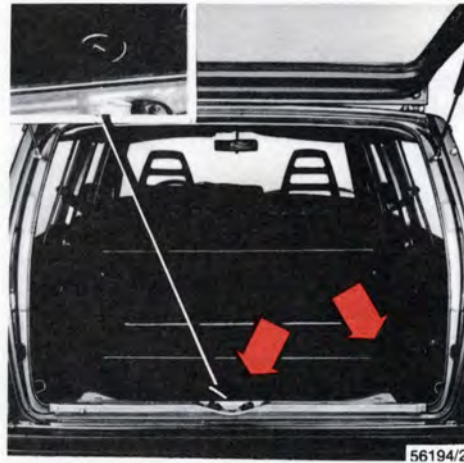

### Concealed storage space

There are two concealed storage areas under the cargo compartment floor.

#### Locking floor lid

The larger lid is lockable and should be used when increased security for stored articles is desirable.



### Eyelets

Six eyelets are provided in the cargo compartment for anchoring cargo.

Four eyelets are shown in the illustration. The remaining two are accessible when the seat back is folded forward.

**Note:** The eyelets are not to be used as occupant restraints.

**CAUTION:** Luggage or other cargo should not be stowed higher than the seat backs. All items should be secured in place.



# STARTING AND DRIVING

## A new car should be broken in!

### Manual transmission

During the break in period do not exceed the following speeds\*:

#### First 600 miles (1,000 km)

1st gear	20 mph	(30 km/h)
2nd gear	30 mph	(50 km/h)
3rd gear	50 mph	(80 km/h)
4th gear	70 mph	(110 km/h) <sup>1)</sup>

<sup>1)</sup> 80 mph (130 km/h) with overdrive engaged. Do not use overdrive below 40 mph (65 km/h).

#### 600 — 1,200 miles (1,000—2,000 km)

1st gear	25 mph	(40 km/h)
2nd gear	40 mph	(65 km/h)
3rd gear	60 mph	(100 km/h)
4th gear	80 mph	(130 km/h) <sup>2)</sup>

Avoid driving at low speed in high gear.

<sup>2)</sup> 90 mph (150 km/h) with overdrive engaged.

### Automatic transmission

Refrain from using "kick-down" when driving a car equipped with an automatic transmission during the first 1,200 miles (2,000 km).

\* These are the maximum speeds recommended by the factory. Note that legislation in different countries and states can stipulate other maximum speeds than those given here.

### Breaking in parking brakes

To obtain best parking brake performance, the brake linings should be broken in.

Stop 5-7 times from 30 mph (50 km/h), transmission in neutral, applying the parking brake with the release button pressed in during the stop. The force must not lock the rear wheels. If this happens, release the brake enough to let the wheels rotate. Drive a mile between each stop to cool the brakes. Check for proper parking brake operation.

#### NOTE:

The brake lights are not illuminated when applying the parking brake. To warn traffic from behind it is therefore advisable to depress the brake pedal slightly to illuminate the stop lights.

### Service Inspection

To ensure proper operation the car should be taken to a Volvo dealer between the first 600—1,200 miles (1,000—2,000 km) for a service inspection. The oil in the engine, manual transmission and rear axle will then be changed. This is very important since the oil rapidly collects impurities during the break in period.

## Economical driving does not necessarily mean driving slow

Better driving economy may be obtained by thinking ahead, avoiding rapid starts and stops and adjusting the speed of your vehicle to immediate traffic conditions. Observe the following rules:

- Bring the engine to normal operating temperature as soon as possible by driving under light load. A cold engine uses more fuel and is subject to increased wear.
- When possible avoid using the car for driving short distances. This does not allow the engine to reach normal operating temperature.
- Drive carefully and avoid rapid acceleration and hard braking.
- Do not exceed speed limit.
- Avoid carrying unnecessary items (extra load) in the car.
- Check tire pressure regularly — cold tires.
- Remove snow tires when threat of snow or ice has ended.
- Note that roof racks, ski racks, etc., increase air resistance and thereby fuel consumption.

Utilize the transmission to improve fuel economy. Use correct gear!

- From first to second gear at approx. 10 mph (20 km/h)  
From second to third gear at approx. 20 mph (35 km/h)  
From third to fourth gear at approx. 30 mph (50 km/h)
- If vehicle is equipped with overdrive, use it at every opportunity (at speeds in excess of 35 mph = 55 km/h)
- Avoid using automatic transmission kick-down feature unless necessary.

Other factors which decrease gas mileage are:

- Worn or dirty spark plugs
- Incorrect spark plug gap
- Dirty air filter
- Incorrect valve clearance
- Incorrect idle speed
- Dirty engine oil and clogged oil filter
- Dragging brakes
- Incorrect front end alignment
- Low tire pressure

The above mentioned items and others are checked at the standard 7,500 Mile (12,500 km) Maintenance Service intervals.

# Starting the engine

## To start the engine;

### Injection engine (B21F Turbo, B23F)

- 1 Enter the car and fasten the seat belt.
- 2 Apply the parking brake, if not already set.
- 3 Place the gear selector lever in neutral (position N or P, automatic transmission).
- 4 Depress the clutch pedal (manual transmission).
- 5 Without touching the accelerator pedal turn the ignition key to starting position. Release the key as soon as the engine starts

If the engine does not start at once, depress the accelerator pedal halfway and keep it there until the engine starts.

Avoid repeated short attempts to start (fuel is injected every time the starter is engaged when engine is cold).

Allow the starter to operate for a longer time (but not more than 15-20 seconds).

**Do not race a cold engine immediately after starting.**

### Carburetor engine (B21A, Canada)

- 1 Enter the car and fasten the seat belt.
- 2 Apply the parking brake, if not already set.
- 3 Place the gear selector lever in neutral (position N or P, automatic transmission).
- 4 Depress the clutch pedal (manual transmission).
- 4 Cold engine  
**Temperature below 50° F (+ 10° C):**  
Pull out the choke fully, do not touch the gas pedal.  
**Temperature above 50° F (+ 10° C):**  
Pull out the choke  $\frac{3}{4}$  of its travel, do not touch the gas pedal.  
**Hot engine:**  
Depress gas pedal half-way.  
If the engine does not start immediately when hot, depress the gas pedal to the floor and keep it there until the engine starts.
- 5 Turn the ignition key to start position. Release the key when the engine has started.
- 6 Push in the choke until best idling is obtained. Push it in more and more as the engine becomes warmer.  
The choke should be pushed fully in when the engine is thoroughly warm.

**Do not race a cold engine immediately after starting.**

## Engine warm-up — initial driving procedure

Experience shows that engines in vehicles driven short distances are subject to abnormally rapid wear because the engine never reaches normal operating temperature.

It is therefore beneficial to reach normal operating temperature as soon as possible. This is achieved by driving with a light load as soon as possible.

## Warning

Always open the garage doors fully before starting the engine inside the garage to ensure adequate ventilation. The exhaust gases contain carbon monoxide, which is invisible and odorless but very poisonous.

## TURBO CAUTION

**Especially important for cars with turbo engines:**

Do not race the engine immediately after starting. When cold, oil flows less rapidly and will not reach all necessary parts immediately.

Before switching off:

**Always** let the engine speed drop to **idle** before switching off. After a hard drive let the engine idle for a few minutes before switching off. If the turbo is rotating at high speeds and the engine is switched off there is a great risk of heat damage or seizing due to lack of lubrication.





56122/6

The overdrive light on the instrument panel goes on when the overdrive is engaged.

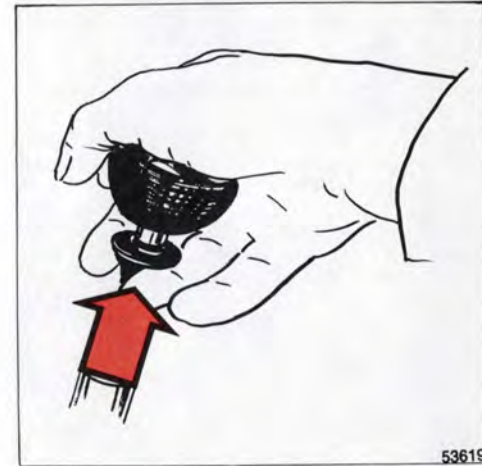

## 4-speed manual transmission

Depress the clutch fully when changing gears.

### Overdrive

Shift to overdrive at speeds in excess of 35 mph (55 km/h) and disengage it when speed drops below 30 mph (50 km/h) or vehicle encounters hilly terrain. The overdrive can be engaged in 4th gear only.

The overdrive is engaged by pressing in the switch on the top of the gear lever. If the switch is pressed in once again the overdrive will be disengaged. Make a practice of always disengaging the overdrive when downshifting. However, if you should forget, the overdrive will nevertheless be automatically disengaged.

**When engaging and disengaging, depressing the clutch pedal slightly makes a smooth transfer.**

The overdrive should be used after the engine has reached normal operating temperature (minimum time is five minutes) and the vehicle is being operated on relatively level roads.

## Reversing inhibitor

Lift the ring to enter reverse gear.

The ring locking mechanism prevents reverse gear from being engaged unintentionally.

# Automatic transmission



## Shift positions

P park	D drive
R reverse	2 intermediate
N neutral	1 low

The gear selector can be moved freely between D and 2. The other positions are separated by a lockout which is operated by depressing the selector knob.

Depressing the selector knob slightly allows selection of positions **N** and **1**.

Depressing the selector knob fully allows selection of positions **R** and **P**. This is also necessary when initially bringing the selector out of position **P**.

Depressing the selector knob fully thus permits shifting freely between all positions.



56450

## P Park

Use this position when parked with the engine running or stopped.

**Never use P while car is in motion.**

The transmission is mechanically locked in position P. Also use the parking brake when parking on grades for added safety.

## R Reverse

**Never use R while car is moving forward.**

## N Neutral

Neutral position = no gear is engaged. **Use parking brake.**

## D Drive

D is the normal driving position. Upshift and downshift of the forward gears occurs automatically and is governed by acceleration and vehicle speed.

### 1, low position

If position 1 is selected when driving at high speeds, 2 is engaged first and 1 when the speed has dropped to approx. 30 mph (50 km/h).

**NOTE: No upshift once 1 is engaged.**

Use position 1 to select low gear with no upshift. For instance, when entering and descending steep grades.

### 2, intermediate position

Upshift and downshift of first two gears (low and intermediate) occurs automatically.

**No upshift to 3rd (top) gear occurs.**

Position 2 may be used to obtain forced downshift to 2nd gear for increased engine braking effect. Position 2 can also be used ...

- for relatively slow highway driving.
- for city driving.
- when driving on mountain roads where precise speed control is desirable.
- for passing.

**NOTE:**

- **Never select P or R while the car is in motion.**
- **When standing still and selecting D, 2, 1 or R the engine must be idling.**
- **When traveling abroad or for police use, the gear selector should not be downshifted to 2 or 1 at speeds above 75 mph (125 km/h).**



Overdrive indicator light.  
The light is on when  
overdrive is disengaged.

## Overdrive (certain models)

The transmission will automatically engage the overdrive after upshifting through first, second and third gears unless the overdrive-off button is pushed. The button is located on the side of the gear selector lever knob. When the button is pushed the OD OFF indicator light in the instrument panel goes on as a reminder. When the overdrive off button is pushed the transmission will immediately downshift from overdrive to third gear and will not shift into overdrive until the button is pushed again.

Since using the overdrive improves economy it should be used as often as possible. However, do not engage the overdrive when pulling a trailer.

The overdrive should be disengaged when driving in mountainous regions, when passing another car or when manually downshifting.

## Kick-down

Automatic shift to a lower gear is achieved by depressing the throttle pedal briskly (passing the normal full throttle position).

An up-shift will be achieved when approaching the top speed for a particular gear or by releasing the throttle pedal slightly.

Kick-down can be used for maximum acceleration or when passing at highway speeds.

## Starting and stopping a car equipped with automatic transmission

1. Fasten the seat belts.
2. Apply the parking brake or the brake pedal to hold the car (to prevent the car from moving when the gear selector is moved).
3. Select position **P** or **N**. (Engine cannot be started in any other position.)
4. Start the engine by turning the ignition key. (See Section "Starting the Engine".)
5. Select desired gear.
6. Release the brake and accelerate.

**To stop the car**, release the throttle pedal and apply the brakes.

It is not necessary to move the gear selector as the transmission will downshift automatically.

When idling for extended periods of time, select position **N** to prevent unnecessary heating of the transmission.

**WARNING! Always place gear selector in Park and parking brake on before leaving vehicle. Never leave car unattended with engine running.**



## Emergency towing (pulling)



Front eyelet (without air dam)



Front eyelet (with air dam)

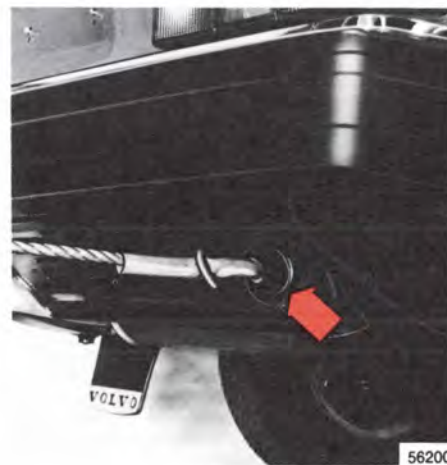

Rear eyelet

### Precautionary steps to observe when towing

Please check with state and local authorities before attempting this type of towing as vehicles being towed are subject to regulations regarding maximum towing speed, length and type of towing device, lighting, etc.

- Steering must be unlocked.
- Remember that power brake and power steering assists will not be available when engine is inoperative. Pedal pressure required is 3 – 4 times above normal and greater steering effort must be employed.
- **Towing cars equipped with automatic transmission:**
  - Gear selector in position N. Check transmission oil level (see section titled "Transmission oil").
  - Maximum speed: 20 mph (30 km/h).
  - Maximum distance: 20 miles (30 km).

**Jump starting, see section titled "alternator, jump starting".**

**CARS EQUIPPED WITH AUTOMATIC TRANSMISSION CANNOT BE STARTED BY PUSHING OR PULLING THE CAR.**



## FRONT

## REAR

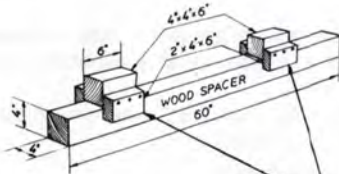

Wood spacer blocks adjustable to conditions

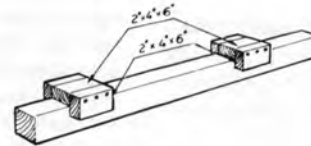

Front side member

Towing sling

Grease between bumper and towing sling

Tow bar

Auxiliary hooks

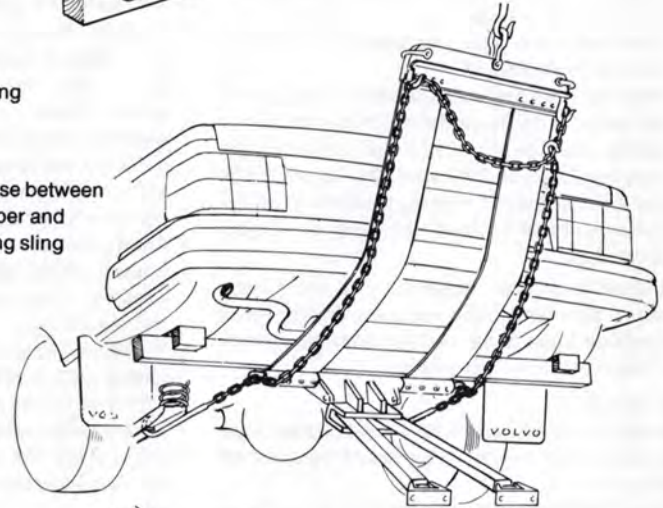
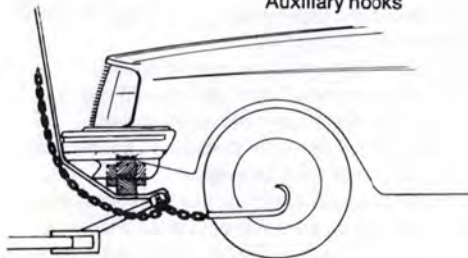

Grease between bumper and towing sling

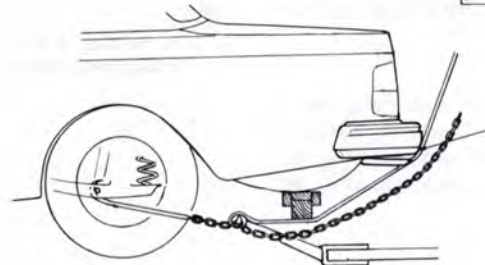

# Trailer hauling

## When preparing for trailer hauling, observe the following:

- Use a trailer hitch which meets Federal Safety Standards for rear end collisions (FMVSS 301-75). For trailer weights exceeding 2,000 lbs (908 kgs) use only a trailer hitch offered as a Genuine Volvo Accessory.
- Maximum trailer weight recommended by Volvo is 3,300 lbs (1,500 kg).

However, for cars with automatic transmission, an optional Volvo **automatic transmission oil cooler** must be installed when trailer weight exceeds 2,000 lbs (908 kgs). **Overdrive should not be used while towing.** Observe legal requirements of the state in which the vehicles are registered.

All Volvo models are equipped with energy absorbing shock mounted bumpers. Trailer hitch installation should not interfere with the proper operation of the bumper system.

### WARNING:

**Bumper-attached trailer hitches must not be used on Volvos, nor should safety chains be attached to the bumper.**

**Trailer hitches attaching to the vehicle rear axle must not be used.**

### NOTE:

Never connect a trailer's hydraulic brake system directly to the vehicle brake system, nor a trailer's lighting system directly to the vehicle lighting system. Consult your nearest authorized Volvo dealer for correct installation.

Trailer hauling does not normally present any particular problems, but take into consideration:

- Recommended hitch tongue load is 110 lbs (50 kgs) for trailer weights below 2,650 lbs (1,200 kgs) and 143-154 lbs (65-70 kgs) for trailer weights above 2,650 lbs (1,200 kgs). However, it must not exceed 200 lbs (90 kgs).
- For trailer weights between 2,650-3,300 lbs (1,200-1,500 kgs) a top speed of 50 mph (80 km/H) should never be exceeded.
- Engine and transmission are subject to increased loads. Therefore, engine coolant temperature should be closely watched when driving in hot climate or hilly terrain. Use lower gear and turn off air conditioner if temperature gauge pointer enters the red range.
- Avoid overload and other abusive operation.
- Hauling a trailer affects handling, durability and economy. Trailer air dam (Volvo accessory) will improve mileage.
- It is necessary to balance trailer brakes with the towing vehicle brakes to provide a safe stop (check and observe State regulations).
- More frequent vehicle maintenance is required.
- Remove the ball and drawbar assembly when the hitch is not being used.

### NOTE:

Refer to section entitled "Automatic transmission" for additional trailer hauling tips.

**WARNING:** Do not drive with trunk lid or tailgate open!

Poisonous exhaust gases may enter via the open trunk lid or tailgate. (This is especially true for wagon models.)

If the trunk lid or tailgate for any reason must be open, proceed as follows:

- Close the windows.
- Set the heating system controls FLOOR and DEF to max. and the blower to full speed (4). See section titled "Heating and Ventilation".

## Handling, roadholding

Vehicle load, tire design and inflation pressure are important for proper handling. Therefore check that the tires are inflated to the recommended pressure according to the vehicle load.

It is recommended to use tires of the same make and dimensions on all four wheels.

**CAUTION:** Do not mix radial ply and bias ply tires as this will adversely alter the vehicle handling characteristics.

## Roof rack (removable)

Permanent and removable roof racks are available from Volvo Accessories.

Observe the following points when in use.

- Avoid point loads. Distribute the load evenly.
- Place the heavy cargo at bottom of load.
- Observe that center of gravity and handling are influenced by the load weight.
- Increasing load size increases wind resistance.
- Anchor the cargo correctly with a cord.
- Drive carefully. Avoid rapid starts, heavy cornering and heavy braking.
- Max. roof load is 220 lbs (100 kg).

## The following "Special Tips" apply to cars with automatic transmission

- For steep hills and when driving for prolonged periods at low speeds position 1 should be selected. Avoid, however, repeated changes since this can cause overheating of the gearbox oil. For driving on mountain roads with long persistent uphill gradients, select position 2.
- When negotiating long, steep downhill slopes, position 1 should be selected and position 2 for less severe inclines, in order to obtain the best possible engine braking effect.
- Do not hold the car stationary on an incline by using the accelerator pedal, engage the hand-brake instead. This prevents the gearbox oil from becoming overheated.
- Overdrive must be disengaged when hauling a trailer!
- If an additional transmission oil cooler is installed you can haul a trailer with the overdrive engaged. See next "special tip".
- When driving with heavy trailers, it is recommended that an additional oil cooler be installed. This applies especially when driving hard e.g. mountain driving or prolonged driving at high speeds without breaks. The additional oil cooler is available as a genuine Volvo accessory. Regarding oil change, see section titled "Transmission oil".

## Moisture on brake discs and brake pads affects braking.

Driving in rain and slush or passing through a normal car wash can cause water to collect on the brake discs and pads. This will cause a delay in braking effect when the pedal is depressed. To avoid such a delay, when the brakes are needed, depress the pedal occasionally when driving. This will remove the water from the brakes. This should also be done after washing or starting in very damp weather.

## If the brake power assist does not function—

**The power assist to the brakes functions only when the engine is running.** When the car is moving without the engine running the brake pedal pressure required to stop the car is increased 3 — 4 times.

**The brake pedal feels stiff and hard.**

## If one of the brake circuits should malfunction the red warning light



will come on

56122/4  
(See section titled "Warning Lights".)  
The pedal stroke increases slightly and the pedal feels softer but the pedal pressure required does not increase noticeably.  
**Drive cautiously to a Volvo dealer or Service Station to have the brake system checked.**

## Severe strain on the brake system

The brakes will be subject to severe strain when driving in mountains or hilly areas. The speed is usually low which means that the cooling of the brake is less efficient than when driving on level roads.

To reduce the strain on the brakes it is advisable not to use the brakes excessively. Instead, shift into a lower gear and let the engine help with the braking. A good rule is to use the same gear downhill as would be used uphill. For vehicles with automatic transmission use position 2 or in some cases 1.

## Air dam (front spoiler)

An air dam can negatively influence the normal flow of cooling air to the front wheel brakes. (See section titled "Wheels and Tires").

### Catalytic Converter Cautions (all U.S.A. and certain Canadian models)



56258

- Keep your engine properly tuned. Certain engine malfunctions, particularly involving the electrical, fuel or ignition systems, may cause unusually high converter temperatures. **Do not continue to operate your vehicle if you detect engine misfire, noticeable loss of power or other unusual operating conditions**, such as engine overheating, repetitive stalls or backfires. A properly tuned engine will help avoid malfunctions that could damage the Catalytic Converter.
- Remember that tampering or unauthorized modifications to the engine or the vehicle may be illegal and can cause catalyst or exhaust system overheating. This includes:
  - Altering fuel injection settings or components.
  - Adjusting ignition timing beyond specified limits.
  - Altering emission system components or location or removing components.
- Do not park your car over combustible materials, such as grass or leaves, which can come into contact with the hot exhaust system and cause such materials to ignite under certain wind and weather conditions.
- Excess starter cranking (in excess of one minute) with an intermittently firing or flooded engine, can cause catalyst or exhaust system overheating. This also applies to lengthy pushing or towing of vehicle to start (manual transmissions only).

**NOTE: Unleaded fuel is required for cars with catalytic converter. A label on the instrument panel and rear fender, near the filler inlet, will remind owners and filling station attendant of this requirement. Important! It is unlawful to dispense leaded fuel into any vehicle labeled "unleaded gasoline only".**



# MAINTENANCE

## Maintenance services

Your Volvo has passed two major inspections before it was delivered to you, according to Volvo specifications. When driven 600—1,200 miles (1,000—2,000 km), your car should be brought to the Volvo dealer for a service inspection. Engine, manual transmission and rear axle oils, will be changed at this time.

**Following this inspection, maintenance inspections as outlined in this book should be performed every 7,500 miles (12,500 km).**

The extended maintenance inspection intervals make it even more advisable to follow this program.

Inspection and service should also be performed any time a malfunction is observed or suspected.

It is recommended that receipts for vehicle emission services be retained in the event questions arise concerning maintenance. See your "Warranties and Maintenance Records Manual".

## Maintenance inspection 7,500 mile (12,500 km) intervals

Volvo advises you to follow the inspection program at 7,500 mile (12,500 km) intervals which is outlined in the "Warranties and Maintenance Records Manual". This maintenance program contains inspections and services necessary for the proper function of your car over the next 7,500 miles (12,500 km).

The maintenance inspections contain several checks which require special instruments and tools and therefore must be performed by a qualified technician.

To keep your Volvo in top condition, specify time tested and proven Genuine Volvo Parts and Accessories.

## THE FEDERAL CLEAN AIR ACT (USA)

The Clean Air Act requires vehicle manufacturers to furnish written instructions to the ultimate purchaser to assure the proper functioning of those components that control emissions.

The maintenance instructions listed in the "Servicing" section of this Manual represent the minimum maintenance required. These services are not covered by the warranty. You will be required to pay for labor and material used. Refer to your "Warranties and Maintenance Records Manual" for further details.

In accordance with Federal Regulations, your Volvo is warranted to meet certain Emission Performance Standards. Refer to your Warranties and Maintenance Records Manual for detailed information concerning:

- Emissions Performance Warranty
- Limited 12-Month New Car Warranty
- Limited 12-Month Replacement Parts and Accessories Warranty
- Extended Limited Warranty on Dealer Demonstrators
- Limited 5-Year/50,000 Mile Emission System Warranty

**Note:** The above pertains to USA vehicles only.

# Servicing

## MAINTENANCE SCHEDULE

A = Adjust (Correct if necessary)  
R = Replace

I = Inspect (Correct or Replace if necessary)  
L = Lubricate

Maintenance Operation	Miles (Km)	600— 1,200 (1,000— 2,000)	7,500 (12,500)	15,000 (25,000)	22,500 (37,500)	30,000 (50,000)	37,500 (62,500)	45,000 <sup>6)</sup> (75,000)	Description on page
<b>EMISSIONS SYSTEM MAINTENANCE</b>									
Engine Oil and Oil Filter Except Turbo Engines <sup>1)</sup>		R	R <sup>2)</sup>	R <sup>2)</sup>	R <sup>2)</sup>	R <sup>2)</sup>	R <sup>2)</sup>	R <sup>2)</sup>	51
Engine Oil and Oil Filter, Turbo Engines <sup>2)</sup>		R	R <sup>2)</sup>	R <sup>2)</sup>	R <sup>2)</sup>	R <sup>2)</sup>	R <sup>2)</sup>	R <sup>2)</sup>	48
Cooling System Hoses and Connections		I							53
Engine Drive Belts		A				I			53
Torque Manifold Nuts		A							54
Valve Clearance						I			54
Camshaft Drive Belt <sup>4)</sup>		A						R <sup>4)</sup>	54
Vacuum Fittings, Hoses and Connections		I							54
Oxygen sensor (except B21A)						R			56
Reset Service Indication for Oxygen Sensor (except B21A)						A			56
Air Cleaner Filter						R			56
Idle RPM		I		I <sup>5)</sup>		I <sup>5)</sup>		I <sup>5)</sup>	57
Fuel System Cap, Tank, Lines and Connections		I							57
Spark Plugs				R <sup>7)</sup>		R		R <sup>7)</sup>	58
Ignition Timing (B21A Canada only)		I	I	I	I	I	I	I	58
Converter Mounting Bolts		A							59
Manual Transmission Oil		R	I	I	I	I	I	I	60
Automatic Transmission Oil <sup>3)</sup>		I	I	I	R	I	I	R	61
Rear Axle Oil		R	I	I	I	I	I	I	62

1) Oil and oil filter cartridge are first changed at the 600—1,200 mile (1,000—2,000 km) inspection. Subsequent oil and filter changes should be made at 7,500 mile (12,500 km) intervals or at least every sixth month, whichever occurs first.

2) Oil and oil filter cartridge are first changed at the 600—1,200 miles (1,000—2,000 km) inspection. Subsequent oil and filter changes should be made at 3,750 mile (6,250 km) intervals or at least every sixth month, whichever occurs first.

However, adverse conditions (like hot ambient temperatures, trailer hauling, hill climbing, driving long distances at high speeds, extended periods of idling or low speed operation, short trip operation at freezing temperatures require oil changes more frequently (every third month).

3) Check the oil level (at least every sixth month).

4) Not included in emissions systems maintenance but we recommend that the camshaft drive belt should be replaced every 45,000 miles (75,000 km).

5) Except engines equipped with constant idle speed system.

6) For service intervals beyond 45,000 miles (75,000 km) refer to the Maintenance Service Schedules Chart provided with your vehicle.

7) Canadian models only.

Maintenance Operation	Miles (Km)	600— 1,200 (1,000— 2,000)	7,500 (12,500)	15,000 (25,000)	22,500 (37,500)	30,000 (50,000)	37,500 (62,500)	45,000 (75,000)	Description on page
<b>MISCELLANEOUS MAINTENANCE</b>									
<b>ENGINE</b>									
Engine Coolant						R			53
Fuel (Line) Filter									56
Carburetor, damper cylinder oil (carburetor engines)		I		I		I		I	57
Choke and fast idle (carburetor engines)		I		I		I		I	57
PCV Nipple (Orifice)				2)		2)		2)	58
Ventilation Hoses									58
<b>BRAKES</b>									
Inspect Brakes. Replace components as necessary			I			I		I	62
Change Brake Fluid <sup>1</sup>						R			
<b>STEERING</b>									
Tire Wear (Align front end if needed.)		I	I	I	I	I	I	I	72
Check power steering fluid level.		I	I	I	I	I	I	I	62
<b>BODY</b>									
Trunk, Door and Hood Hinges and Latches.		L	L	L	L	L	L	L	63

<sup>1)</sup> For cars equipped with air dam, the brake fluid should be changed every 15,000 miles (25,000 km) or once a year.

<sup>2)</sup> Volvo recommends that the flame guard be cleaned every 15,000 miles (25,000 km).



# Servicing Engine

The following items should be checked weekly by the driver. (This only takes a few moments.)

Engine oil level

Description  
on  
page

51

Brake fluid

62

Radiator coolant level

64

Tire pressure, all five tires

72, 93

Operation of all lights

—

Horns

—

Windshield wipers

—

Level of windshield fluid

—

The following should also be carried out at regular intervals.

Description  
on  
page

Washing

76

Polishing

77

Cleaning

77

Rust protection

77

48

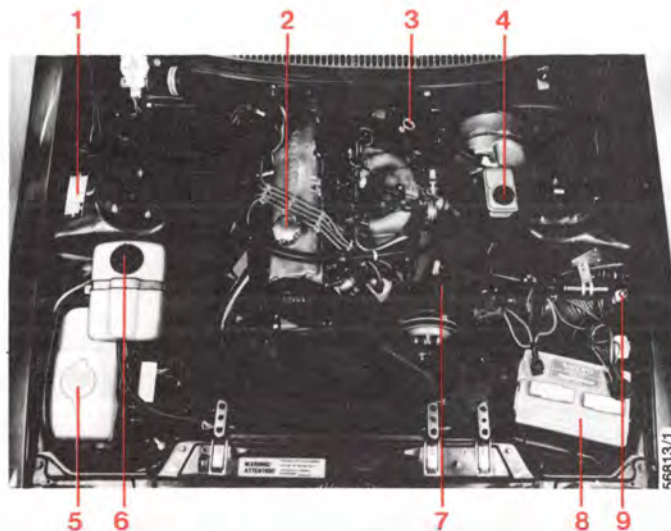

## Engine B23F

- 1 Data plate
- 2 Oil filler cap, engine
- 3 Oil dipstick, engine
- 4 Brake fluid reservoir
- 5 Washer fluid reservoir
- 6 Expansion tank, coolant
- 7 Oil reservoir, power steering
- 8 Battery
- 9 Fuse, engine control (B23F)

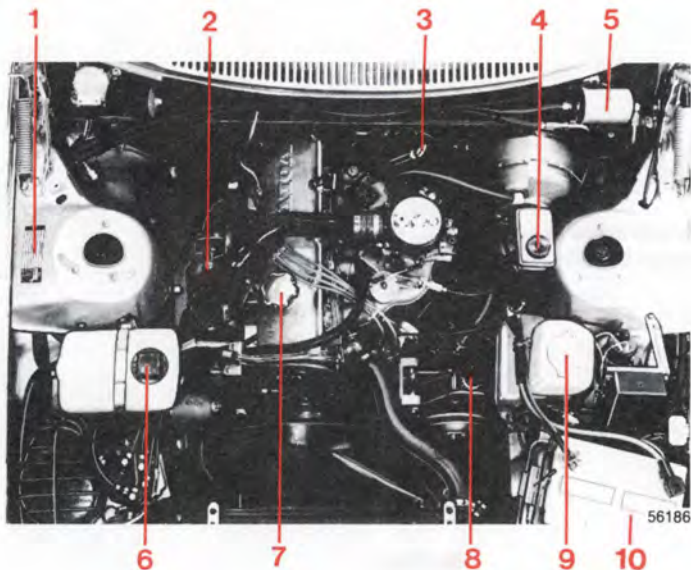

**Engine B 21F Turbo**

- |                         |                                 |
|-------------------------|---------------------------------|
| 1 Data plate            | 6 Expansion tank, coolant       |
| 2 Turbo charger         | 7 Oil filler cap, engine        |
| 3 Oil dipstick, engine  | 8 Oil reservoir, power steering |
| 4 Brake fluid reservoir | 9 Washer fluid reservoir        |
| 5 Fuel filter           | 10 Battery                      |

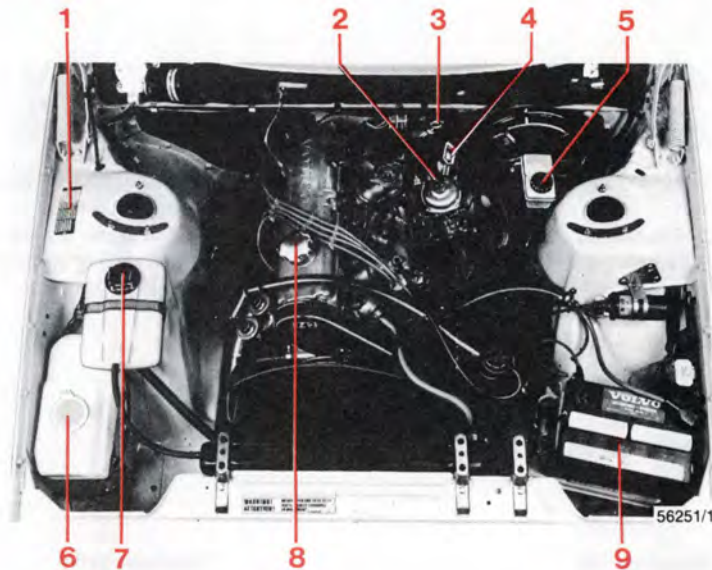

**Engine B 21A, Canada**

- |                                        |                           |
|----------------------------------------|---------------------------|
| 1 Data plate                           | 6 Washer fluid reservoir  |
| 2 Carburetor                           | 7 Expansion tank, coolant |
| 3 Oil dipstick, engine                 | 8 Oil filler cap engine   |
| 4 Oil dipstick, automatic transmission | 9 Battery                 |
| 5 Brake fluid reservoir                |                           |

# Gas station checks

---

## Fuel

### Octane rating

B21 F Turbo and B23 F: 91 RON-87 (R + M)/2  
(unleaded regular)

B 21 A:97 RON-91 (R+M)/2 leaded  
or 96 RON-91 (R+M)/2  
unleaded (premium fuel)

**Unleaded fuel must be used** for vehicles with catalytic converter.

Vehicles not equipped with catalytic converter can use leaded or unleaded gasoline. (See section on "Fuel tank cap".)

## Engine oil

Maintain oil level between the dipstick marks. The distance between the marks represents 1 quart (1 liter). Engine oil "**For API Service SF-CC**".

(See section titled "Engine oil")

## Coolant

Maintain fluid level between MAX and MIN marks on expansion tank.

Mixture of 50 percent Volvo anti-freeze type C (blue-green) or corresponding and 50 percent water should be used.

## Washer fluid

Washer fluid reservoir.

Water and solvent (wintertime use windshield washer anti-freeze).

## Brake fluid

Check that the level is above the MIN mark, without removing the cap.

Brake fluid DOT 4.

## Battery

Check level in conjunction with normal service or once a year.

Electrolyte level  $\frac{1}{4}$ " -  $\frac{3}{8}$ " (5-10 mm) above plates.

Use distilled water. **Never add acid.**

### Warning:

**Battery gases are explosives if brought in contact with open flame or sparks.**



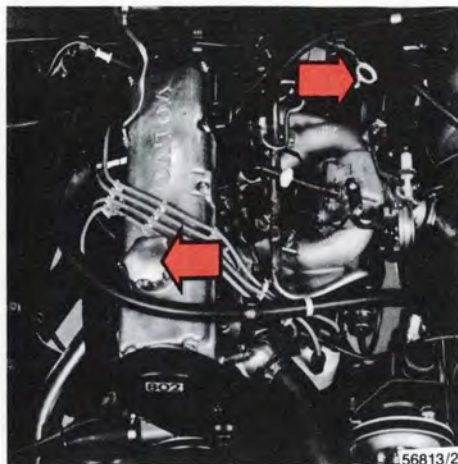

56813/2

## Checking oil level

The oil level should be checked each time the fuel tank is refilled. Be sure the oil level is maintained between the upper and lower marks on the dipstick. Low oil level can cause internal damage to the engine and overfilling can result in high oil consumption. The distance between the dipstick marks represents 1 quart (1 liter) of oil.

## To add or change oil

Add oil of the same kind as already used. See engine oil section.



54246

## Changing oil filter

Replace the oil filter at every oil change. If the oil filter is changed separately  $\frac{1}{2}$  US qt = .5 liters of oil should be added.

# Engine Oil

## Oil quality

### According to API Service — minimum SF\*

\*Oils with designations SF/CC and SF/CD comply with the above.

Synthetic or semi-synthetic oils may be used if their specifications comply with above.

It is recommended that you select an oil not only of the proper quality and viscosity, but also a fuel-saving product. When using these oils the Volvo recommended oil change intervals must be followed.

**Viscosity:** (Stable ambient temperatures).

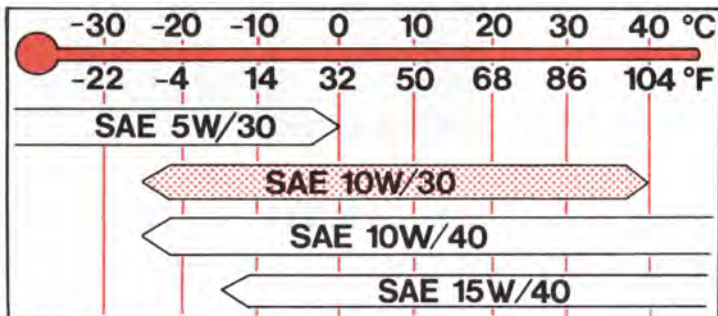

57139

SAE 15W/40 oil is recommended for use in extreme driving conditions that involve high oil temperature and consumption e.g. mountain driving with frequent decelerations or fast motorway driving.

(Note however the lower temperature limits.)

## Capacity

**Including oil filter:** 4.0 US qts = 3.85 liters

**Excluding oil filter:** 3.5 US qts = 3.35 liters

For turbo equipped cars add 0.7 US qts = 0.6 liter to the above capacities.

**Check oil level:** When filling fuel.

**Oil change:** (either mileage or month interval whichever comes first).

Driving conditions	Without Turbo	With Turbo
Driving under adverse conditions — see below	Each 7,500 miles (12,500 km) or every third month	Each 3,750 miles (6,250 km) or every third month
Normal driving conditions	Each 7,500 miles (12,500 km) or every sixth month	3,750 miles (6,250 km) or every sixth month

## Adverse Driving Conditions

- sustained driving in dusty/sandy conditions
- sustained trailer hauling
- sustained hill climbing
- sustained high speed driving
- sustained low speed driving or idling
- when driving short distances (7 miles = 10 km) at low temperatures (32° F = 0° C)



## Changing coolant

Every two years or 30,000 miles (50,000 km) the cooling system should be drained, flushed and refilled. Remove the expansion tank cap. Open the drain cock on right side of the engine block and disconnect the lower radiator hose.

### Fill coolant through the expansion tank.

**The heater controls should be fully open when draining and filling.**

Add coolant until the level is up to the MAX mark or slightly above.



## Cooling system, hoses and connections

Check all cooling system hoses and connections for defects or deterioration of hoses and loose clamps or fittings.

Start engine and run until hot. Check the cooling system connections for tightness. Also re-check the coolant level. Capacity: 9.9 US qts. = 9.4 liters.

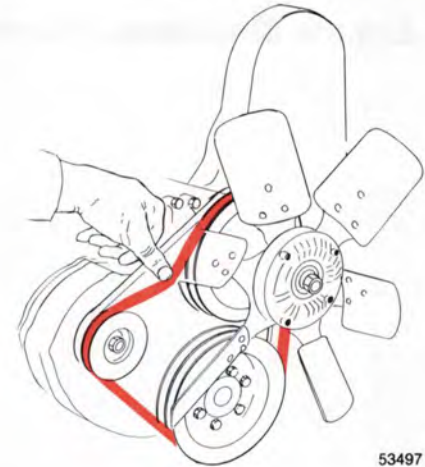

## Drive belts

The belt tension can be checked by depressing the fan belt at a point midway between the alternator and fan pulleys as illustrated. It should be possible to press down the belt about  $\frac{1}{4}$ " -  $\frac{3}{8}$ " (5-10 mm). This also applies to other drive belts on the engine.



## I Engine Mechanical Components

### **Torque manifold nuts**

The manifold nuts should be torqued at the 600-1,200 mile (1,000-2,000 km) inspection. A loose manifold could alter air/fuel ratio and cause an increase in emission and/or poor driveability.

### **Valves**

The valve clearance should be checked every 30,000 miles (50,000 km).

### **Vacuum fittings, hoses and connections**

Unstable idle, misfiring or poor emission control is often caused by leaking vacuum hoses or connections. Check hoses and connections on distributor vacuum unit, EGR valve (when applicable) and connections on heater control servo systems and hydraulic brake servo.

### **Camshaft drive belt**

The camshaft drive belt tensioner should be adjusted at the 600-1,200 mile inspection.

## II Engine Fuel System

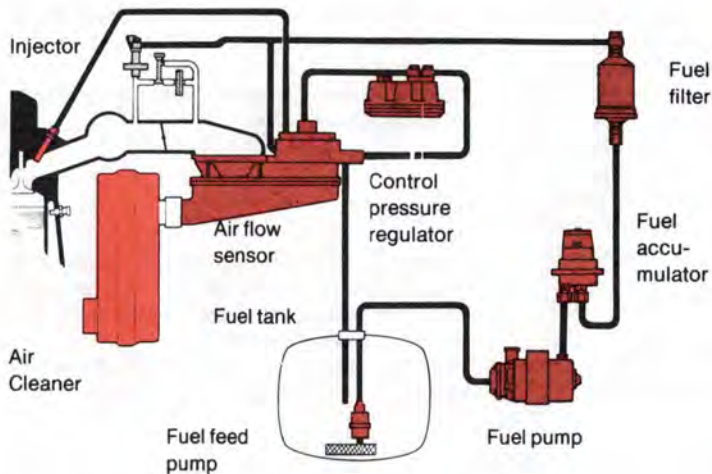

55120

### CI system (Continuous Injection)

Fuel injectors are open and inject fuel as long as the engine is operating. This system has few moving parts, is reliable and meets the exhaust emission standards at maximum efficiency.

Air supplied to the engine is continuously measured and determines the amount of fuel injected.

The air flow is regulated by the throttle valve. The air flow sensor and the fuel distributor are integrally built as a single unit. A lever is actuated by the air flow to produce continuous fuel distribution.

### Electronic control unit

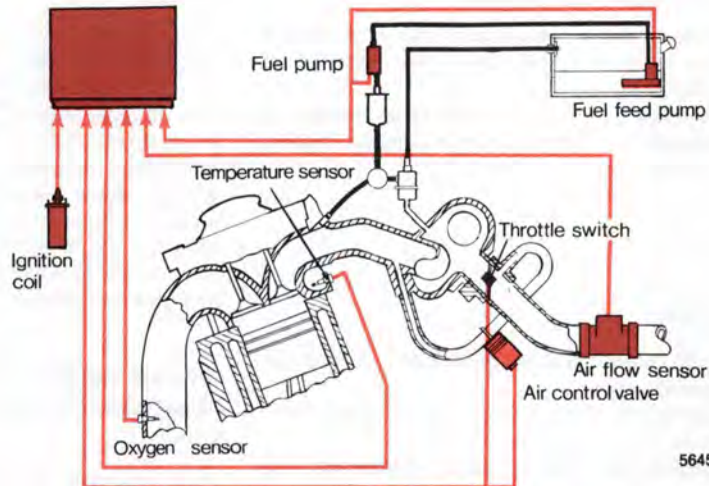

56453

### LH-Jetronic System

The LH-Jetronic fuel injection system is all-electronic and is microprocessor controlled. It can continually compensate for variations in engine load, speed and temperature to give the best economy and power. The most unique feature of the system is the airflow meter which measures the mass of the inducted air instead of the volume. In this way the system can make instantaneous adjustments for changes in air temperature or density thus always assuring the best economy with the lowest exhaust emissions.

## Special instructions for work on the fuel injection system

Extreme cleanliness is essential when working on the injection system. Great care must be observed.

Injection system service should be handled by qualified technicians, using equipment intended for this service.

## Fuel

**B21F Turbo and B23F:** 91 RON-87 (R+M)/2 (unleaded regular)

**B21A:** 97 RON-91 (R+M)/2 leaded or 96 RON-91 (R+M)/2 unleaded (premium fuel)

**Unleaded fuel must be used** for vehicles with catalytic converter.

Vehicles not equipped with catalytic converter can use leaded or unleaded gasoline.

**A label on the instrument panel and on the rear fender, near the filler inlet, will remind of this requirement.**

**It is unlawful to dispense leaded fuel into a vehicle labeled "unleaded gasoline only".**

Volvo cars are designed to operate on unleaded gasoline. The use of fuels containing alcohol may adversely affect certain components and/or systems performance.

## Lambda-sond<sup>™</sup> (oxygen sensor) system

This is an emission control system designed to reduce emissions and improve fuel economy. An oxygen sensor monitors the composition of the exhaust gases leaving the engine. The exhaust gas analysis is fed into an electronic unit which continuously influences the amount of fuel injected. This adjusts the air-fuel ratio to provide optimum conditions for combustion and efficient reduction of the three major pollutants (hydrocarbons, carbon monoxide and nitrogen oxides) through a 3-way catalytic converter.

## Change oxygen sensor unit. Reset service indication for oxygen sensor.

The oxygen sensor must be replaced every 30,000 miles (50,000 km).

To remind the driver about the change of the oxygen sensor unit there is a special reminder light. (See section titled "Warning Lights".) The light will stay on until reset.

**Note:** Failure to follow the recommended maintenance may result in vehicle not meeting Federal or state emissions standards.

## Fuel (line) filter

We recommend that this filter be changed every 60,000 miles (100,000 km). The filter is replaced as one complete unit.

Replace more frequently if contaminated fuel was introduced into the tank.

## Air cleaner

Replace the air cleaner cartridge with a new one every 30,000 miles (50,000 km). The cartridge should be replaced more often when driving under dirty and dusty conditions.

The filter cannot be cleaned and, therefore, should always be replaced with a new one.



## Checking and adjusting idling speed

The idling speed should be adjusted every 15,000 miles (25,000 km).

Vehicles equipped with the Volvo Constant Idle Speed System do not require idle speed adjustment.

## Fuel system cap, tank and lines, and connections

The effectiveness of the fuel system to contain hydrocarbons is largely dependent on a leak-free system. Check for proper sealing of gasoline filler cap which contains "O" ring type seals. Check all evaporative hoses in vehicle for tightness. Check fuel lines under vehicle and repair if necessary.



## Carburetor (Certain Canadian models)

The damper oil level should be up to about  $\frac{1}{4}$ " (6 mm) from the edge of the center spindle. If necessary, top-up with Automatic Transmission Fluid.

**Oil quality:** Automatic Transmission Fluid

**Oil capacity:** 4,5 cc

**Oil-level check:** At 600-1,200 miles (1,000-2,000 km) and every 15,000 miles (25,000 km) thereafter.

**Oil change:** No change needed.

## Choke and fast idle

On carburetor engines, the choke and fast idle function should be checked at 600-1,200 miles (1,000-2,000 km) and every 15,000 miles (25,000 km) thereafter.

## III Engine Ignition Components

### Change spark plugs

The spark plugs should be changed every 30,000 miles (50,000 km). Canada: every 15,000 miles (25,000 km).

However, city driving or fast highway driving may require changing after 7,500 miles of driving. When fitting new plugs, be sure to fit the right type: Engine B21F Turbo and B23F: Volvo Part No. 273594-2 (Bosch WR7DS) or equivalent. Engine B 21A: Volvo Part No. 273597-5 (Bosch W7DC) or equivalent. Torque to 7-10 ft. lbs. (10-14 Nm).

When changing the spark plugs, check that the suppressor connectors are in good condition. Cracked or damaged connectors should be replaced.

When changing spark plugs, clean the cables and cable terminals, also the rubber seals. If the car is driven on roads where salt is used during the winter, coat the cables with silicone.

### Ignition timing (B21A Canada only)

The ignition timing should be inspected at the 600—1,200 mile (1,000—2,000 km) inspection and at every 7,500 mile (12,500 km) service.

All adjusting work should be done with the proper equipment. The distributor is one of the most sensitive engine units. Careless handling can lead to decreased engine output and high fuel consumption or even serious damage to the engine.

#### **WARNING!**

The ignition system operates at very high voltages. Special safety precautions must be followed to prevent injury:

Always turn the ignition off when:

- connecting engine test and diagnostic equipment to the vehicle (timing light, tach-dwell tester, ignition oscilloscope, etc.).
- Replacing ignition components e.g. plugs, coil, distributor, HT leads etc.

## IV Engine Crankcase Ventilation System

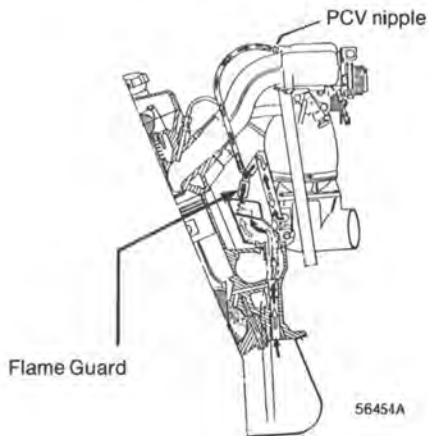

### Crankcase ventilation

The engine is provided with positive crankcase ventilation which prevents crankcase gases from being released into the atmosphere. Instead, the crankcase gases are admitted to the intake manifold and cylinders.

### Cleaning PCV valve

The calibrated positive crankcase ventilation nipple should be cleaned every 60,000 miles (100,000 km). On 4-cylinder engines (except B21F Turbo), it is recommended that the flame guard be cleaned every 15,000 miles (25,000 km).

## VI Engine Evaporative Emissions



56458

### Catalytic Converter

This is a supplementary device in the exhaust system, designed to reduce exhaust emissions.

This device is mainly a container with a ceramic material insert, designed to let the exhaust gases pass through channels in the insert. The channel walls are covered by a thin layer of platinum and rhodium. These metals act as catalysts, permitting a chemical action to occur without actually taking part in it.

The carbon monoxide content will increase if the Catalytic Converter is damaged.

#### CAUTION:

**Vehicles with Catalytic Converter must use unleaded fuel only. Otherwise the Catalytic Converter will become damaged and ineffective.**

### Torque catalytic converter mounting bolts (all U.S.A. models and certain Canadian models)

The Catalytic Converter mounting bolts should be re-torqued at the 600—1,200 mile inspection.

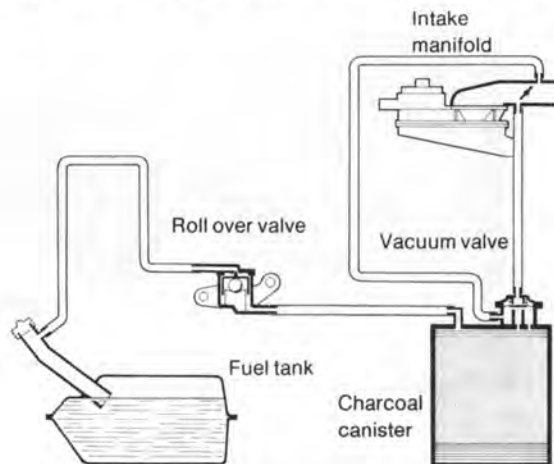

55817

### Evaporative control systems

Vehicles intended for the North American market are equipped with a fuel vapor evaporative control system, which prevents gasoline fumes from being released into the atmosphere.

The system is comprised of an expansion chamber in the fuel tank, a roll-over valve on the cross member in front of the fuel tank, and a charcoal canister with built-in vacuum valve under the left front wheel housing. The components are interconnected by hoses which channel fuel vapor from the gas tank to the charcoal filter where they are stored until the engine is started and then drawn into the engine fuel induction system.



# Transmission oil

*Gearbox*

*Overdrive*

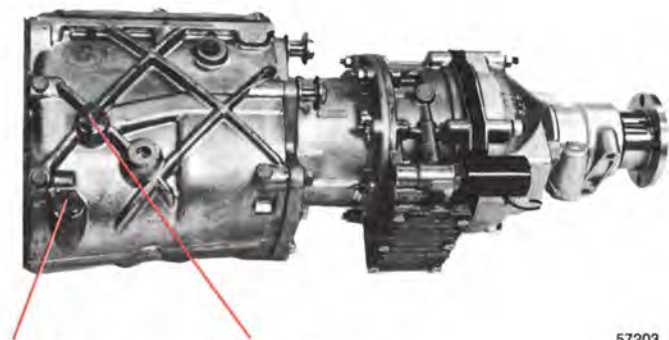

57203

*(B) Drain plug*

*(A) Level/filler plug*

## Manual transmission with overdrive, M46

Capacity: 2.4 US qts = 2.3 liters.

Fluid type: Automatic Transmission Fluid Type F or G (FLM)

Engine oil SAE 10W-40 is recommended for use in areas where the temperature seldom drops below 14° F (-10° C).

Note! Do not mix ATF and engine oil.

Replace: at 600—1,200 mile (1,000-2,000 km) service only.

The oil level should be up to the filler plug (A). Drain the oil immediately after driving, while it is still hot by removing plug (B).

Transmission and overdrive are lubricated by the same oil. Therefore, when the oil is drained through plug B, also remove cover on the overdrive and clean strainer.

Note: Refer to "Specifications" section of this manual for additional information on transmissions.

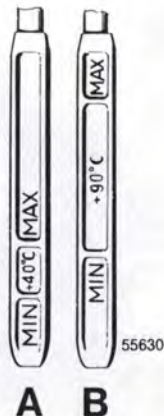

## Automatic transmission

Capacity: (with overdrive) 7.8 US qts = 7.4 liters.  
(without overdrive) 7.1 US qts = 6.7 liters.

Fluid type: BW55: Automatic Transmission Fluid type G (FLM)  
AW71: Automatic Transmission Fluid type Dexron II D.

Replace: every 22,500 miles (37,500 km).  
(See also section titled "Trailer hauling".)

### A Cold gearbox oil — oil temperature + 105 °F (+ 40 °C).

This is a normal temperature for the transmission after idling for about 10 minutes.

At oil temperature below +105 °F (+40 °C), the level may be below the MIN mark.

### B Warm gearbox oil — oil temperature + 195 °F (+ 90 °C).

This temperature is obtained when driving for about 30 minutes.

At oil temperature above +195 °F (+90 °C), the level may be above the MAX mark.

### Note!

**The engine should be idling when checking transmission fluid level.**

Check the oil level as follows:

**Park the car on level surface with the engine idling.**

Slowly move the selector lever through all the gear positions and then to position P. Wait 2 minutes before checking the oil level. As the illustration shows, the dipstick has a "Cold" and a "Warm" side.

The oil level should be between the MIN and MAX marks.

Wipe the dipstick with a clean cloth. CAUTION! The oil may be very hot!

Do not use rags which can leave lint on the dipstick.

The transmission is topped up via the dipstick tube.

The space between the MIN and MAX marks on the dipstick corresponds to 0.5 liter. Do not fill the transmission with too much oil, since this can result in oil being ejected from the transmission.

Too little oil, on the other hand, can negatively affect transmission operation, particularly in very cold weather.

## Rear axle, power steering, brake fluid

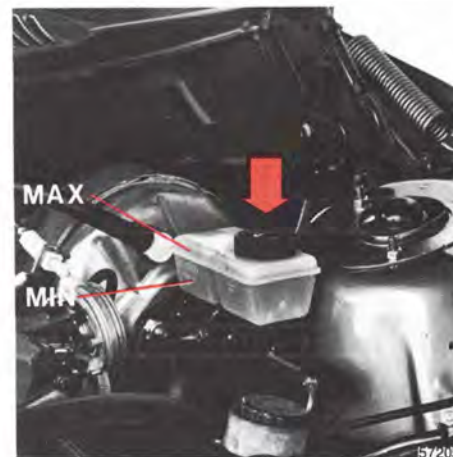

### Rear axle

Capacity: 1.7 US qts = 1.6 liters.  
Oil type: API GL-5 (MIL-L-2105 B or C)  
Viscosity: SAE 90 or 80W/90  
Replace: at 600–1,200 mile (1,000-2,000 km) service only.

The oil level should be up to the filler plug (A).  
Drain rear axle oil through drain plug (B).  
When the temperature is steadily below 15 °F (–10 °C), use API GL-5 SAE 80 W oil.  
Cars equipped with limited slip differentials should use oils with proper additives.

### Power steering

Capacity: 0.8 US qts = 0.75 liters.  
Fluid type: ATF  
Replace: no fluid change required.

The dipstick is attached to the cap and has level marks for both warm and cold fluid. Before driving the fluid level must **not** be over the COLD mark. After driving, when the fluid is warm, the fluid level must **not** be over the HOT mark. Add fluid when the level is at the ADD mark.

### Brake fluid

Fluid type: DOT 4  
Replace: every second year or 30,000 miles (50,000 km).

Check, without removing the cap, that the level is above the "MIN" mark of the fluid reservoir. Always entrust brake fluid changing to a Volvo dealer.

Change brake fluid every year when driving under extremely hard conditions (mountain driving etc.) and if the car is equipped with an air dam.



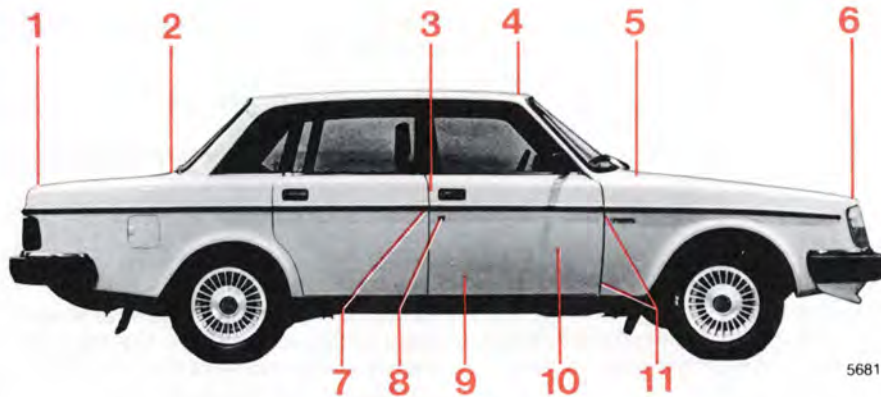

56814

## Chassis maintenance

To simplify maintenance, your Volvo has been equipped with ball joints, steering rods and propeller shafts that do not require regular lubrication.

Points that normally require lubricating have been packed with very durable grease at the factory and then carefully sealed, eliminating the need for subsequent lubrication.

## Lubricate body

To avoid rattles and unnecessary wear, the body should be lubricated once a year. Hinges on hood, doors and trunk lid as well as door stops should be lubricated every 7,500 miles (12,500 km).

During winter, locks in the doors and trunk lid should be treated with special anti-freeze lubricant to prevent freezing.



54051

## Door hinges (lower) and door stop

A grease B oil

### No. Lubricating point

No. Lubricating point	Lubricant
1 Trunk lid lock	Lock oil
2 Trunk lid hinges	Oil
3 Door lock outer sliding surfaces	Paraffin wax
4 Sunroof wind deflector	Oil
5 Hood hinges	Oil
6 Hood lock	Paraffin wax
7 Striker plate	Paraffin wax
8 Key holes	Lock oil
9 Front seat slide rails and latch devices	Oil
10 Window regulator	Oil, grease
Locking device (Accessible after door upholstery panels removed)	Silicon grease
11 Door hinges	Grease
Door stop	Oil



## Check coolant level

The cooling system must be filled with coolant and not leak to operate at maximum efficiency. Check the coolant level when filling fuel. The level should be between the "Max" and "Min" marks on the expansion tank. The check should be made with particular thoroughness when the engine is new or the cooling system has been drained.

Do not remove the filler cap other than for topping-up with coolant. Frequent removal may prevent coolant circulation between the engine and the expansion tank during engine warm-up and cooling.

### CAUTION

The cooling system must always be kept filled to correct level.

If it is not kept filled, there can be high local temperatures in the engine which could result in damage.

## Top up with coolant

Top up with coolant by filling the expansion tank when level is at the "Min" mark. Use a mixture of 50 percent Volvo Type C coolant and 50 percent water all the year round. Top up to the "Max" mark.

**If the engine is warm, and you are going to top up coolant, unscrew the cap slowly in order to allow any excess pressure to escape.**

NOTE: Do not top up with water only. Water by itself reduces the rust-protective and anti-freeze qualities of the coolant and has a lower boiling point. It can also cause damage to the cooling system if it should freeze.

See "Specifications" section of the manual for type of coolant recommended.

## Cooling system

The risk for overheating is greatest, especially in hot weather, when:

- towing a trailer up steep inclines for prolonged periods at full throttle.
- idling for prolonged periods while the air conditioning system is in operation.
- stopping the engine suddenly after high speed driving, so-called after-boiling.

To avoid overheating, the following rules should be followed.

- Reduce speed and downshift when towing a trailer up long steep inclines. The risk of overheating can be reduced by switching off the air conditioning system for a short while.
- Do not let the engine idle unnecessarily.
- Do not stop the engine immediately after high-speed driving, but allow the engine to idle for  $\frac{1}{2}$ —1 minute before switching off.

When the risk of overheating is imminent, or in the event of overheating, (the temperature gauge goes repeatedly into, or stays continually in, the red section) the following precautions should be taken:

- Switch off the air conditioning system.
- Stop the car and put the gear lever into neutral position-position N. **Do not stop the engine!**
- Increase the engine speed to approx. 2000 r/min (twice idling speed).
- Check the level of coolant in the expansion tank. Top-up, if necessary.



## Note:

### This car is equipped with an alternator

When changing the battery or when carrying out work involving the electrical system, the following should be observed.

- 1 A battery connection to the wrong terminal will damage the diodes. Before connections are made, check the polarity of the battery with a voltmeter.
- 2 If booster batteries are used for starting, they must be properly connected to prevent the diodes from being damaged. For correct connection, see next section titled jump starting.
- 3 The battery leads should be disconnected any time the battery is being charged.
- 4 Never disconnect the battery circuit (for example, to change the battery) while the engine is running, as this will immediately ruin the alternator. Always make sure that all the battery connections are cleaned and properly tightened.
- 5 If any electrical welding work is performed on the vehicle, the ground lead and all the connecting cables of the alternator must be disconnected and the welder wires placed as near the welding point as possible.

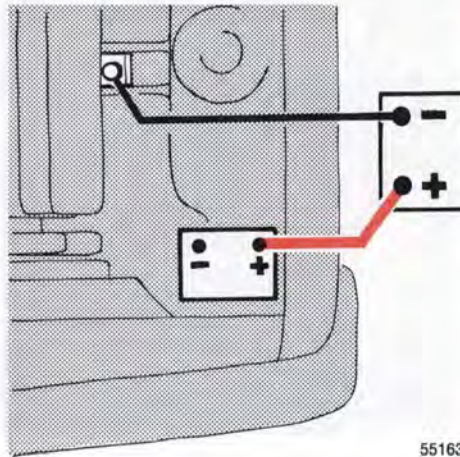

55163

## Jump starting

**CAUTION: Improper hook-up of jumper cables or the use of other than 12 volt batteries could result in damage to equipment and/or battery.**

Check that cars are not touching to prevent premature completion of negative circuit. Note the position of the battery terminals and using jumper cables, first connect booster battery positive terminal (+) to car battery positive terminal (+). Then connect booster battery negative terminal (-) to a stationary solid metal part on the engine at a point away from the battery. Do not connect to any part of fuel system or any moving parts. Avoid touching hot manifolds.

## WARNING!

To prevent possible explosion, never expose battery to open flame or electric spark. Do not smoke near battery. Batteries generate hydrogen gas which is flammable and explosive.

Battery fluid contains sulfuric acid.

Do not allow battery fluid to contact eyes, skin, fabrics or painted surfaces. If contact occurs, flush affected area immediately with water.

Obtain medical attention if eyes are affected.

After engine has started remove negative terminal (-) jumper cable first then positive terminal (+) jumper cable.

# Replacing bulbs

## Replacing bulbs

The replacement of bulbs in the various lighting units is shown on the following pages. Make sure when installing bulbs, that the guide pin on the socket fits into its corresponding recess. When installing bulbs, do not touch the glass with your fingers. The reason for this is that grease, oil or any other impurities can be carbonized onto the bulb and damage the reflector. Use bulbs of correct type and voltage. Failure to do so could activate the bulb failure warning light.



## Replacing sealed beam headlamp units

- 1 Press the two plastic screws down and turn them ¼ turn and remove them.
- 2 Lift up the rim slightly and remove it forwards.
- 3 Remove the Phillips screws and rim. Lift out the headlamp unit.
- 4 Disconnect the socket contact.

Installation is done by reversing the procedure.

**Check headlight alignment.**

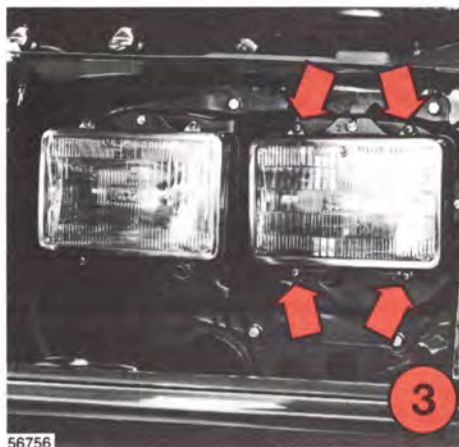



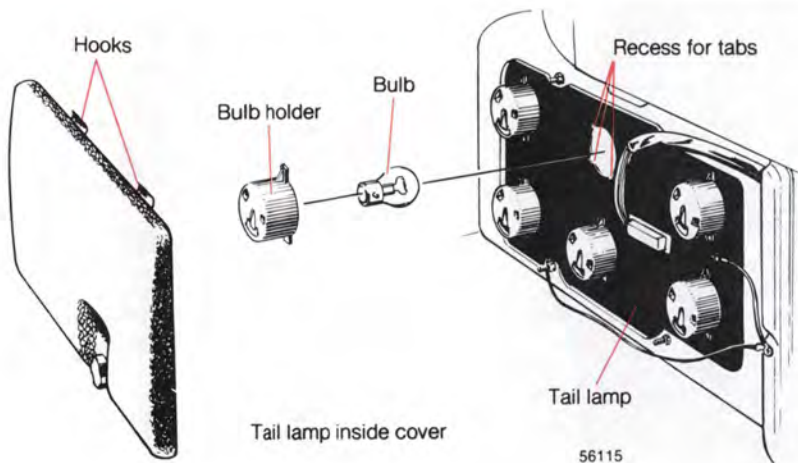

## Tail lamp bulbs 4 door model

All tail lamp bulbs are replaced from inside of trunk.

- 1 Unscrew and remove tail lamp inside cover. Note that inside cover is hooked at the upper edge. Lift the lower end out/up and unhook upper edge.
- 2 Turn bulb holder approx.  $\frac{3}{8}$ " counterclockwise and remove it.
- 3 Depress bulb in bulb holder, turn it slightly counterclockwise, and remove it.
- 4 Install a new bulb. Install bulb holder in tail lamp. NOTE: One of the bulb holder tabs is wider and fits only in corresponding recess. Turn bulb holder clockwise. Check that bulb lights. Replace tail lamp inside cover.

## Bulbs

- 1 Stop light
- 2 Back up light
- 3 Rear turn signal
- 4 Tail light
- 5 Reflector
- 6 Tail light

Power CP(W)	Socket	US Bulb No
32(21)	Ba 15s	1073
32(21)	Ba 15s	1073
32(21)	Ba 15s	1073
4( 5)	Ba 15s	67
—	—	—
4( 5)	Ba 15s	67

# Replacing bulbs



56753

## Front light bulbs

Loosen the Phillips screws and remove the lens. The bulbs can now be removed by pressing them inwards and turning them slightly counterclockwise.

When re-installing lens, check that the gasket is in position.

Bulbs	Power CP(W)	Socket
1 Front position Side marker lights	4( 5)	Ba 15s <sup>1)</sup>
2 Front turn signal	32(21)	Ba 15s <sup>2)</sup>

- 1) US Bulb No 67
- 2) US Bulb No 1073



56417

## Tail lamp bulbs, wagon model

All bulbs in the tail light cluster are removed from the inside.

Changing bulb, left hand side:

- Remove the spare tire cover and the spare wheel.

Changing bulb, right hand side:

- Remove the right hand stowage cover.
- Loosen the clip and move panel aside (see illustration).

The procedure for changing a bulb is basically the same as for other models.

When re-installing, hold the bulb holder with the word "Volvo" turned towards the center of the car.

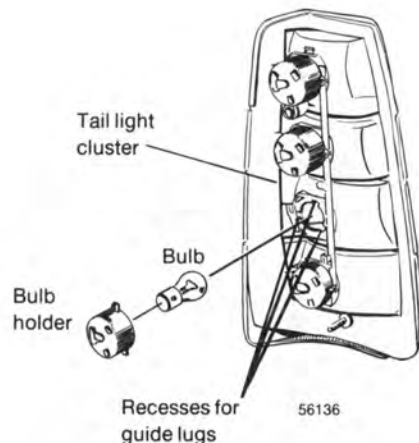

### Bulbs

- 1 Stop light
- 2 Back-up light
- 3 Rear turn signal
- 4 Tail light

- 1) US Bulb No 67
- 2) US Bulb No 1073

### Power

- CP(W)
- 32(21)
  - 32(21)
  - 32(21)
  - 4( 5)

### Socket

- Ba 15s<sup>2)</sup>
- Ba 15s<sup>2)</sup>
- Ba 15s<sup>2)</sup>
- Ba 15s<sup>1)</sup>



56402

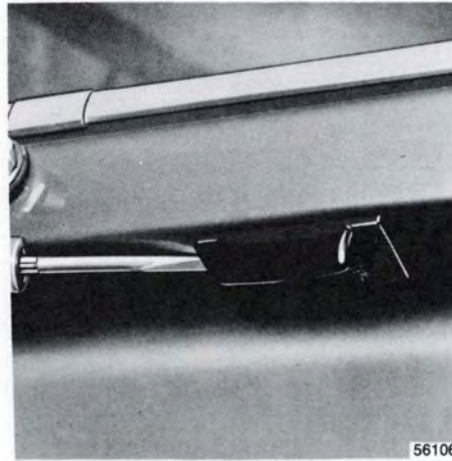

56106

## License plate light

Slide the bulb housing backwards until it is released from the front edge. Pull out the lamp housing and replace the bulb. Insert the front edge of the lamp housing and press up the rear edge by hand.

Bulbs	Power	Socket
License plate light,	4 W	Ba 9 s

## License plate light, wagon model

Insert a screwdriver through the opening in the housing and depress the catch tab. Pull out the housing assembly.

Bulbs	Power	Socket
License plate light, wagon	5 W	S 8.5—8



# Replacing bulbs

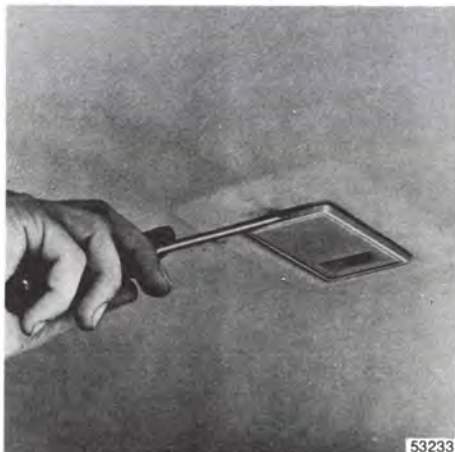

## Interior light

Insert a screwdriver through the opening in the right side of the housing and depress the catch tab. Pull out the housing assembly and replace the bulb.

Bulb	Power	Socket
Interior light	10 W	S 8.5—8

## Engine compartment light (optional on some models), Trunk light

Remove screw holding the light assembly. Lift it out to remove.

Replace the bulb.

Reinstall by first inserting the guides into one side, then press in the light assembly and install the screw.

Bulb	Power	Socket
Engine compartment light	15 W	S 8.5—8
Trunk light	15 W	S 8.5—8

## Instrument and heater control lighting

Due to the location of the bulbs, their replacement should be carried out by a Volvo dealer.

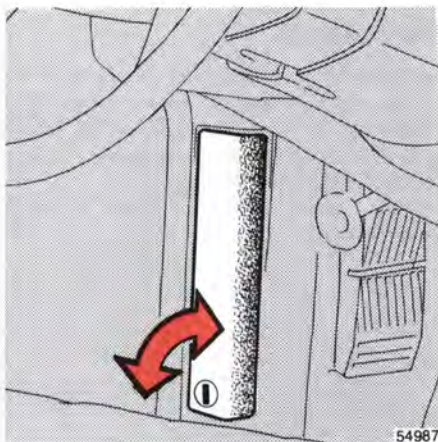

54987

## Replacing fuses

The fuse box is positioned in front of the left front door pillar.

When replacing fuses, check that right amperage is used.

**Never** use fuses of higher amperage. If one fuse repeatedly fails, take the car to your Volvo dealer for fault-tracing.

### WARNING:

Turn starting (ignition) switch OFF before replacing fuses. Excessive heat may be created by a short circuit. Care must be exercised while replacing blown fuses.



54969

1 Cigarette lighter, El. operated side mirrors (optional), Radio (optional) .....	8 A
2 Window wiper/washer, Horn, Tailgate wiper/washer .....	16 A
3 Heater blower .....	25 A
4 Seat belt warning, Ignition key chime .....	8 A
5 Fuel feed pump .....	8 A
6 Brake light, Relay, interior light .....	8 A
7 Main fuel pump, CI-system .....	16 A
8 Interior light, Glove box light, Clock, Trunk light, Engine compartment light, Central locking, El. radio antenna (optional), Electrically operated trunk lock .....	8 A
9 Hazard warning flashers .....	8 A
10 Window lifts .....	16 A
11 Overdrive (manual and automatic gearbox), El. heated rear window .....	16 A
12 Back-up lights, Relay, window lifts, Heated driver's seat, Air conditioning, Heater fan, Relay rear window demister .....	8 A
13 Instruments, Turn signals, Seat belt warning light, Relay fuel injection CI-system, Control unit LH-Jetronic system, Constant idle System, Relay electric cooling fan, solenoid valve, carburetor .....	8 A
14 Spare	
15 Parking light, left side, License plate light ..	8 A
16 Parking light, right side, Light on instruments and controls, Headlights chime .....	8 A
17 Fuse storage, spare	
In engine compartment: Engine control system (LH-Jetronic system) located in the engine compartment on the left wheel housing by the ignition coil (blade type fuse) .....	25 A

# Wheels and tires

## Checking and correcting tire pressure

Check the tire pressure when refueling. The tire pressure should only be corrected when the tires are cold. With warm tires, correct only when the pressure is too low. The tire temperature rises after driving just a few miles.

### WARNING!

**Improperly inflated tires will reduce tire life, adversely affect vehicle handling and can possibly lead to failure resulting in loss of vehicle control without prior warning.**

## Vehicle Loading

The tires on your Volvo will perform to specifications at all normal loads when inflated as recommended on the tire information label located on the rear facing side of the right front door. This label lists both tire and vehicle design limits.

Do not load your car beyond the load limits indicated.

## Tire Pressure Label

The tire pressure label is located on the rear facing side of the right front door.

See section titled "Specifications" and Consumer Information Booklet for complete tire pressure information.

## Wear Indicator

The tires have a so-called "wear indicator" in the form of a number of narrow strips running across or parallel to the tread. When approx.  $\frac{1}{16}$ " = 1.5 mm is left on the tread, these strips show up and indicate the tire should be replaced.

Tires with less than  $\frac{1}{16}$ " tread have a very poor grip in rain or snow.

## Examples of tire wear

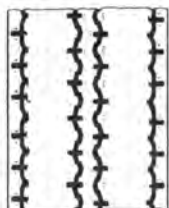

54981/1

Underinflated

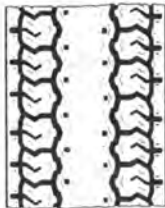

54981/2

Overinflated

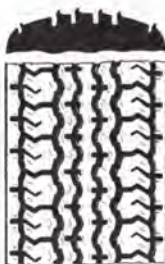

54982/1

Wrong toe-in



54983/1

Unbalance

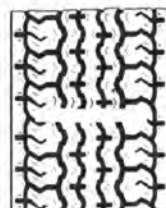

54983/2

Wear indicator exposed  
Tire is worn, replace



## General

When replacing worn tires, it is recommended that the tire be similar in type (radial) and size as the one being replaced. Using a tire of the same make (manufacturer) will prevent altering the driving characteristics of the vehicle.

## How to improve tire economy

- Maintain correct tire pressure.
- Drive smoothly: avoid fast starts, hard braking and tire screeching.
- Tire wear increases with speed.
- Do not change wheel location unless necessary.
- Correct front wheel alignment is very important.
- Unbalanced wheels impair tire economy and driving comfort.
- Hitting curbs can damage the tires permanently.

## Winter Season

Radial snow tires, installed on all four wheels, are recommended for winter driving. Use tires that are comparable in size and type to the original equipment installed by the factory.

Mixing tires of different size, brand, or design could negatively affect tire road grip, especially when slippery road conditions exist.

For vehicles equipped with 195/60 R15 tires (Turbo), 185/65 R15 snow tires may be used. Alternatively, 185/70 R14 snow tires with 14" steel wheel rims may also be used.

**Note:** overall diameter of tire and wheel combination will affect speedometer accuracy and fuel economy.

Tire **chains** can be used on the rear wheels if the chains do not project too far from the tire and chafe against the brake caliper or other components.

**Strap-on emergency chains must not be used since the space between the brake caliper and the wheel rim is inadequate.**

## Special Spare

The spare wheel for your car is referred to as a "Special Spare". This name is embossed on the tire.

On 2 and 4-door models, the "Special Spare" wheel contains a 6 ply rating tire and on the wagon models an 8 ply rating tire.

Tire pressure must be 36 psi (250 kPa) on a 6 ply rating tire and 40 psi (280 kPa) on a 8 ply rating tire irrespective of load or where the wheel is installed.

In the event of a damage to this tire a new one can be purchased from your Volvo dealer.

## WARNING!

Current legislation prohibits the use of this tire other than as a temporary replacement for a punctured tire. In other words, it must be replaced as soon as possible by a standard tire.

Roadholding, etc., might be affected with the "Special Spare" in use. Do not therefore exceed 50 mph (80 km/h).

## WARNING!

### Air dam (front spoiler)

Air dams can negatively influence the normal flow of air to the front wheel brakes. Therefore, special light alloy wheel rims must be used in conjunction with the air dam. Steel wheel rims of 1980 or later year models together with ventilated brake disks can be used in place of light alloy wheels.

### Special wheel rims

Only special wheel rims, tested and approved by Volvo, are suitable for use with air dams.

## Wheel changing

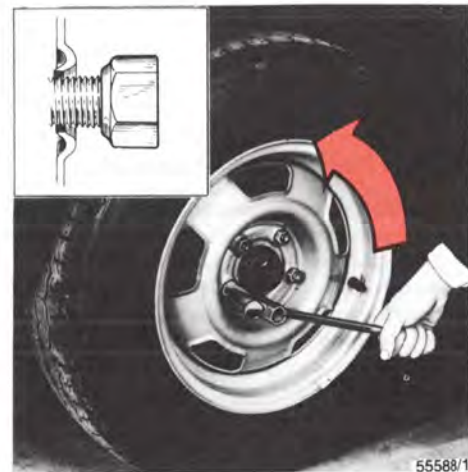
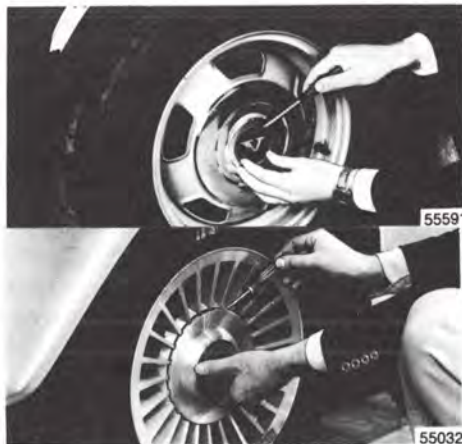

### Changing a wheel

Spare wheel, jack and tool kit are stowed in the trunk compartment. On the 5 door models the jack and crank should be secured according to the above illustration to avoid any disturbing rattles. Make sure that the spare wheel is secured. Before raising the car with the jack be sure it is on firm and level ground.

**Note:** Do not crawl or work under the car while it is raised by the jack.

Before the car is raised with the jack the parking brake should be applied and one of the gears engaged. With automatic transmission, the selector should be in **Park**. Block one of the wheels on the opposite side of the car from the jack.

**Note:** To avoid excessive tire wear and rebalancing, mark and reinstall wheels in same location and position as before removal.

### Removal

To remove the wheel cap the center emblem must first be pried-off using the screwdriver provided in the tool kit. The wheel cap may then be removed by hand. The Turbo has no wheel cap: Loosen the wheel nuts  $\frac{1}{2}$ -1 turn with the box wrench provided in the tool kit. All of the wheel nuts have right-hand threads which are loosened by turning them counterclockwise.

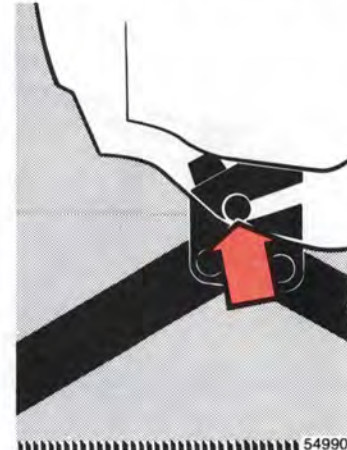
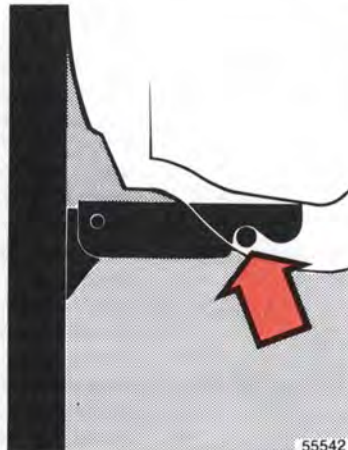

Insert the lifting arm of the jack in the jack attachment closest to the wheel to be changed.

**Be sure the arm goes all the way into the attachment.**

**5 door model:** Hang the jack from the attachment and crank the jack base down guiding it securely against the ground. Before raising the car check again to be sure that the jack is correctly positioned in the attachment.

Raise up the side of the car enough to lift the wheel off the ground.

Unscrew the wheel nuts completely and remove the wheel carefully so as not to damage the threads of the studs.

## Installation

- Clean the nuts and the contact surface between wheel and hub.
- Lift on the wheel and fit the wheel center on the hub shoulder.
- Tighten the nuts until the wheel makes good contact with the flange.
- Lower the car and tighten the nuts alternately to 72-100 ft.lbs. (100-130 Nm). The bevelled side of the nuts should face the wheel.
- Fit the wheel cap.

**NOTE:** Do not rotate a raised rear wheel if the car is equipped with a limited slip differential. This will also move the opposite wheel on the ground and the car may slide off the jack.

## WARNING!

- Be sure the jack is on firm and level ground.
- Never crawl under a car supported by a jack.
- Use the jack intended for the car when replacing a wheel. For any other job use stands to support the end of the car being worked on.
- Apply the parking brake, engage first or reverse gear (pos. P for cars equipped with automatic transmission).
- Block the wheels standing on the ground. Use rigid wooden blocks or large stones.
- The jack should be kept well-greased.



# Replacing wiper blades, washing

## Replacing wiper blades



Lift the wiper arm off the windshield and hold blade at right angles to arm. Pinch the end of the plastic clip located at the back of the arm.



Slide the wiper blade along the arm to release it from the hook.



Install new blade in reverse order to removing and make sure that it is properly attached to the wiper arm.

For reasons of safety, you should change the windshield wiper blades as soon as they start to leave marks on the windshield or fail to wipe efficiently and cleanly.

57076

## Washing

The car should be washed at regular intervals since dirt, dust, insects and tar spots adhere to the paint and may cause damage.

When washing the car, do not expose it to direct sunlight. Use lukewarm water to soften the dirt before you wash with a sponge, and plenty of water, to avoid scratching.

A detergent can be used to facilitate the softening of dirt and oil.

Special car washing detergent or household detergent can be used. A suitable mixture is about 2.5 fl. oz. (8.5 cl) of detergent to 2.6 US gal. = 10 liters of warm water. After washing with a detergent the car should be well rinsed with clean water.

A water soluble grease solvent may be used in cases of sticky dirt. However, use a washplace equipped with a drainage separator.

Dry the car with a clean chamois and remember to clean the drain holes in the doors and rocker panels.

Tar spots can be removed with kerosene or tar remover after the car has been washed.

Electrically operated antenna (optional) should be dried and lightly lubricated with an oil dampened cloth.

**NOTE:** It is particularly important to wash the car frequently in the winter time, to prevent corrosion, when salt has been used on the roads. Also wash off the dirt on the underside (Wheel housings and fenders etc).

**NOTE:** When the car is driven immediately after being washed, apply the brakes now and again in order to remove any moisture from the brake linings.

## Machine washing

Hand washing of car is superior to machine washing. We recommend that you do not wash your car in an automatic wash during the first six months (because the paint will not have hardened sufficiently).

If automatic car washing is essential use only reputable establishments with non-synthetic brushes. Synthetic brushes may cause the paints top surface to be scratched.

## Bird droppings

Remove from paintwork as soon as possible. Otherwise the finish may be permanently damaged.

## Chromed parts

Chromium-plated and anodized parts should be washed with clean water as soon as they become dirty. This is particularly important if you drive on gravel roads or on roads where salt is used during the winter. After the car has been washed, apply wax or an anti-rust preparation.

Stains on chrome trim can be removed with commercially available chrome cleaner. Do not use abrasive compounds or steel wool.

## Polishing (waxing)

Polishing and waxing is not necessary unless a glossy surface can no longer be obtained by normal car washing. Normally, polishing is not required during the first year after delivery, however, waxing may be beneficial.

Before applying polish or wax the car must be washed and dried. Tar spots can be removed with kerosene or tar remover. Difficult spots may require a fine rubbing compound.

After polishing use liquid or paste wax.

Several commercially available products contain both polish and wax. Waxing alone does not substitute for polishing of a dull surface.

A wide range of polymer based car waxes can be purchased today. The waxes are easy to use and produce a long lasting high gloss finish which protects the bodywork against oxidation, road dirt and fading.

## Cleaning the upholstery

Generally the **fabric** can be cleaned with soapy water or a detergent. For more difficult spots caused by oil, ice cream, shoe polish, grease, etc., use a stain remover.

The **plastic** in the upholstery can be washed.

To clean **leather upholstery**, use soft cloth and mild soap solution, for instance common bath soap.

For more difficult spots, consult an expert for the choice of cleaning agent.

**On no account must gasoline, naphtha or similar cleaning agents be used on the plastic or the leather since these can cause damage.**

When aging, leather changes appearance, but the typical texture remains. To preserve smoothness and appearance, it is recommended to treat the leather with a special leather preservative after one or two years of use.

## Cleaning the seat belts

Clean only with luke warm water and mild soap solution.

## Cleaning floor mats

The floor mats should be vacuumed or brushed clean regularly, especially during the winter when they should be taken out for drying. Spots on textile mats can be removed with a mild detergent.

## Anti-rust treatment

Your Volvo has been rust protected at the factory. On external surfaces a heavy coat of wear resistant material has been used, while on the internal surfaces a lighter rust protector is used.

The external rust protection should be inspected regularly or at least once per year.

If the rust protection has been penetrated a repair should be made as soon as possible to prevent moisture from entering between the metal and coating. Carefully clean and remove any rust prior to repair of the rust protective coating.

The internal rust protection should normally be renewed first time after 36 months and then at least every 24th month.

For further information, see section titled "What causes rust" or see your Volvo dealer.

# Paint touch-up

## Paint touch-up

Paint damage requires immediate attention to avoid rusting. Make it a habit to check the finish regularly, for instance when washing the car. Touch-up if necessary.

Paint repairs require special equipment and skill. Contact your Volvo dealer for any extensive damages.

Minor scratches can be repaired by using Volvo touch-up paint.

NOTE: When ordering touch-up paint from your Volvo dealer, use the paint code indicated on the service label. The label is located on the wheel housing in the engine compartment.

Paint code

VOLVO		MADE IN
	kg	
	kg	
1-	kg	
2-	kg	

56117

## Minor stone chips and scratches

Material:

Rust remover

Primer — brush—on type

Surface finish — brush—on type

Penknife or similar

Brush

NOTE: When touching-up the car, it should be well cleaned and dry and have a surface temperature above 60°F (+15°C).

**Scars on the surface** (where the paint has not been completely penetrated). Repairs can be made directly after light scraping to remove dirt.

**Deep scars,** (down to the bare metal):

- 1 Scrape or sand the damaged surface lightly and break the edges of the scar.

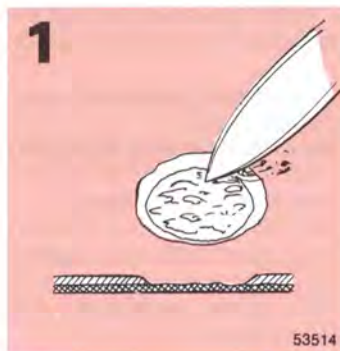

Apply the rust remover. (Avoid contact with eyes and skin!) Wait a few minutes and then rinse carefully with water and wipe dry.

- 2 Thoroughly mix the primer and apply it with a small brush.



When the primer surface is dry, the paint can be applied using a brush.

Mix the paint thoroughly, apply several thin paint coats and let dry after each application.



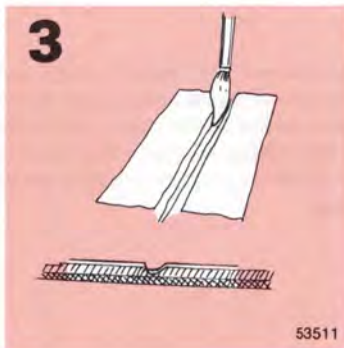

## Touching-up damaged paint on fender edges and sills

Material:  
 Rust remover  
 Primer — spray  
 Surface finish — spray  
 Sand paper (H 150 — 300 grit)  
 Thinner

NOTE! When touching-up the car, it should be well cleaned and dry and have a temperature exceeding 60° F (+15° C).

Mask with tape and paper prior to painting larger surfaces. Remove the masking immediately after application of the last paint coat, before the paint starts to dry.

Touching-up is as follows:

- 1 Remove paint flakes.
- 2 Sand the damaged surface and wash it clean with thinner.  
 Apply the rust remover. (Avoid contact with skin!) Wait a few minutes and then rinse carefully with water and wipe dry.

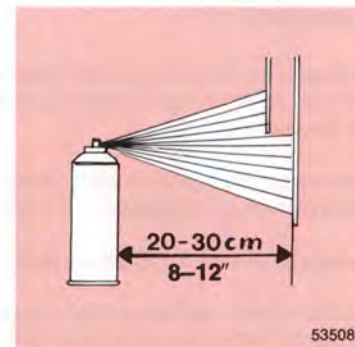

- 3 If there is a longer scratch, you may want to mask to protect surrounding paint.

- 3 Shake the spray can for at least 1 minute. Spray on the primer. Move the can slowly and evenly back and forth over the spot and about 8 — 12 in. (20 — 30 cm) from the surface. Protect the surrounding surfaces with suitable paper.  
 NOTE! Spray painting should be done in a well ventilated and dust-free area.
- 4 When the primer has dried, apply the surface enamel in the same way. Spray on several times and allow the paint to dry a minute or so between each application.

# What causes rust

---

## What causes rust

### The two most common causes of rust to your car are:

1. The accumulation of road dirt and moisture in hard-to-get-at cavities and other areas under the car:
2. The removal of paint and protective coatings on the outside of the car and underneath through damage by stones, gravel or minor accidents.

### Several factors influence the speed at which corrosion will occur:

1. The length of time various parts of a car stay wet. Parts of the car filled with road dirt and water remain damp for long periods of time even when other parts are dry.  
Particular attention should be paid to the underside of the car and floor sections inside. The floor sections stay wet because moisture collects and remains under the floor matting.  
Drain holes located at the bottom of the doors get clogged with dirt, trapping water inside the door and causing the door to rust through at the bottom.
2. Corrosion will be accelerated in areas of higher relative humidity, especially where temperatures often stay above the freezing point and where the atmosphere is affected by industrial pollution, or where salt is used for de-icing the roads.  
Where parts of the car are covered with road dirt containing road salt, corrosion will be accelerated at a lower relative humidity than if the surface were clean.
3. Increased temperature will cause an accelerated rate of corrosion of those parts of the car which are not well ventilated to permit quick drying.
4. Industrial pollution and the presence of salt will also accelerate the deterioration of paint finishes.

The foregoing identifies the need for every car owner to keep his car and particularly the underside, as clean and dry as possible and to repair any minor damage to paint work and protective coating as soon as possible. The need is more important in those localities where road salt is used for de-icing, the relative humidity is higher, air pollution is present and temperatures regularly stay above freezing.

## Prior to a long distance trip

Have your car checked at a Volvo dealer. Preventive maintenance will help to ensure a trouble free trip. Remember to take along a Volvo dealer directory.

The main items to check are listed below:

1. Brakes, front wheel alignment and steering gear.
2. Engine running condition.
3. Fuel system operation.
4. Oil leaks: engine, transmission, rear axle.
5. Cooling system for leaks or worn hoses.
6. Examine tires carefully, replace worn tires.
7. Battery and terminals.
8. Tool equipment.
9. Lighting.
10. Drive belts, for tightness and wear.
11. All fluid levels.

## Cold weather

### Anti-freeze for door locks

Lubricate the outside locks with a suitable anti-freeze. Such agents are commercially available and should be used before the first frost.

### Engine fuel system

During the winter, large variations in temperature causes condensation to form in the fuel tank and can impair the running of the engine. This can be eliminated by adding special additives to the fuel. There is less risk of condensation forming in the fuel tank if it is kept full.

### Engine cooling system

Volvo type C (blue-green) coolant should be used all the year round. The cooling system should always contain water plus anti-freeze and rust inhibitor, even during the summer. Experience has also shown that extremely weak anti-freeze solutions (10-25 percent) are ineffective for rust protection. For this reason, the quantity of anti-freeze/summer coolant should amount to about 50 percent of the solution, that is 5.0 US qts. = 4.8 liters. This lowers the freezing point to  $-30^{\circ}\text{F}$  ( $-35^{\circ}\text{C}$ ).

Alcohol must not be used as an anti-freeze agent since it evaporates at normal engine temperature.

### Engine lubricating system

During the winter, multigrade oil 10W-30 should be used in the engine. At very low temperatures, below  $0^{\circ}\text{F}$  ( $-20^{\circ}\text{C}$ ), multigrade oil SAE 5W-30 is recommended. These oils reach the lubricating points in the engine more easily at low temperature and also facilitate cold starting. See section titled "Engine Oil".

### Electrical system

The electrical system is subject to great stresses during the winter. Lighting and starter motor are used more often. The battery capacity is impaired at low air temperature. The state of charge must be checked more frequently, and if necessary the battery should be recharged. The battery may freeze if the state of charge is low.

### Windshield washers

Anti-freeze should also be added to the water container for the windshield and rear window (tailgate, wagon model) washer.

This is particularly important during the winter because the windshield frequently becomes dirty and is often splashed with water which rapidly freezes. This may necessitate the frequent use of the windshield washer and wipers. Your Volvo dealer can supply you with suitable anti-freeze for this purpose. Suitable mixtures of anti-freeze and water are:

Down to  $+14^{\circ}\text{F}$  ( $-10^{\circ}\text{C}$ ) 1 part anti-freeze 4 parts water.

Down to  $+7^{\circ}\text{F}$  ( $-14^{\circ}\text{C}$ ) 1 part anti-freeze 3 parts water.

Down to  $0^{\circ}\text{F}$  ( $-18^{\circ}\text{C}$ ) 1 part anti-freeze 2 parts water.

Down to  $-18^{\circ}\text{F}$  ( $-28^{\circ}\text{C}$ ) 1 part anti-freeze 1 part water.

### Brake system

During cold weather the brakes are subject to splash and condensation which can result in the parking brake freezing up, especially if applied for long periods of time. Use of first or reverse gear on a manual transmission or position "P" on an automatic transmission is preferable during these conditions. See section titled "Brake System".



## Service diagnosis

---

The diagnosis outlined below is only intended to serve as a guide to locate and temporarily correct minor faults. Causes for unsatisfactory performance should be investigated and corrected by your Volvo dealer.

NOTE: The points indicated by an asterisk (\*) should be checked by your Volvo dealer.

### Condition: Starter fails to operate (or operates very slowly)

---

Possible cause	Correction
Weak battery or dead cell.	With the starting (ignition) switch in the "Driving" or "On" position, check to see if the warning lights on the dashboard come on and if they stay on when the starter is engaged. If the lights do not come on or if they go off when the starter is engaged, the battery is discharged or see below.
Loose or corroded battery cable terminals.	Check battery terminals and clamps. Clean or replace if necessary. Check that the starter cable is secure at its terminals. The ground strap, which connects the body to the rear of the engine, should also be checked for corrosion or looseness.
Open circuit between starting (ignition) switch and starting (ignition) switch terminal on starter.	The circuit is closed if a clicking sound is heard from the starter when it is engaged. If no clicking sound is heard, check that the blue wire at the starter is secure. If still no clicking sound is heard, the starting (ignition) switch or the wire is defective.
Starter motor defective.	If the above checks have been performed, and no fault is evident, the starter may be defective. NOTE: In this case the headlight intensity will not dim when the starter is engaged

## Condition: Starter motor operates but engine does not start

Possible cause	Correction
Intake system leaking.	Check vacuum hose connections at manifold and auxiliary air valve.
No fuel reaching engine.	Check for fuel in the tank. Check fuses No 5, 7 and 13
No spark	Check that the high tension lead from the coil to the distributor cap is connected and that the wires to the distributor and coil are connected. Check the fuse for the engine control system (certain models). The fuse is located in the engine compartment on the left wheel housing by the ignition coil.
Spark plugs, high tension leads or distributor cap wet or defective.	Clean the parts with a dry cloth or spray with a moisture remover. Replace defective or worn parts.
Cold start injector defective. (B21FT)	Test the cold start injector function with cold and hot engine.*
Rest pressure incorrect. (except B21A)	Test rest pressure and the fuel system for leaks.* If no fault is found following the above steps, contact your Volvo dealer.

\*Should be checked by a Volvo dealer.

## Service diagnosis

### Condition: Erratic idle (misfiring)

Possible cause	Correction
Intake system leaking.	Check hose connections.
Spark plugs, high tension leads or distributor cap worn (defective)	Clean distributor cap and leads, check the cap for cracks. Replace defective or worn parts.
Worn spark plugs.	Remove. Clean or replace spark plugs.
Cold start injector leaking. (B21FT)	Test the injector function.*
Uneven compression.	Test compression.*

### Condition: Engine stalls at irregular intervals

Possible cause	Correction
Defective wires.	Check wire terminals at: fuel pump, fuse No. 5 and 7, coil, distributor, ignition switch and relays.
Intake system leaking.	Check vacuum hose connections at manifold and auxiliary air valve.
Low idle speed. (B21A)	Adjust.*
Fuel filter clogged.	Clean fuel tank filter and replace line fuel filter.

\*Should be checked by a Volvo dealer.



## Condition: Low top speed, loss of power

Possible cause	Correction
Air filter clogged.	Check air filter.*
Throttle misadjusted.	Check that the throttle touches the high speed stop when the accelerator is fully depressed.*
Incorrect timing.	Check and adjust.*
Fuel filter clogged.	Clean fuel tank filter and replace fuel line filter.*
LH-Jetronic system in "limp-home" mode	Replace the air-flow sensor*

## Condition: Excessive fuel consumption

Possible cause	Correction
Fuel lines leaking.	Check tightness.
Spark plugs worn.	Replace plugs.
Incorrect timing.	Check / adjust.*
Air filter clogged.	Check / replace.*
Control pressure incorrect.	Check / replace control pressure regulator.*
Cold start injector leaking.	Replace injector.* (A leaking cold start injector also causes uneven idle and hard starting.)

\*Should be checked by a Volvo dealer.

# Service diagnosis

---

## Condition: Dieseling

Possible cause	Correction
Injector leaking.	Check air flow sensor plate and rest pressure.*

## Condition: Misfiring at highway driving speed

Possible cause	Correction
Spark plugs fouled.	Drive the vehicle in a lower gear and keep the engine rpm higher for a few miles in order to remove carbon deposit on the spark plugs. If this procedure is not effective, clean or replace the spark plugs.

\*Should be checked by a Volvo dealer.

The VIN number should always be quoted in all correspondence concerning your vehicle with the dealer and when ordering parts.

## 1 Vehicle Identification Number (VIN)

VIN plate is located on top left surface of dash. The VIN is also stamped on the right hand door pillar.

## 2 Vehicle Emission Control Information

Your Volvo is designed to meet all applicable safety and emissions standards. Evidence of this can be verified from the certification label on the left wheel valance. For further information regarding these regulations, please consult your Volvo dealer.

## 3 Model Plate

Vehicle Identification Number (VIN). Codes for color and upholstery etc. This plate is located on right wheel valance.

## 4 Loads and Tire Pressures

## 5 Federal Motor Vehicle Safety Standards (FMVSS) specifications (USA) and Ministry of Transport (CMVSS) Standards (Canada)

This label is located on rear facing side of the driver's front door.

## 6 Service Label

Label under rear window trunk lid on right hand side (Sedan) or on right hand side of the large storage space (Wagon).

Information on certain components.

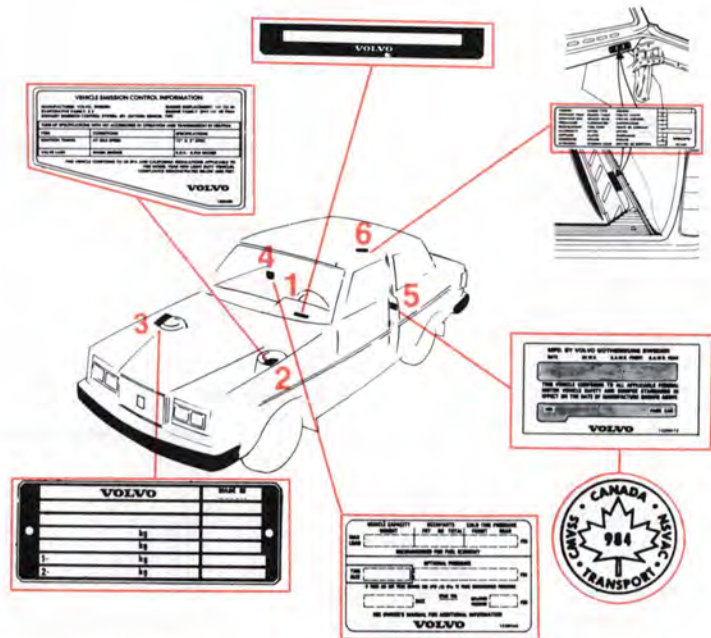

56469



# Specifications

## Dimensions and weights

	2 door models	4 door models	Wagon models (except Turbo)	Turbo wagon
Length	189.4" (481 cm)	189.4" (481 cm)	189.4" (481 cm)	189.4" (481 cm)
Width	67.3" (171 cm)	67.3" (171 cm)	67.3" (171 cm)	67.3" (171 cm)
Height, curb weight	56.3" (143 cm)	56.3" (143 cm)	57.5" (146 cm)	57.5" (146 cm)
Wheelbase	104.3" (265 cm)	104.3" (265 cm)	104.3" (265 cm)	104.3" (265 cm)
Ground clearance (full load)	4.7" (12 cm)	4.7" (12 cm)	4.7" (12 cm)	4.7" (12 cm)
Track, front	56.3" (143 cm)	56.3" (143 cm)	56.3" (143 cm)	56.3" (143 cm)
rear	53.5" (136 cm)	53.5" (136 cm)	53.5" (136 cm)	53.5" (136 cm)
Turning circle (between curbs)	32.2' (9.8 m)	32.2' (9.8 m)	32.2' (9.8 m)	32.2' (9.8 m)
Curb weight (depending on type)	2879-3003 lbs (1308-1365 kg)	2910-3047 lbs (1322-1385 kg)	3047-3064 lbs (1385-1393 kg)	3144-3155 lbs (1429-1434 kg)
Gross vehicle weight (GVW)	4030 lbs (1830 kg)	4030 lbs (1830 kg)	4300 lbs (1950 kg)	4190 lbs (1900 kg)
Capacity weight	980 lbs (445 kg)	960 lbs (435 kg)	1220 lbs (555 kg)	970 lbs (440 kg)
Permissible axle weight, front	1885 lbs (855 kg)	1885 lbs (855 kg)	1885 lbs (855 kg)	1885 lbs (855 kg)
rear	2180 lbs (990 kg)	2180 lbs (990 kg)	2600 lbs (1180 kg)	2340 lbs (1060 kg)
Max. trailer weight (trailer equipped with service brakes)	3300 lbs (1500 kg)	3300 lbs (1500 kg)	3300 lbs (1500 kg)	3300 lbs (1500 kg)
Max. hitch load	200 lbs (90 kg)	200 lbs (90 kg)	200 lbs (90 kg)	200 lbs (90 kg)

## Cargo Space

	Wagon models
Length with rear seat up	44.5" (113 cm)
Length with rear seat down	74.0" (188 cm)
Maximum width	53.1" (135 cm)
Height	32.9" (84 cm)
Volume with rear seat up	41 cu. ' (1.2 m <sup>3</sup> )
Volume with rear seat down	71 cu. ' (2.0 m <sup>3</sup> )
Cargo opening, maximum width	45.7" (116 cm)
Cargo opening, maximum height	30.7" (78 cm)

**NOTE:** When adding accessories, equipment, luggage and other cargo to your vehicle, the total loaded weight capacity of the vehicle must not be exceeded. Consult your dealer for information.

## Dimensions and weights for Canadian models

	2 door	4 door	Wagon	Turbo wagon
Length	192" (489 cm)	192" (489 cm)	192" (489 cm)	192" (489 cm)
Curb weight (depending on type)	2970-2981 lbs (1347-1352 kg)	2855-3025 lbs (1295-1372 kg)	2976-2992 lbs (1350-1357 kg)	3122-3133 lbs (1416-1421 kg)
Gross vehicle weight	4030 lbs (1830 kg)	4030 lbs (1830 kg)	4190 lbs (1900 kg)	4190 lbs (1900 kg)
Capacity weight	960 lbs (435 kg)	940 lbs (425 kg)	1090 lbs (495 kg)	950 lbs (430 kg)
Permissible axle weight, rear	2180 lbs (990 kg)	2180 lbs (990 kg)	2470 lbs (1120 kg)	2340 lbs (1060 kg)

## ENGINE

4-cylinder in-line liquid-cooled gasoline engine. Cylinder block in special cast iron. Cylinders are bored directly in block.

Cylinder head in light-alloy. Separate inlet and exhaust passages. Single, overhead camshaft.

Engine lubrication is provided by a gear pump driven from crankshaft. Full-flow type oil filter. Exhaust emission control accomplished by fuel injection. Exhaust Gas Recirculation (some models also equipped with Lambda-sond® system and 3-way catalytic converter). Closed crankcase ventilation system and evaporative emission control system.

Type designation	B 21 F Turbo	B 23 F (automatic)	B 23 F (manual)
Output (SAE J 1349) at/rpm	131 hp/5400	114 hp/5400	111 hp/5400
Max torque (SAE J 1349) at/rpm	155 ft. lbs./3750	133 ft. lbs./3500	136 ft. lbs./2750
Number of cylinders	4	4	4
Bore	3.62" (92 mm)	3.78" (96 mm)	3.78" (96 mm)
Stroke	3.15" (80 mm)	3.15" (80 mm)	3.15" (80 mm)
Displacement	2.13 liters	2.32 liters	2.32 liters
Compression ratio	7.5	10.3	9.5
Valves	overhead	overhead	overhead
Valve clearance, inlet and exhaust engine at normal operating temp.		0.014–0.18" (0.35–0.45 mm) when checking 0.016–0.18" (0.40–0.45 mm) when adjusting	
Firing order	1-3-4-2	1-3-4-2	1-3-4-2
Ignition setting, vacuum regulator disconnected	12° ± 2° BTDC at idle		12° ± 1° BTDC at idle (vacuum connected)
Spark plugs	Volvo Part No. 273594-2 (Bosch WR7DS)		Volvo Part No. 273594-2 (Bosch WR7DS)
Spark plug gap	0.7-0.8 mm (0.028-0.032")		0.7-0.8 mm (0.028-0.032")
Tightening torque	15-22 ft. lbs. (20-30 Nm)		15-22 ft. lbs. (20-30 Nm)
Distributor, direction of rotation	Clockwise		Clockwise

# Specifications

---

## Type designation

Output (SAE J 1349) at /rpm  
Max torque (SAE J 1349) at /rpm  
Number of cylinders  
Bore  
Stroke  
Displacement  
Compression ratio  
Valves  
Valve clearance, inlet and  
exhaust engine at normal  
operating temp.  
Firing order  
Ignition setting,  
vacuum regulator disconnected  
Spark plugs  
  
Spark plug gap  
Tightening torque  
Distributor, direction of rotation

## B21 A (Canada)

105 hp / 5250  
127 ft. lbs. / 2500  
4  
3.62" (92 mm)  
3.15" (80 mm)  
2.13 liters  
9.3  
overhead  
0.014–0.18" (0.35–0.45 mm) when checking  
0.016–0.18" (0.40–0.45 mm) when adjusting  
  
1-3-4-2  
  
 $7^{\circ} \pm 2^{\circ}$  BTDC at  $750 \pm 50$  rpm  
Volvo Part No. 273597-5  
(Bosch W7DC)  
0.7-0.8 mm (0.028-0.032")  
15-22 ft. lbs. (20-30 Nm)  
Clockwise

## Cooling System

**Type:** Positive pressure

**Thermostat begins to open at:** 197° F (92° C)

**Fan belts, designation:** HC—38 × 925

**Coolant:** Volvo Coolant Type C (blue-green)

## Fuel System

**B21 F Turbo:** Fuel injection  
CI-system

**B23 F:** L.H. Jetronic

**B21 A:** Carburetor Zenith

## Capacities

Fuel tank	15.8 US gals. = 60 liters.
Cooling system	9.9 US qts. = 9.4 liters. (of which expansion tank = 0.7 US qts(0.6 liter)

### Oil capacity:

Cars without turbo engine, oil change	3.5 US qts. = 3.35 liters.
incl. oil filter	4.0 US qts. = 3.85 liters.

### Cars with turbo.

Same as above except if oil cooler is drained add	0.7 US qts. = 0.6 liter
transmission (M 46)	2.4 US qts. = 2.3 liters.
auto. with overdrive	7.8 US qts. = 7.4 liters.
auto. without overdrive	7.1 US qts. = 6.7 liters.
rear axle	1.7 US qts. = 1.6 liters.
steering gear, power	0.8 US qts. = 0.75 liters.

## ELECTRICAL SYSTEM

12 V, negative ground.

Voltage-controlled alternator.

Single-wire system with chassis and engine used as conductors.

Voltage	12 V
Battery,	Volvo Part No. 1235272-0*
Capacity	60 Ah
Electrolyte, specific gravity	1.28
Recharge at	1.21
Alternator, rated output	840 W**
max. current	70 A**

\* or corresponding

\*\* B 21 F Turbo 770W, 55A

Lights, 12 V	US bulb No.	Power	Socket	No. of bulbs
Headlights, inner	H 4651	Sealed Beam	Halogen	2
Headlights, outer	H 4656	Sealed Beam	Halogen	2
Position Lights, front	67	5 W/4 cp	Ba 15 s	2
Turn Signals, front	1073	21 W/32 cp	Ba 15 s	2
Turn Signals, rear	1073	21 W/32 cp	Ba 15 s	2
Tail Lights	67	5 W/4 cp	Ba 15 s	4
Stop Lights	1073	21 W/32 cp	Ba 15 s	2
Back-up Lights	1073	21 W/32 cp	Ba 15 s	2

The following bulbs may be obtained from your nearest Volvo dealer:

Rear Ash Tray Light	1.2 W	W2x4.6d	1
License Plate Light, Sedan	4 W	Ba 9 s	2
License Plate Light, Wagon	5 W	S 8.5—8	2
Interior Light	10 W	S 8.5—8	1
Glove box Light	2 W	Ba 9 s	1
Instrument Panel Light	3 W	W2.1x9.5d	2
Control Panel Light	1.2 W	W2x4.6d	3
Shift Positions,			
Auto Transmission	1.2 W	W2x4.6d	1
Engine Compartment Light	15 W	S 8.5—8	1
Trunk light	15 W	S 8.5—8	1
Warning Lamps			
Charging	1.2 W	W2x4.6d	1
Turn Signals	1.2 W	W2x4.6d	2
Brake Failure	1.2 W	W2x4.6d	1
Parking Brake	1.2 W	W2x4.6d	1
Headlights	1.2 W	W2x4.6d	1
Oil Pressure	1.2 W	W2x4.6d	1
Overdrive	1.2 W	W2x4.6d	1
Warning Flashers	1.2 W	W2x4.6d	1
El. Heated Window	1.2 W	W2x4.6d	1
Lambda Sond® Reminder	1.2 W	W2x4.6d	1
Seat Belts	2 W	Ba 9 s	2
Bulb Failure	1.2 W	W2x4.6d	1
Choke	1.2 W	W2x4.6d	1
Boost Pressure (Turbo)	1.2 W	W2x4.6d	1



# Specifications

## FRONT END

Suspension is of the McPherson type with the shock absorber mounted in a strut in the coil spring.

Rack and pinion steering gear.

Power steering is standard on most models.

Safety steering column.

### Front wheel alignment

The alignment specifications apply to an unloaded car but include fuel, coolant and spare wheel.

Toe-in manual steering  $\frac{3}{16}$ " =  $0.11 \pm 0.04$ " ( $2.5 \pm 1$  mm)

(On rim) power steering  $\frac{1}{8}$ " =  $0.06 \pm 0.04$ " ( $1.5 \pm 1$  mm)

Caster (not to exceed  $\frac{1}{2}$ ° difference between sides)

—manual steering ..... +2° to +3°

—power steering ..... +3° to +4°

Camber (not to exceed  $\frac{1}{2}$ ° difference between sides)

—all, except Turbo ..... +1° to +1½°

—Turbo ..... +¼° to +¾°

(Reduce camber if excessive wear on tire outer shoulder is observed)

## POWER TRANSMISSION

Cable-operated clutch on the single, dry-plate type.

Floor-shift operated manual transmission has four synchromesh forward gears and one reverse.

Overdrive available on some models.

Optional automatic transmission.

Hypoid type final drive. Limited slip differential is optional.

## Clutch

Clutch release arm play approx.  $\frac{1}{8}$ " (3 mm)

Does not apply to cars with engine B23F or B21F Turbo.

## Transmission

Type designation	M 46	AW 55	AW 70
		BW 55	AW 71
Reduction ratios			
1st gear	4.03:1	2.45:1	2.45:1
2nd gear	2.16:1	1.45:1	1.45:1
3rd gear	1.37:1	1.00:1	1.00:1
4th gear	1.00:1	—	—
Overdrive	0.79:1	—	0.69:1
Reverse	3.68:1	2.21:1	2.21:1

## Rear axle

Reduction ratio	3.54:1	3.54:1	3.91:1
	3.73:1		3.73:1
	3.31:1		

## Speeds in mph (km/H) at 1000 engine rpm

Transmission—Manual	M 46	M 46	M 46
Rear axle ratio	3.31:1	3.54:1	3.73:1
1st gear	5.3 (8.5)	5.0 (8.0)	4.7 (7.5)
2nd gear	9.8 (15.8)	9.2 (14.8)	8.8 (14.1)
3rd gear	15.5 (25.0)	14.5 (23.4)	13.8 (22.4)
4th gear	21.3 (34.3)	19.9 (32.10)	18.9 (30.4)
Overdrive	26.9 (43.4)	25.2 (40.6)	23.9 (38.5)
Reverse	5.8 (9.3)	5.4 (8.7)	5.2 (8.3)

## Recommended max. and min. speeds, mph (km/h)

1st gear	2nd gear	3rd gear	4th gear
-25 (-40)	10-44 (20-70)	20-70 (30-110)	25-(44-)**

\*\* 35 mph (\*55 km/h) with overdrive engaged.

## Vehicle Loading

The tires on your Volvo will perform to specifications at all normal loads when inflated as recommended on the tire information label located on the rear facing side of the right front door. This label lists both tire and vehicle design limits.

Do not load your car beyond the load limits indicated.

See Consumer Information Booklet for complete tire pressure information.

## Tire Pressure Label

MAX LOAD	VEHICLE CAPACITY WEIGHT	OCCUPANTS		COLD TIRE PRESSURE		PSI	
	A	FRT	RR	TOTAL	FRONT		REAR
	A	2	3	5	36*	36	
RECOMMENDED FOR FUEL ECONOMY							
OPTIONAL PRESSURE							
TIRE SIZE	C	2 1 3		B		PSI	
* IF TIRES ARE NOT FROM SWEDEN AND 4PSI (28 kPa) TO THESE RECOMMENDED PRESSURES							
D		SPARE TIRE	INFLATION PRESSURE		E	PSI	
SEE OWNER'S MANUAL FOR ADDITIONAL INFORMATION							
<b>VOLVO</b>							
1338148							

56984

\* For DL, GL, GLE Canada: 35 35

## Tool kit

- Wheel nut wrench.
- 2 screwdrivers (1 Phillips, 1 standard)
- Tommy bar.
- 2 open end wrenches.

Car model	C Tire	A Vehicle capacity weight 2-d/4-d	B Optional pressure 1-3 occupants recommended pressure		D Special Spare	E Special Spare tire pressure	
			Front	Rear		Front	Rear
Sedan	DL	175R14	980/970	26	27	165-14	36 36
	GL	185/70R14	960	26	27	165-14	36 36
	Turbo	195/60R15	980/960s('1')	26	27	165-14	36 36
DL, GL, GLE (Can)	P185/75R14	960/940	26	28	165-14	36 36	
Wagon Turbo	DL, GL	185R14	1220	27	30	175-14	40 40
	DL, GL	195/60R15	970s('2')	27	27	175-14	40 40
	DL, GL (Can)	P185/75R14	1090	26	30	175-14	40 40

- 1) Canadian vehicles 960/940
- 2) Canadian vehicles 950

## Volvo Service Manuals

Service Manuals for your Volvo are available for purchase. These are the same used by competent Volvo technicians. Each major system in the car is covered by an individual Manual. These are grouped into ten sections and placed into a binder system. (Note that manuals and binders may be obtained separately or in preassembled sets.)

Major sections within the binder system include: 0-General Information; 1-Service and Maintenance; 2-Engine; 3-Electrical System and Instruments; 4-Power Transmission; 5-Brakes; 6-Suspension and Steering; 7-Frame, Springs, Dampers and Wheels; 8-Body; 9-Accessories and Other Equipment.

A Service Manual Brochure and Order Form was placed in the car prior to delivery from the dealer to you. Complete ordering information is provided.

Please note that these manuals may be offered for sale by your Volvo dealer. Prices charged by the dealer can vary from those listed in the brochure (according to Federal law).

Additional copies of the Brochure and Order Form may be obtained from your Volvo dealer, or by mail directly from:

Volvo of America Corporation  
Rockleigh Industrial Park  
Rockleigh, New Jersey 07647

Attention: Volvo Service Literature

**Note that the above pertains to vehicles sold in the U.S.A. only.**



Volvo supports Voluntary Mechanic Certification by the N.I.A.S.E. Certified mechanics have demonstrated a high degree of competence in specific areas.

Besides passing exams each mechanic must also have worked in the field for two or more years before a certificate is issued.

These professional mechanics are fully able to analyze vehicle problems and perform the necessary service procedures to keep your Volvo at peak operating condition.

**Note!** The above pertains to USA only.

Air conditioning	20	Dipstick	51	Hood lock	28
Air distribution	19	Door lock anti-freeze	81	Horn	4
Alternator, important note	65	Doors and locks	26	Ignition and steering wheel lock	8
Anti-freeze	64	Drain plug, engine	51	Instrument lights	9
Anti-rust treatment	77, 80	rear axle	62	Instruments and controls	4
Ash trays	16	transmission	60	Interior light	30, 70
Automatic transmission, driving	38	Drive belts	53	Jack	74
oil	61	Driving with trunk lid open	42	Keys	3
Battery	50, 91	Electrical system	91	Kick-down	39
Body and chassis	63	Emergency towing (pulling)	40	License plate lights	69
Brake fluid	50, 62	Engine	48, 89	Lighting	9
Brakes	43	Engine oil	50, 51	Limited slip differential	62
Break in period	34	Fan belts	53	Locks	26
Bulb failure warning light	7	Faul tracing	83	Long distance trips	81
Bulbs	66, 91	Federal Clean Air Act	45	Lubrication	63
Capacities	91	Front seats	22	Lumbar support	22
Carburetor	57	Front wheel alignment	92	Maintenance Service	45
Cargo space	88	Frozen locks	26, 81	Mirrors	29
Chassis number	87	Fuel	30, 50, 56	Odometer	6
Checking coolant	50, 64	Fuel gauge	6	Oil change, engine	51
oil	51	Fuel tank cap	30	rear axle	62
Child safety locks	27, 32	Fuses	71	transmission	60
Cigarette lighter	16	Gas filler cap	30	Oil filter	51
Clock	14	Gasoline	30, 44	Oil pressure	7, 15
Cold start	36	Gas station checks	50	Overdrive	37
Cold weather driving	81	Gear shift positions	37	Paint touch-up	78
Control lights	6	Hand brake	13	Parking brake	13
Coolant	64	Hazard warning flasher	12	Parking lights	9
Coolant, drain	53	Headlight flasher	8	Polishing	77
Cooling system	53, 64, 81, 90	Headlights	9, 66	Power steering	62
Defroster	18	replacement	66		95
Diagnosis	82	Heating	18		
Dimensions and weights	88				



# Index

---

Power train	92	Towing	40
Radios	21	Trailer hauling	42
Rear axle oil	62	Transmission oil	60
Rear seat, Wagon models	31	Trunk, 2 and 4-door models	27
Rear view mirrors	29	Turn signals	8
Rear window demister	12	Type designations	87
Rust protection	77	Upholstery, cleaning	77
Seat belts	24	Vehicle Identification Number	87
Seats	22	Ventilation louvers	18
Service diagnosis	82	VIN	87
Servicing	46	Warning lights	7
Shift positions	37	Warranty	45
Shop manuals, Volvo	94	Warranty inspection	34
Snow chains	73	Washer fluid	11, 81
Snow tires	73	Washer nozzles	10
Spare wheel	27, 33, 73	Washing	76
Spark plugs	90	Waxing	77
Specifications	88	Weights	88
Speedometer	6	Wheel alignment	92
Starting engine	36	Wheel change	74
Starting key	3	Wheels and tires	72
Steering wheel lock	8	Windshield washers	10, 81
Storage space, Wagon models	33	Windshield wipers	10
Sun roof	30	Wintertime driving	81
Tachometer	6		
Tailgate	32		
Tailgate window washer/wiper	10		
Temperature gauge	6		
Tire pressure	72, 93		
Tires	72		
Tire wear indicator	72		
Tools	93		
Touch-up	78		

## When filling gas always check:

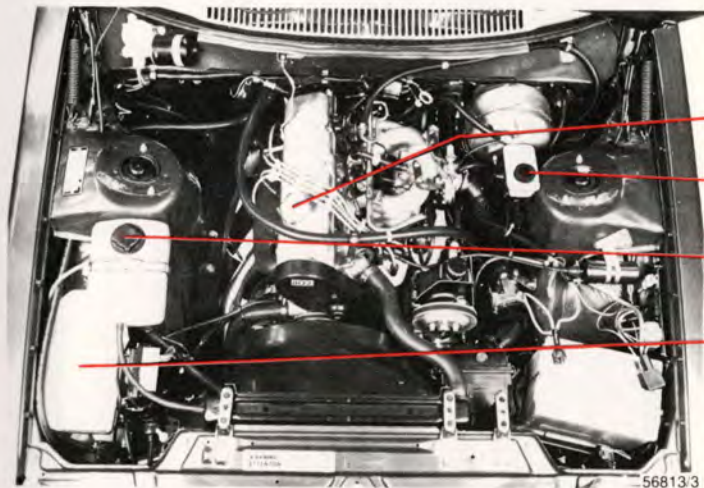

**Oil level** between dipstick marks. The distance between the marks represents approx. 1 US qt. = 1 liter. Fill multigrade oil.

Check without removing the cap that the **brake fluid** level is above the Min-mark. Brake and clutch fluid DOT 4.

**Coolant level** between the expansion tank marks. Mixture 50 percent anti-freeze and 50 percent water.

**Washer fluid** reservoir should be filled with water and solvent (wintertime: windshield washer anti-freeze).

**Electrolyte level**  $\frac{1}{4}$ "– $\frac{3}{8}$ " (5–10 mm) above plates. Fill distilled water only, never acid. Check level in conjunction with normal service or once a year.

### Fuel: Octane rating 91 Ron Unleaded, 87 (R + M)/2

B 21A engine for Canada requires 97 RON, 91(R + M)/2 leaded or 96 RON, 91 (R + M)/2 unleaded gasoline.

Unleaded fuel permitted for all other models and **required** for certain models (with catalytic converter).

#### **WARNING!**

Carbon monoxide is a poisonous colorless and odorless gas which is present in all exhaust gases. If you ever smell exhaust fumes inside the vehicle, make sure the passenger compartment is ventilated and immediately return the vehicle to dealer for correction.

**Never** sit in a parked or stopped car for any extended amount of time, nor have it unattended while engine is running.

**Never** operate engine in close unventilated areas.

---

# **VOLVO**

**VOLVO CAR CORPORATION**

**GÖTEBORG, SWEDEN**

TP 2410/2 (U.S.A., Canada)

**Printed in U.S.A**